

Owner's manual:
Jetta VS7
Stand: 29.01.2023
Englisch: 01.2023
Artikel-Nr.: 182.5C1.TRO.74





1825C1TRO74

Owner's manual

Jetta VS7

Jetta VS7 Owner's manual

Description of Symbols

 Refers to a section within a chapter that contains important information and safety notes .

 Indicates not the end of a section.

 Indicates the end of a section.

 Indicates situations in which the vehicle must be stopped as quickly as possible.

• The symbol indicates a registered mark. However, the absence of this symbol does not constitute a waiver of the rights concerning any term.

→  Symbols like these refer you to warnings within the same section or on a given page.

→  They draw your attention to possible risks of accident or injury and explain how they can be avoided.

→  Cross reference to potential risks of damage to property in the same section or on the page specified.

DANGER

Texts with this symbol indicate dangerous situations which will lead to fatal or severe injuries if you do not observe the warning.

WARNING

Texts with this symbol indicate dangerous situations which will lead to fatal or severe injuries if you do not observe the warning.

CAUTION

Texts with this symbol indicate dangerous situations which could lead to slight or medium injuries if you do not observe the warning.

NOTICE

Texts with this symbol indicate situations which could cause vehicle damage if you do not observe the warning.

 Texts with this symbol contain additional information on the protection of the environment.

 Texts with this symbol contain additional information.

FAW-Volkswagen works continuously to develop and further improve all vehicle types and models. Please understand that we must therefore reserve the right to alter any part of the vehicle and its equipment or technical specifications at any time. The data provided concerning scope of delivery, appearance, performance, dimensions, weights, fuel consumptions, standards and vehicle functions are all correct at the time of going to print (For details, please consult local FAW-Volkswagen dealerships).

No part of this manual may be reprinted, reproduced or translated without the written permission of FAW-Volkswagen.

All rights under the laws of copyright are expressly reserved by FAW-Volkswagen. Subject to alteration and amendment.

Printed in China

© January 2023 FAW-Volkswagen

Thank you for your trust in our company and our products!

With advanced technology, sophisticated technology and excellent performance, this car has excellent power, economy, comfort and safety, and is equipped with numerous convenience and entertainment functions for your use.

Before using this vehicle for the first time, please be sure to read this manual carefully, get familiar with the structure, functions, usage methods and relevant regulations of the company as soon as possible, use and maintain the vehicle correctly, make full use of the excellent performance of this vehicle, ensure safe driving and maintain the value of the vehicle.

All models of this car have passed the Chain Compulsory Certification (CCC certification). This manual is intended to provide users with instructions on the use and maintenance of the vehicle. Please check the purchase contract for the specific configuration of the vehicle you purchased. If you have any further questions about this car and the printed documents, please get in touch with Volkswagen dealership, they will always be happy to deal with your questions, suggestions or problems.

FAW-Volkswagen Automobile Co., Ltd. continuously to develop and further improve all vehicles. Please understand that the equipment and performance of subsequent models will be changed without prior notice. Please do not compare the contents of the instruction manual of other versions with the equipment and performance of the vehicle you purchased, and make requirements for supplementary equipment based on the differences between the two. If you are not sure about the vehicle and the instruction manual, please consult Volkswagen dealership. Please be sure to carry this instruction manual with you vehicle.

Faw-volkswagen Automobile Co. LTD

This instruction manual is applicable to the following models:

Vehicle model	Engine code	Gearbox type
FV6460LAACG	DJS	AG6
FV6460LAMCG	DJS	MG5
FV6460LAMEG	DLE	MG5
FV6460LAAEG	DLE	AG6



Table of Contents

Owner's manual writing instructions	4	Lights	
<hr/>		– Turn signals	72
Owner's manual		– Vehicle lighting	73
Vehicle overviews		– Headlight main beam	75
– Front view	5	– Parking light	75
– Side view	6	– Headlights	76
– Rear View	7	– Interior lighting	77
– Driver door overview	8	<hr/>	
– Driver side overview	9	Vision	
– Overview of Centre console	10	– Wipers	78
– Front passenger side overview	11	– Mirrors	80
– Controls in the roof	11	– Protection from the sun	83
<hr/>		<hr/>	
Driver information		Air conditioning system	
– Symbols in the instrument cluster	12	– Heating and air conditioning system	84
– Instrument cluster	13	<hr/>	
– Operating instrument cluster	23	Driving	
– Settings and display in the infotainment system	25	– Notes on driving	91
<hr/>		– Starting or switching off the engine	97
Safety precautions		– Start/stop system	101
– General notes	26	– Troubleshooting	103
– Correct sitting position	28	– Manual gearbox: Selecting a gear	103
– Seat belts	30	– Automatic gearbox	104
– Airbag system	37	– Steering	108
– Child seats	42	<hr/>	
– Operation Instructions in Emergency	49	Driver assist systems	
<hr/>		– General description	110
Switching on and off		– Cruise control system (GRA)	110
– Key kit	51	– Speed limiter	111
– Keyless lock/start systemKeyless Access (Keyless Access)	53	– Adaptive Cruise Control (ACC)	113
– Doors and central locking system	54	– Area monitoring system (Front Assist)	118
– Tailgate	58	<hr/>	
– Electric windows	60	Parking and manoeuvring	
– Electric panoramic sliding/tilting roof	62	– Parking	122
<hr/>		– Electronic parking brake	123
Steering wheel		– Information about the parking systems	126
– Adjusting the steering wheel position	64	– Park Distance Control	127
<hr/>		– Panoramic camera system (Area View)	129
Seats and head restraints		– Brake support systems	131
– Front seats	65	<hr/>	
– Rear seats	67	Practical equipment	
– Head restraints	69	– Stowage areas	133
– Seat functions	71	– Drink holders	136
		– Electrical sockets	137
		<hr/>	
		Data transfer	
		– Cyber security	141
		– Cable and wireless connections	141
		– App-Connect	143

<hr/>			
Transporting items			
– Stowing luggage and loads	144		
– Luggage compartment cover	145		
– Luggage compartment floor	145		
– Luggage compartment equipment	146		
– Roof carrier	146		
<hr/>			
Fuel and emission control			
– Safety information on using fuel	147		
– Fuel types and refuelling	147		
– Emission control	150		
<hr/>			
If and when			
– Vehicle toolkit	152		
– Wipers	153		
– Changing bulbs	155		
– Changing fuses	156		
– Jump starting	159		
– Towing	161		
<hr/>			
Checking and refilling			
– Engine compartment	165		
– Service fluids and consumables	169		
– Checking and refilling washer fluid	169		
– Engine oil	170		
– Coolant	174		
– Brake fluid	178		
– 12-volt vehicle battery	179		
<hr/>			
Wheels and tyres			
– Tyre monitoring system	183		
– Wheels and Tyres	186		
– Wheel covers	197		
– Changing a wheel	198		
<hr/>			
Vehicle care			
– Vehicle care	204		
– Accessories, modifications, repairs and renewal of parts	210		
<hr/>			
Customer information			
– Information recorded in the control units	213		
– Personal data protection	215		
– Event Data Recorder	217		
– Labels and plates	220		
– Communication window on the windscreen	220		
– Fluids in the air conditioning system	220		
– Radio reception and antenna	221		
– Electrical system component protection function	221		
– Declaration of conformity	221		
<hr/>			
		– Disposal of used batteries and electronic devices	222
		– Returning and scrapping end-of-life vehicles	222
<hr/>			
		Technical data	
		– Notes on technical data	223
		– Data plate and engine number letter	223
		– Vehicle identification number	224
		– Engine parameter	224
		– Vehicle dimensions	225
		– Vehicle performance parameter	225
		– Weights and axle loads	226
		– Seat position and backrest angle	227
		– Four-wheel alignment parameters	227
		– Brake system related data	228
		– Wheel and tyre related data	229
		– Tank capacities	229
		– Fuel consumption rate and CO ₂ emission	229
<hr/>			
		Abbreviations	231

Owner's manual writing instructions

- This instruction manual is for Jetta VS7 of all models and versions.
- A [glossary of acronyms](#) is attached at the end of this instruction manual, which is used to illustrate the meanings of abbreviations.
- Unless otherwise indicated, directions and positions of the vehicle such as front, rear, left and right in this instruction manual are normally relative to the vehicle's direction of travel.
- In this instruction manual, [illustrations](#) help with orientation and should be regarded as a general guide. The illustrations may differ from your vehicle.
- This instruction manual is only written for [left-hand drive vehicles](#). In right-hand drive vehicles the controls may differ from those displayed in illustrations or described in the texts.
- [Short definitions](#) in a contrasting colour that precede some sections provide a summary of the respective topic. More detailed information on system and equipment features, conditions, and system limits can be found in the relevant sections.
- Please refer to the supplementary instruction manual in the folder on the vehicle for any technical improvements made by the Company [after the publication of](#) this manual.

This manual describes all models of this vehicle and all equipment that may be equipped with it. It does not indicate whether it is optional equipment or standard equipment. Therefore, the vehicle you purchase may not have some of the equipment described in this manual, or it may be available only to vehicles sold in certain markets. Please check the purchase contract for the equipment configuration of your purchased vehicle. For details, please consult Volkswagen dealership.

All the technical data listed in the instruction manual apply to the situation when this manual is published. As our company constantly changes and improves the vehicles, the technical data of the vehicles you purchase may be different from the data listed in this manual. Please do not make legal claims against the Company based on the differences in the technical data, illustrations and instructions.

Please make sure that the printed documents are always in the vehicle. If you sell or lend the vehicle to someone else, be sure to give the printed documents to the new owner.

The following standard manuals should be included in the vehicle folder:

- Owner's manual
- Maintenance manual

Auxiliary manuals (optional equipment) that may be included in the vehicle folder:

- after the publication of
- Instructions for infotainment system
- After-sale Certificate
- Pre-sale inspection certificate
- *Other supplementary notes*



Vehicle overviews

Front view

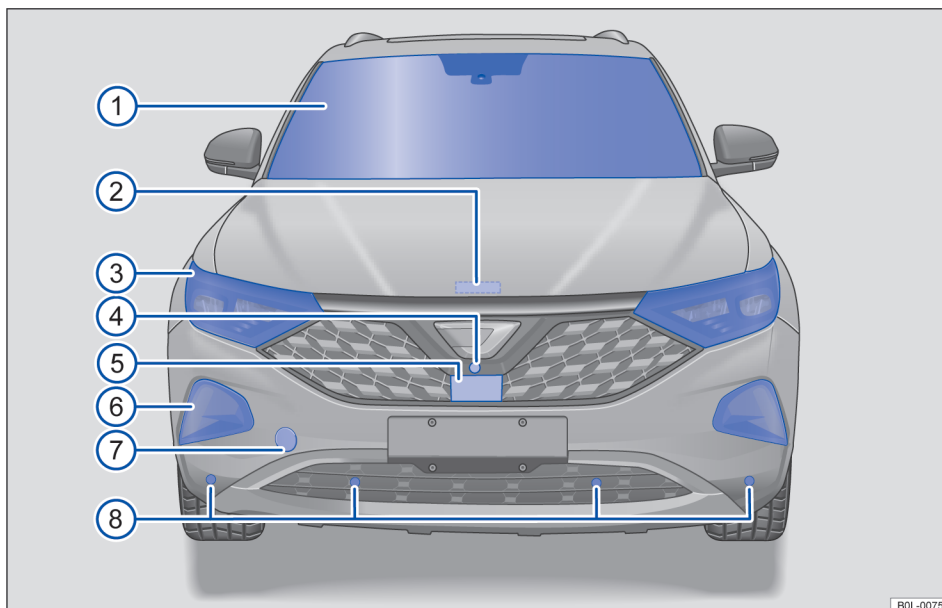
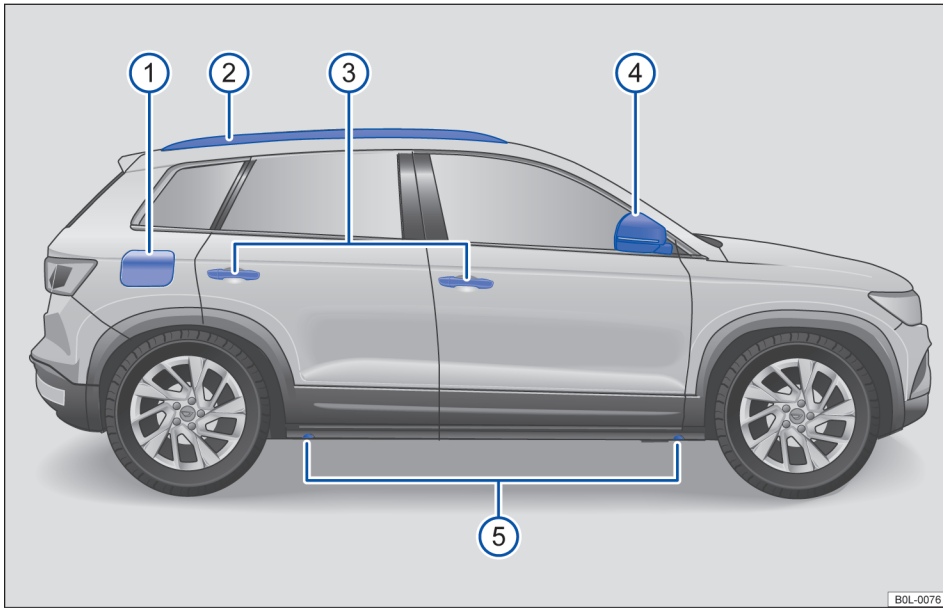

Fig. 1 Overview of vehicle from front

Fig. 1 Description:

① Windscreen:	
– with vehicle identification number.....	223
– with windscreen wiper.....	78, 153
– with rain/light sensor positioned near the interior mirror.....	79, 206
– Car light function sensor.....	74, 206
② Release lever for bonnet.....	165
③ Headlights.....	72
④ Area View camera.....	129
⑤ Sensors for assist systems.....	206
⑥ Daytime running light.....	72, 155
⑦ Behind a cover: mounting for front towing eye.....	161
⑧ Radar sensors for parking system.....	206 ◀

Side view



BOL-0076

Fig. 2 Overview of vehicle from right

Fig. 2 Description:

① Tank flap.....	147
② Roof railing.....	206
③ Door release lever.....	54
④ Exterior mirrors.....	82
– Auxiliary turn signals.....	72
– Ambient lighting (depending on vehicle type).....	
– Area View camera.....	129
⑤ Jacking points.....	198 ◀

Rear View

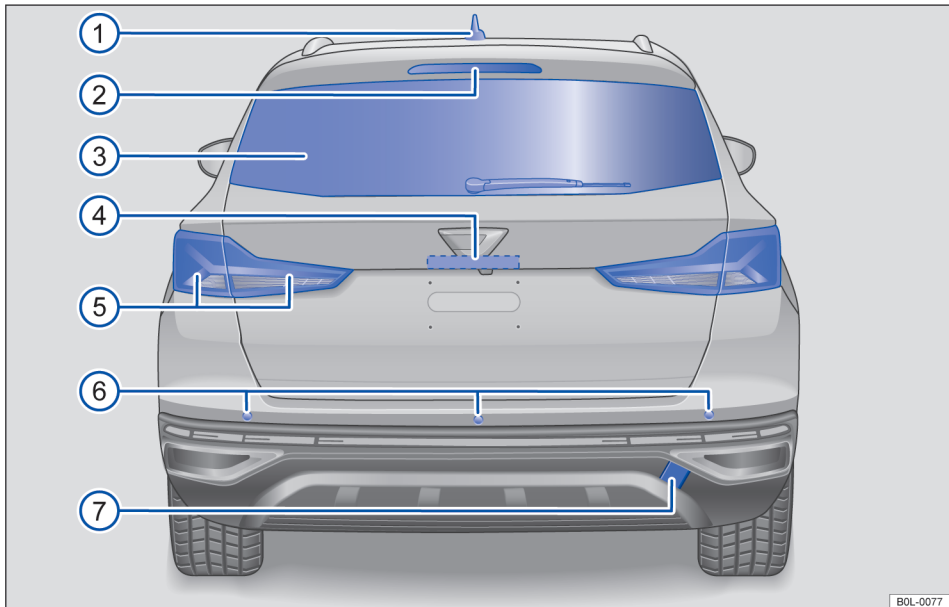

Fig. 3 Overview of vehicle from rear.

Fig. 3 Description:

①	Roof aerial.....	213
②	High-level brake light	
③	Rear window:	
	– with rear window heating.....	84
	– with rear window aerial	
	– with rear window wiper	78, 153
④	Button for opening the boot lid:	
	– with camera for rear view system.....	110
	– License plate lamp.....	155
⑤	Tail light clusters.....	72, 155
⑥	Radar sensors for parking system.....	206
⑦	Behind a cover: mounting for rear towing eye.....	161 ◀

Driver door overview

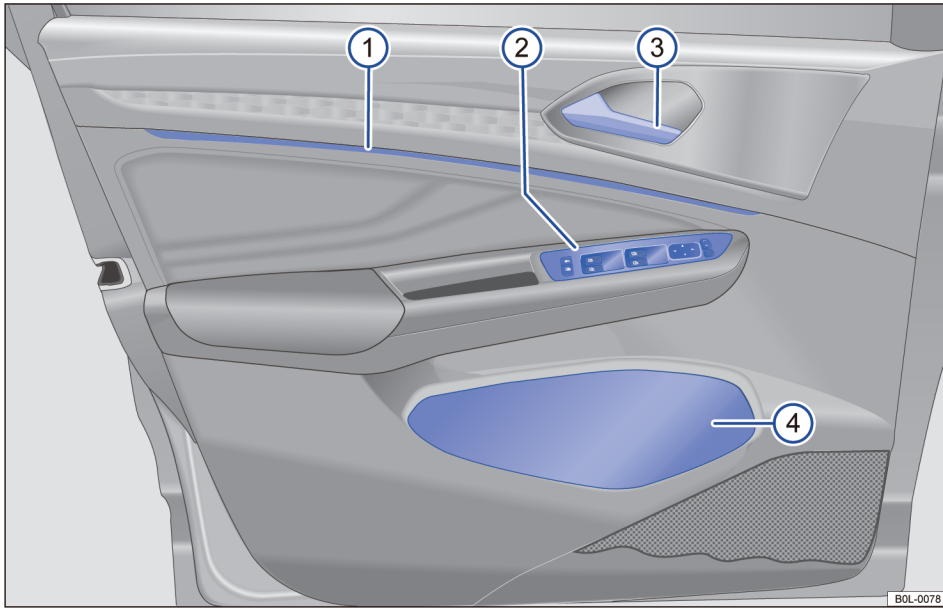

Fig. 4 Overview of driver door operating mechanism

Fig. 4 Description:

①	Door background lighting (depending on vehicle equipment)	
②	Operating mechanism area:	
	– Rotary knob for exterior mirror settings and functions.....	82
	– Buttons for operating electric windows.....	55
	– Central locking button for locking and unlocking vehicle.....	54
③	Door release lever.....	54
④	Stowage compartment or stowage compartment for high-visibility waistcoat.....	133 <

Driver side overview

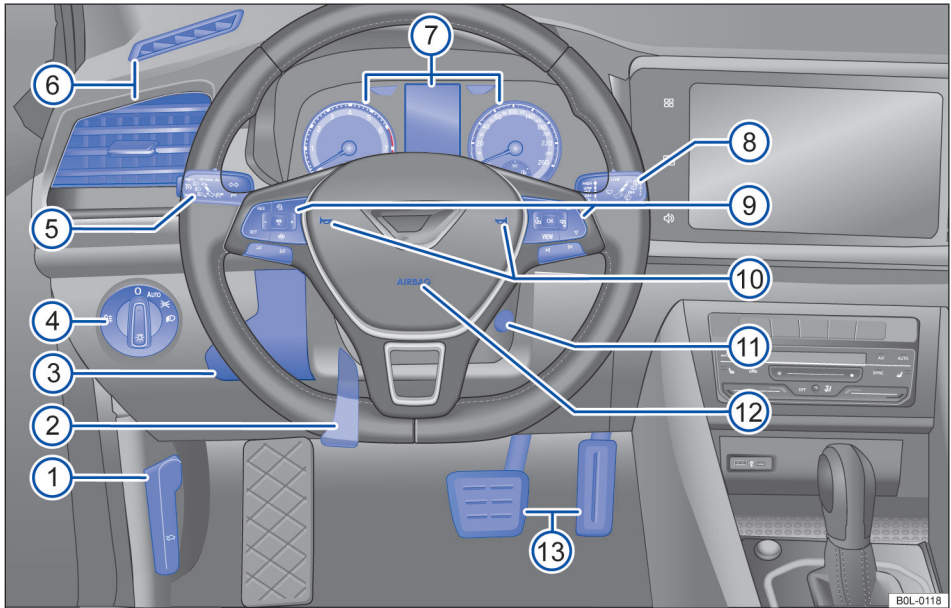





Fig. 5 Overview of the driver side

Fig. 5 Description:

① Release lever for bonnet	165
② Steering column adjusting lever	64
③ Fuse box cover plate	156
④ Light switch	73
⑤ Turn signals and headlight main beam lever	73
– With switches and buttons for driver assist systems	110
⑥ Vents	84
⑦ Instrument cluster	13
– With alarm/indicator lamp	12
⑧ Lever for wipers and washers	78
⑨ Controls on the multifunction steering wheel:	
– with buttons for menu selection	13
– for driver assist system (depending on vehicle type)	24, 110
– for audio 	
– for volume adjustment 	
– for activating voice control  (depending on vehicle equipment)	
⑩ Horn	
⑪ Ignition switch	97
⑫ Driver's front airbag	37
⑬ Pedals	91

Overview of Centre console

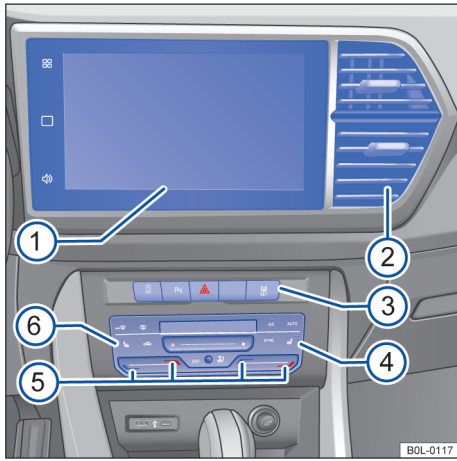

Fig. 6 Overview of the upper section of the centre console

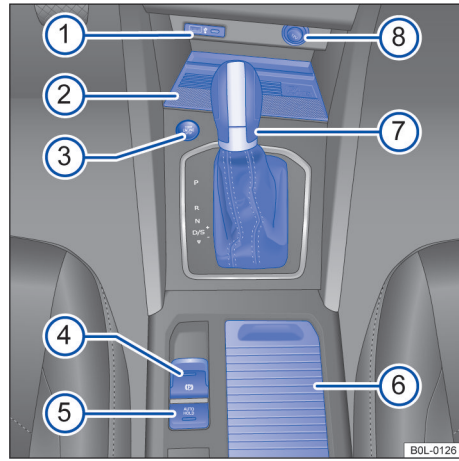

Fig. 7 Overview of the lower section of the centre console

Fig. 6 Description:



① Infotainment system→ Booklet <i>Infotainment system</i>	
② Vents.....	84
③ Control buttons:	
– for hazard warning lights 	49
– for assist systems for parking and manoeuvring.....	110
– for start/stop system.....	101
– Tyre pressure monitoring system.....	183
④ Right front seat heating button.....	89
⑤ Controls for air conditioning system.....	84
⑥ Left front seat heating button.....	89

Fig. 7 Description:

① Multimedia interface→ Booklet <i>Infotainment system</i>	
② Stowage compartment:	
– With function for wireless charging in accordance with Qi standard.....	140
③ Start/stop button.....	98
④ Electronic parking brake.....	123
⑤ Auto Hold system AUTO HOLD	125
⑥ Stowage compartment with drink holder.....	133
⑦ Lever:	
– Automatic gearbox.....	104
– Manual gearbox.....	103
⑧ 12V power socket (depending on vehicle equipment).....	137 

Front passenger side overview

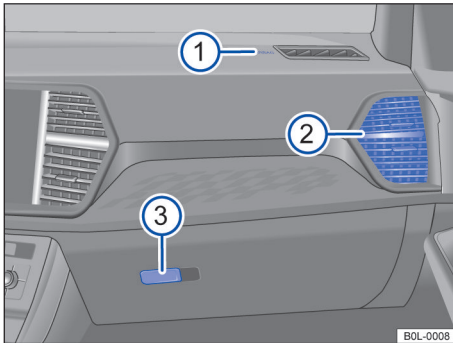

Fig. 8 Overview of front passenger side

Fig. 8 Description:

①	Location of front passenger front airbag in dash panel.....	37
②	Vents.....	84
③	Opening lever of the storage compartment.....	133

Controls in the roof

Symbol	Meaning
	Interior light and reading light buttons → page 77
	Switch for glass roof → page 62
	Buttons for the sun blind → page 83

Driver information

Symbols in the instrument cluster

The alarm/indicator lamp can be lit individually or in combination to indicate a variety of different alarms, failures, or certain functions. Some alarms/indicators will light up when the ignition is switched on and should be turned off once the engine is running or the vehicle is in motion.













Depending on the vehicle configuration, the instrument cluster may display symbols rather than alarm lights.

Some warning lights and indicators are not applicable on all models, depending on the vehicle configuration.

For details on indicator lamps that light up in the light switch, see Chapter "Lights".→ page 72

Symbol	Meaning
	Central warning lamp: The auxiliary information displayed on the instrument cluster must be strictly adhered to.
	Electronic parking brake→ page 123.
	The braking system is faulty → page 96 or Low brake fluid level→ page 178.
	The electro-mechanical steering system has failed→ page 109.
	Driver or front passenger not wearing seat belt→ page 31.
	Autonomous Emergency Braking (Front Assist) warning→ page 119.
	Be prepared to brake→ page 113.
	Coolant→ page 22.
	Engine oil pressure→ page 174.
	Fault in the 12-volt power supply system→ page 182.
	Central warning lamp: The auxiliary information displayed on the instrument cluster must be strictly adhered to.

Symbol	Meaning
	Electronic Stability Control (ESC) or Acceleration Slip Regulation (ASR)→ page 132.
	Acceleration Slip Regulation (ASR) switched off.→ page 132
	Anti-lock braking system (ABS) is faulty→ page 132.
	Rear fog lights are on→ page 74.
	Particulate filter clogged with soot → page 150.
	The exhaust system is faulty→ page 151.
	The engine management system has failed→ page 101.
	Fault in electro-mechanical steering system→ page 109.
	Tyre pressure monitoring system → page 185.
	Fuel tank almost empty → page 21.
	Fault in airbag and seat belt tensioner→ page 38.
	Turn signals→ page 72.
	Be prepared to brake.
	Auto Hold function→ page 125.
	General Rate Application (GRA)→ page 110 or Adaptive cruise control→ page 116or Speed limiter→ page 111.
	Headlight main beam or headlight flasher→ page 75.
	Adaptive Cruise Control (ACC) is unavailable→ page 117.
	Autonomous Emergency Braking (Front Assist) switched off→ page 121.
	Autonomous Emergency Braking (Front Assist) switched off→ page 121.
	The vehicle running light is faulty→ page 74.
	Fault in the 12-volt power supply system→ page 182.
	General Rate Application (GRA)→ page 110. ▶

Symbol	Meaning
	The ACC is regulating, no vehicle detected in front→ page 116.
	The ACC is regulating, vehicle in front detected→ page 116.
	Autonomous Emergency Braking (Front Assist) is starting up.→ page 118.
	Distance warning of Autonomous Emergency Braking (Front Assist)→ page 119.
	General Rate Application (GRA) is faulty→ page 110.
	The speed limit is activated→ page 111.
	Service due→ page 22.
	The ambient temperature is lower than +4 ° C→ page 15.
	Start/stop system active→ page 101.
	Start/stop system is unavailable→ page 101.
	Starting the engine.
	Reference to information in the printed documents.

WARNING

Be sure to pay attention to the lighted alarm/indicator lamp and the text message displayed, otherwise you could easily break down and cause an accident which could seriously injure someone.

- Never ignore alarm lights or text messages!
- Stop as soon as possible and be safe when operating

Instrument cluster

Introduction

This chapter contains information on the following subjects:

- Analogue instrument cluster 14
- Rev counter 14

- Digital instrument cluster (basic) 15
- Displays 15
- Service menu 16
- Driving data (Multifunction display) 17
- Driving data display (multifunction display) 18
- Warning and information messages 19
- Driver Alert System (Recommendation for rest breaks) 19
- Time 20
- Fuel gauge 21
- Coolant temperature display 22
- Service interval display 22

Depending on the model equipment, the vehicle may be equipped with a analogue or a digital instrument cluster.

After starting the engine, some system Settings (such as the time, date, personal convenience settings, and programming) may be changed or deleted when the battery power of the 12-volt vehicle battery is too low or the battery is replaced. After the battery is fully charged, check and update system settings again.

WARNING

Do not distract your attention while driving, otherwise it is easy to cause accidents and injuries!

- Do not operate the buttons on the instrument cluster while the vehicle is moving.
- All the settings of the instrument cluster and infotainment system screen display can be performed only when the vehicle is stationary to reduce the risk of accidents and injuries.

WARNING

If there is a serious fault in the instrument cluster, the display may switch off. The indicator light  might additionally light up.

- Stop the vehicle safely.
- Seek help from Volkswagen dealership professionals.

Analogue instrument cluster

📖 Please refer to ⚠️ at the start of the chapter on page 13.

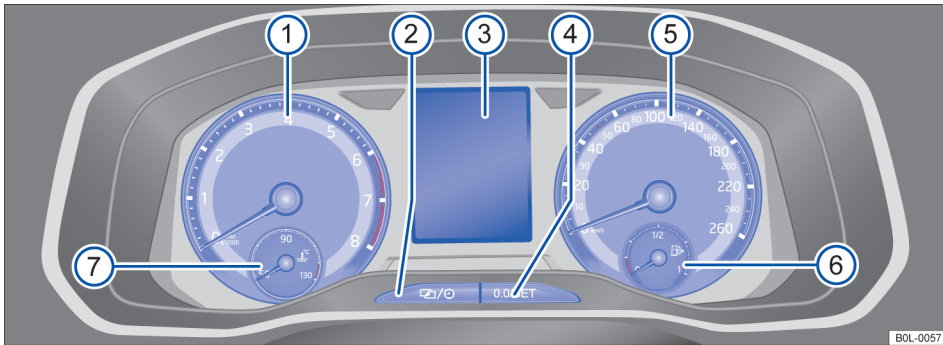

Fig. 9 Analogue instrument cluster in the dash panel

Instrument illustration:→ Fig. 9

- ① **Rev counter** (running engine speed in revolutions x 1,000 per minute)→ page 14
- ② **Menu button**
- ③ **Display screen**→ page 15
- ④ **Reset to zero/adjust button.**
- ⑤ **Speedometer**
- ⑥ **Fuel gauge**→ page 21
- ⑦ **Engine coolant temperature gauge**→ page 22

Rev counter

📖 Please refer to ⚠️ at the start of the chapter on page 13.

Rev counter

The starting point of the red area on the dial indicates the maximum allowable engine speed at each speed stop. Only when the engine is properly run in and reaches the normal operating temperature can it run at the maximum allowable speed for a short time. Before the pointer reaches the red area, it should be changed into the near high gear or the selector lever should be moved into gear **D/S**, or release the gas pedal→ ⚠️.

⚠️ NOTICE

- When the engine is in a cold state, it is necessary to avoid excessive engine speed, full throttle and large engine load.
- The pointer of the Rev counter can only be in the red area of the dial for a short time, otherwise, the engine may be damaged.

🌿 Timely switching to near high gear helps to save fuel and reduce engine noise. <

Digital instrument cluster (basic)

📖 Please refer to ⚠ at the start of the chapter on page 13.

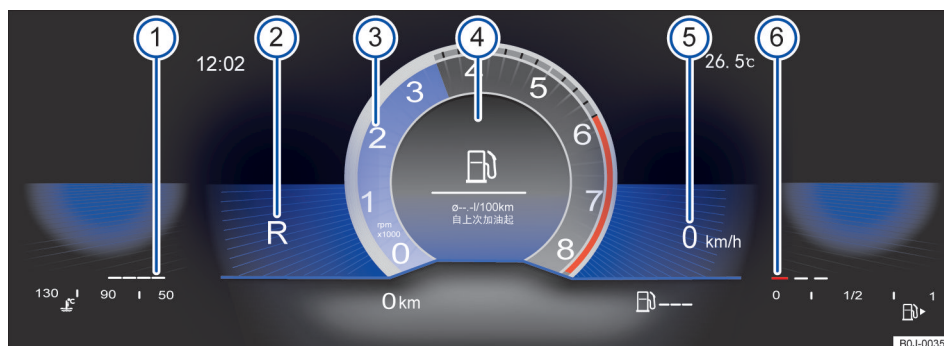

Fig. 10 Digital instrument cluster in the dash panel

Explanation about the meter → Fig. 10:

- ① **Engine coolant temperature gauge** → page 22
- ② **Selector lever position** (depending on the model equipment) → page 104

- ③ **Rev counter** (running engine speed in revolutions x 1,000 per minute) → page 14
- ④ **Display screen** → page 15
- ⑤ **Digital speedometer**
- ⑥ **Fuel gauge** → page 21

Displays

📖 Please refer to ⚠ at the start of the chapter on page 13.

Possible displays on instrument cluster

The type of information displayed on the instrument cluster depends on the vehicle configuration:

- Doors, bonnet and boot lid open
- Alerts and text messages
- Driving distance
- Travel time → page 20
- Ambient temperature
- Selector lever position display
- Shift cue → page 91
- Driving data display (Multifunction display (MFD)) → page 24
- Maintenance cycle display → page 22
- Speed limit warning → page 24

- Automatic engine start-stop system status display → page 101
- The driver assistance system shows → page 110

Open doors, bonnet and boot lid

When the vehicle is unlocked or in motion, the instrument cluster indicates whether the door or engine hatch or tailgate is open. In some cases, the system will also play a prompt tone. The display items may be different for different types of instrument cluster.

Selector lever position (automatic gearbox)

The selected selector lever position is displayed next to the selector lever and on the instrument cluster. If the selector lever is in gear **D/S**, or when you are in Tiptronic manual shift mode, the screen displays the current speed shift → page 104.

Outside temperature display

Depending on the vehicle and equipment, if the ambient temperature falls below +4°C, the temperature display will show a snowflake symbol ▶

❄️(thin ice alert) in addition to the display temperature. This symbol is displayed until the ambient temperature rises above +6°C → ⚠️.

When the vehicle is at rest or travelling at a lower speed, the temperature displayed may be slightly higher than the actual ambient temperature due to the thermal radiation effect of the engine.

Temperature measurement ranges from -45°C to +76°C.

Gear-change indicator

To reduce fuel consumption, the display may suggest a fuel-saving gear while the vehicle is in motion → page 91.

Mileage displays

Total odometer record the total miles travelled by the vehicle.

One-way odometer (trip) indicates the distance travelled since the last one-way mileage recorder reset.

- *Models equipped with analogue instrument cluster:*
One-way odometer can be reset by pressing **[0.0/SET]** on the instrument cluster → page 14.

Automatic engine start-stop system status display

The instrument cluster displays the current status information of the automatic engine start-stop system → page 101.

Engine code

Depending on the vehicle type, some types of instrument cluster can display the engine code.

Models equipped with digital instrument cluster (basic):

- In the instrument cluster menu, open the submenu **Mileage/Time**, select menu item **Reset "from the start "** or **Reset "the accumulation"**;
- Press and hold the button **[⏏]** or **[⏏]** on the multifunction steering wheel about 5 seconds to bring up the service menu → page 16;
- Select the **Engine Code** menu item.

⚠️ WARNING

Streets and Bridges can freeze when ambient temperatures are around zero.

- "Snowflake" symbol indicates the danger of thin ice.

- In ambient temperatures above +4 °C, roads may freeze even if the display does not display the snowflake symbol that indicates a thin ice warning.
- Do not rely only on the ambient temperature display screen to determine whether the road is icy!

i We have different models of instrument cluster, so the type and display items of instrument cluster may be different. If the instrument cluster has no alarm or message text display function, only the alarm/indicator lamp is used to indicate vehicle failure.

i If the system detects several faults, each fault alert symbol is displayed for a few seconds in turn. The fault symbol is displayed until the fault is removed.

i If the display displays fault alarm information when the ignition switch is on, some settings cannot be performed according to the preceding methods, or the display may display error information. In this case, you should drive to the qualified workshop as soon as possible to troubleshoot the problem. ◀

Service menu

Only applicable to models equipped with digital instrument cluster (basic)

📖 Please refer to ⚠️ at the start of the chapter on page 13.

Depending on the vehicle, the information can be set in the service menu through the multifunction steering wheel.

Bring up the service menu

To bring up the Service menu, in the instrument cluster menu, open the submenu **Mileage/Time**, select menu item **Reset "from the start "** Or **Reset "the accumulation"**, then press and hold the button **[⏏]** or **[⏏]** on the multifunction steering wheel for 5 seconds, you can use the button on the multifunction steering wheel to navigate the menu in the normal way.

Maintenance

Select the **Maintenance** menu and display the maintenance information on the instrument cluster. ▶

Reset the oil change maintenance data

Select the **Reset Oil Change Maintenance data** menu and confirm by pressing the button **OK** on the multifunction steering wheel.

Reset vehicle condition check data

Select the **Reset Vehicle Condition Check data** menu and confirm by pressing the button **OK** on the multifunction steering wheel.

Engine code (MKB)

Depending on the vehicle, select menu **Engine code**. Engine code can be displayed on the instrument cluster.

Set time



Select the **Time** menu and set the correct time by pressing the button **OK** on the multifunction steering wheel.

Copyright information

Depending on the vehicle type equipment, select the menu **Copyright information**, the copyright information can be displayed on the instrument cluster.

Driving data (Multifunction display)

Only applicable to models equipped with analogue instrument cluster

 Please refer to  at the start of the chapter on page 13.

Driving data (multifunction display) display a variety of vehicle driving data and fuel consumption data.

Depending on the vehicle, it may show different driving data. The driving data shown depends on the current driving behavior, vehicle condition (e.g. particle catcher regeneration), and driving condition (e.g. city or highway driving). The driving data is determined by the average of different lengths of road, which means that the current displayed value may differ from the actual average.

Toggle display item

Press the button **△** or **▽** → page 24 in the multifunction steering wheel.

Switch drive data storage

Press the button **OK** in the multifunction steering wheel.

Memory from the start

If the interrupted driving time is more than two hours, the system automatically deletes the data in the memory.

Memory since refuelling

Display and store collected driving and fuel consumption data. The system automatically deletes the data in the memory when fuel is added.

Memory accumulation

The memory collects travel data for any number of one-way trips. Depending on the instrument cluster type, the driving time collected by the memory can be up to 19 hours 59 minutes or 99 hours 59 minutes, and the driving range can be up to 9,999.9km. If the driving time or mileage exceeds any of the three maximum values¹⁾, the system automatically deletes the driving data from the memory.

Manually clear the drive data memory

- Select the storage you want to delete.
- Press and hold the button **OK** in the multifunction steering wheel for about 2 seconds.

Current fuel consumption

Speed higher than 5 km/h, display the **fuel consumption of 100Km (L/100Km)**; Speed below 3Km/h, display **fuel consumption per hour (L/h)**.

Average consumption

The average fuel consumption is displayed on the screen after the starting driving of about 300m.

Driving range

Approximate mileage of remaining fuel at current driving conditions.

Travel time

The elapsed time after turning on the ignition is shown in hours (h) and minutes (min).

Driving distance

Displays the distance travelled (km) after turning on the ignition switch. 

¹⁾ Depending on the instrument cluster model

Average speed

The average speed will be displayed on the screen after the starting drive of about 100 meters.

Digital speed

The current travelling speed (Km/h) is displayed in digital form.



Sets the overspeed alarm

- Select display -- km/h speed alarm .
- Press the button **OK** in the multifunction steering wheel to store the current speed as the alarm speed in the system and activate the warning.
- If necessary, the speed can be adjusted in about five seconds with the buttons **▲** or **▼** in the multifunction steering wheel. Then press the button **OK**, or wait a few seconds, to store the speed and activate the alarm.
- If you need to switch off the speed alarm, press the button **OK** again to delete the stored speed.

Warnings can be set in the travel speed range from 30 km/h to 250 km/h.

Driving data display (multifunction display)

Only applicable to models equipped with digital instrument cluster (basic)

 Please refer to  at the start of the chapter on page 13.

Driving data (multifunction display) display a variety of vehicle driving data and fuel consumption data.

Depending on the vehicle, it may show different driving data. The driving data shown depends on the current driving behavior, vehicle condition (e.g. particle catcher regeneration), and driving condition (e.g. city or highway driving). The driving data is determined by the average of different lengths of road, which means that the current displayed value may differ from the actual average.

Select the driving data display item

- Depending on the information mode selected, this can be done by buttons **☰** or **☲** to open the selection menu, then by buttons **▲** or **▼** to select the Driving data. Or directly through the buttons **▲** or **▼** to open the selection menu and select Driving data.→ page 24

Select drive data memory

- Select the required driving data (such as average consumption, miles/time travelled, and average speed).
- Press the buttons **☰** or **☲** in the multifunction steering wheel to open the corresponding menu item.
- Select the drive data memory via buttons **▲** or **▼** in the multifunction steering wheel.
- Press the button **OK** in the multifunction steering wheel to confirm, and the selected drive data memory will be displayed in the instrument cluster.

Memory from the start

If the interrupted driving time is more than two hours, the system automatically deletes the data in the memory. 

Memory since the last refuelling

Display and store collected driving and fuel consumption data. The system automatically deletes the data in the memory when fuel is added.



Memory accumulation

The memory collects travel data for any number of one-way trips. Depending on the instrument cluster type, the driving time collected by the memory can be up to 19 hours 59 minutes or 99 hours 59 minutes, and the driving range can be up to 9,999.9km. If the driving time or mileage exceeds any of the three maximum values¹⁾, the system automatically deletes the driving data from the memory.

Clear the drive data memory

- Select the required driving data (such as average consumption, miles/time travelled, and average speed)→ page 18.
- Press the buttons **☰** or **☲** in the multifunction steering wheel to open the corresponding menu item. 

¹⁾ Depending on the instrument cluster model

- Select the drive data memory to be emptied through buttons  or  in the multifunction steering wheel.
- Press the button  in the multifunction steering wheel to confirm clearing.

Current consumption display

The current consumption is displayed digitally.



Average consumption display

The average fuel consumption is displayed on the screen after the starting driving of about 300m.

Average speed display



The average speed will be displayed on the screen after the starting drive of about 100 meters.

Warning and information messages

 Please refer to  at the start of the chapter on page 13.

The system checks certain components and functions when the ignition switch is on or when the vehicle is running. The instrument cluster indicates vehicle failure by displaying red and yellow alarm symbols accompanied by text messages → page 12 and, in some cases, a beep. The display items may be different for different types of instrument clusters.

Depending on the vehicle type equipment, you can also manually call up the current list of faults to be dealt with. Select the **Vehicle Status** menu item to display the fault list → page 24.

Level 1 alarm Alarm light shining or lit red, or central warning light  Shine or light red- Sometimes a prompt tone is played simultaneously.  **Do not drive on!** The vehicle is in a dangerous condition. Check the fault and troubleshoot the cause. If necessary, ask professional help to solve the problem.

Level 2 alarm Alarm light shining or lit yellow, or central warning light  Shine or light yellow- Sometimes a prompt tone is played simultaneously. If there is a functional failure or insufficient storage of vehicle oil, it may damage the vehicle or cause it to break down. Check the fault as soon as possible. If necessary, ask professional help to solve the problem.

Warning to pay attention to the owner's manual information

 Symbol lighting- You can find more information about the current warning in the owner's manual.

Text information Information about how vehicle-related processes are handled.



If the system detects several faults, each fault alert symbol is displayed for a few seconds in turn. The fault symbol is displayed until the fault is removed.



If the display displays fault alarm information when the ignition switch is turned on, some settings cannot be performed according to the preceding methods, or the display may display different information. Please drive to the qualified workshop as soon as possible to troubleshoot the problem.

Driver Alert System (Recommendation for rest breaks)

 Please refer to  at the start of the chapter on page 13.



Fig. 11 instrument cluster: fatigue warning symbol

The driver fatigue warning system identifies whether the driver is in a state of fatigue according to the driving state of the vehicle. If the driver is in a state of fatigue, the system will immediately warn the driver.

Working principle and operation methods

After the vehicle starts running, the fatigue recognition system starts to judge the driving state of the driver and evaluate the fatigue degree of the driver. The system continuously compares the fatigue level of the driver with the actual driving state of the vehicle. If the system finds

that the driver is in a state of fatigue, it will issue an alarm and display the corresponding information on the instrument cluster screen → Fig. 11 to warn the driver to pay attention. The instrument cluster displays the corresponding information for about 5 seconds, and may display it again if necessary. The system stores the last displayed information.

Press the button  on the multifunction steering wheel to switch off the information displayed on the instrument cluster → page 23. The information can be redisplayed through multifunction display → page 19.

Working condition

Only when the vehicle speed is 65 km/h to 200 km/h can the system evaluate the fatigue degree of the driver through the running state of the vehicle.

System limitations

The driver fatigue warning system has certain system limitations. Therefore, the system may not be able to correctly identify the driver's driving condition when the following driving conditions occur:

- When vehicle speed is below 65 km/h,
- Speed higher than 200 km/h,
- When driving along a road with many curves
- While driving on a construction site
- When driving on bad roads
- In bad weather
- When driving a vehicle in a sports style
- When the driver is distracted

The fatigue warning system will be reset if:

- Switch off ignition switch
- The driver unbuckled the seat belt and opened the driver's side door
- The vehicle stays in place for more than 15 minutes

When the vehicle travels at a low speed for a long time (below 65 km/h), the driver fatigue warning system automatically reset. If the speed is increased, the system will reassess the driver's driving condition when the speed is higher than the above speed.

⚠ WARNING

Do not take advantage of the extra convenience provided by the driver fatigue warning system to risk driving - beware of causing accidents! Regular breaks should be taken during long journeys, and the rest periods should be long enough.

- Drivers should always ensure that they are physically fit to drive.
- Never drive a vehicle under fatigue.
- The system is not always able to detect driver fatigue in all circumstances. Please read the instructions in the "System Limitations" section of this manual carefully.
- In rare cases, the system may misinterpret appropriate driving actions as indicating that the driver is fatigued.
- The system does not issue emergency alerts for "drowsy" drivers!
- Be sure to observe the relevant information displayed on the instrument cluster and operate the vehicle as required.





 The driver fatigue warning system only applies to driving on highways and good hard surfaces.

 If the system is faulty, you should check the system at the qualified workshop as soon as possible. ◀

Time

 Please refer to  at the start of the chapter on page 13.

Models equipped with analogue instrument cluster

- Press the button  on the instrument cluster until the display displays the text **Time** → page 14.
- Release the button . The display displays the current time and enters the hour setting mode.
- Press the button  repeatedly until the desired number of hours is displayed. Hold down the button  to quickly adjust the hour value.
- After setting the hour value, press the button  to enter the minute setting mode. ▶

- Press the button **0.0 / SET** repeatedly until the minutes required are displayed. Press and hold the button **0.0 / SET** to quickly adjust the minutes.
- Release the button **0.0 / SET** or press the button **⏸/⏹** to end clock setting.

A vehicle equipped with a digital instrument cluster (basic)

- Call out **the Service Menu** → page 16.
- Select the **Time Menu**.
- Use the button **OK** to set the correct time.

Fuel gauge

📖 Please refer to ⚠ at the start of the chapter on page 13.

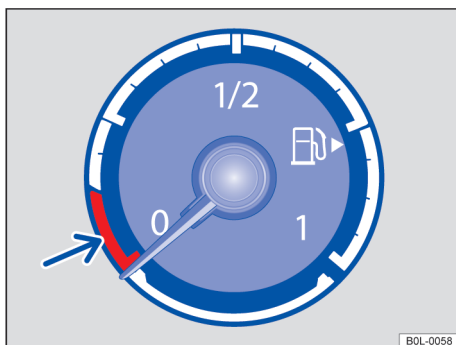

Fig. 12 Fuel gauge in the analogue instrument cluster



Fig. 13 Fuel gauge in the digital instrument cluster

The fuel tank is running out of fuel.

The yellow alarm light is on. The vehicle runs on spare fuel (arrow pointing area) → ⚠.

- Add fuel as soon as possible.

Fuel filler cover is not closed correctly

Depending on the vehicle, the instrument cluster may display a text message to **check the tank flap**.

- Stop safely and switch off the engine and ignition as soon as possible;
- Open the tank flap and unscrew the fuel filler cover.
- Turn the refuelling port cover clockwise into the refuelling port again, and hear its stuck sound.
- Close the tank flap.

After re-opening the ignition switch, the text message may still be displayed on the instrument cluster even if the refuelling port cover is correctly closed. This is a normal phenomenon and there is no need to worry about it. After the system completes the oil tank tightness test again and confirms that it is good, the text information will disappear automatically.

If the instrument cluster displays both the text message and the alarm light ⚠, drive to the nearest qualified workshop of the company to check the engine and fuel system as soon as possible.

WARNING

The fuel level in the fuel tank is too low, which may cause the vehicle to break down suddenly on the way, resulting in serious casualties!



- Too low fuel level may lead to irregular fuel supply of the engine fuel system, and the vehicle is easy to stall when driving downhill on the mountain road.
- If the engine may run unsmoothly or stall completely due to insufficient or irregular fuel supply, the steering system, all intelligent driving assistance systems and brake assistance systems will not work.
- Fuel should be added when 1/4 of the fuel is left in the fuel tank to avoid the vehicle running until there is no fuel in the fuel tank and breaking down.

NOTICE

Do not run until the fuel tank is completely depleted! Irregular fuel supply may lead to engine fire or tempering, unburned fuel into the exhaust system, damage the catalytic converter!

 The small arrow next to the fuel filler symbol in the fuel gauge indicates the orientation of the fuel tank cover plate on the vehicle.

Coolant temperature display

 Please refer to  at the start of the chapter on page 13.

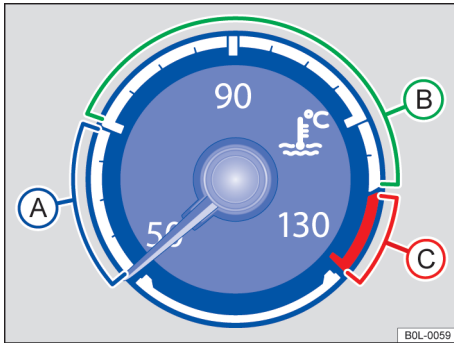

Fig. 14 Engine coolant temperature display in analogue instrument cluster

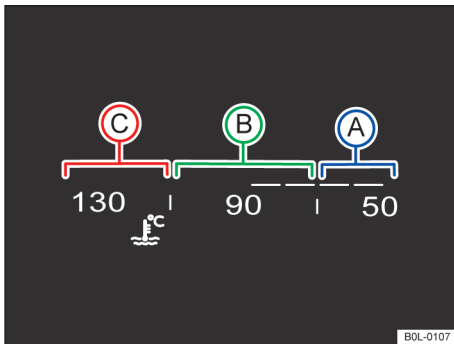

Fig. 15 Coolant temperature display in digital instrument cluster

- A** Low temperature zone. The engine has not yet reached operating temperature. Avoid heavy engine load and high speed operation until the engine reaches the operating temperature.
- B** Normal temperature zone.
- C** Alarm temperature zone. The pointer may also point to the warning area when the engine load is high (especially when the ambient temperature is high).

Engine coolant

The alarm light is on and the central alarm light is flashing red.

Coolant level is abnormal or the engine coolant system is faulty.

Do not drive on!

- Stop immediately, switch off the engine and allow to cool completely.
- Check the coolant level → page 174.
- If the engine coolant level is normal, but the warning light still does not go off, please contact the qualified workshop for treatment.

Service interval display



 Please refer to  at the start of the chapter on page 13.



Fig. 16 In the display of the instrument cluster: An example of the display when a maintenance project is due (schematic)

Maintenance item information can be displayed in the instrument cluster → Fig. 16.

The company has different models of instrument clusters, so display forms and items may vary.

The company's service interval is divided into two categories: oil replacement maintenance and regular inspection maintenance. Service interval display item displays the next maintenance information of the above two types of maintenance. Regular maintenance cycle and maintenance items can also be found in the maintenance manual.

According to driving time/mileage, the service interval of the vehicle is fixed.

Service interval prompt information

If the next required maintenance is about to expire, when turning on the ignition switch, the screen displays the **maintenance prompt message**.

The number of miles or days shown is the maximum distance and time that can be driven before the next maintenance.

Maintenance project



If a specified **maintenance is due**, after the ignition switch is turned on, the system will emit a signal tone, and the instrument cluster screen will display a wrench symbol  for a few seconds. The display screen may also display one of the following text messages → Fig. 16;

- Check your car condition immediately!
- Oil change maintenance immediately!
- Immediate oil change maintenance and vehicle condition check!

Check the service information

When the ignition switch is on, the engine is off and the vehicle is stationary, you can inquire the current maintenance information:

Models equipped with analogue instrument cluster:

- Press the button on the instrument cluster  until the service shows in the display. → page 14
- Release the button . The display displays the current maintenance information.



Models equipped with digital instrument cluster (basic):

- Vehicle maintenance information can be queried through the service menu → page 16.

Reset service interval display item



If the vehicle is not maintained by the qualified workshop after the expiration of an oil change maintenance or regular inspection maintenance, the Service Interval Display item can be reset as follows:

Models equipped with analogue instrument cluster:

- Switch off the ignition.
- Press and hold the button  → page 13 on the instrument cluster.
- Turn the ignition back on.
- If the instrument cluster displays one of the following information, release the button : **Whether to reset oil change maintenance data? or reset the vehicle condition check data?**
- Press the button  → page 13 on the instrument cluster to confirm.

Models equipped with digital instrument cluster (basic):

- The service interval display item can be reset through the service menu → page 16.

 When the engine is running, the maintenance information displayed after a few seconds will be hidden, or by pressing the  on the multifunction steering wheel for hiding the information → page 23. ◀

Operating instrument cluster

Introduction

This chapter contains information on the following subjects:

- Menu in the instrument cluster 24
- Operation using the multifunction steering wheel 24

Certain menu items can only be displayed when the vehicle is stationary.



WARNING

Driver inattention can lead to accidents and injuries. Operating a instrument cluster may interfere with a driver's observation of road conditions. ▶

- Do not open the menu on the instrument cluster while the vehicle is moving.

 Some system settings may be changed or deleted when the battery capacity of the 12-volt vehicle battery is low or the battery is replaced. After the battery is fully charged, check and update system settings again.

Menu in the instrument cluster

 Please refer to  at the start of the chapter on page 23.

The range and layout of the public information system menu depends on the vehicle electronic system and vehicle configuration.

The qualified workshop can program or change the relevant functions according to the vehicle equipment. Volkswagen recommends using a Volkswagen dealership.

Certain menu items can only be called up when the vehicle is stationary.

Driving data → page 17

Driver assist systems

Vehicle Status (depending on model equipment) → page 19.

Operation using the multifunction steering wheel











 Please refer to  at the start of the chapter on page 23.



Fig. 17 Right side of multifunction steering wheel: Keys for operating instrument cluster menu and information display (this type is an example only)

As long as an alert with a priority of 1 → page 19 is displayed, no menu can be brought up. Certain alarm information can be confirmed and hidden by the button  → Fig. 17 on the multifunction steering wheel.

Select menu or information display

- Switch on the ignition.
- If the display displays a message or a pictograph of the vehicle, press the button  → Fig. 17 on the lever as many times as necessary.
- Models equipped with analogue instrument cluster:*
To browse the selection menu, press the buttons  or  → Fig. 17.
- To open the menu display item or information display item, press the button  → Fig. 17 or wait a few seconds until the system automatically opens the menu or displays the information.
- Models equipped with digital instrument cluster (basic):* Depending on the information mode selected, the selection menu is available by the buttons  or , and then by buttons  or . ▶

↕ → Fig. 17 to browse the selection menu. Or directly by the buttons ▲ or ▼ → Fig. 17 to open and browse the selection menu.

- Press the buttons ⏪ or ⏩ to open the menu display item, and press the button OK → Fig. 17 to open the information display item and wait a few seconds until the system automatically opens the menu or displays the information.

Adjust menu settings

- Press the arrow buttons ▲ or ▼ → Fig. 17 in the displayed menu until the display displays the desired menu item. The selected menu item displays a checkmark through a box
- Press the button OK → Fig. 17 to make the required changes. "Check" mark indicates that the selected system or function is active.

Return to menu selection

Press the button ⏪ or ⏩ → Fig. 17 exit the menu.

Button VIEW in the multifunction steering wheel

Vehicles equipped with analogue instrument cluster: Button VIEW → Fig. 17 can be used to switch between the current and previous menus.

Vehicles equipped with digital instrument cluster: Button VIEW → Fig. 17 can be used to switch between different information modes.

 If the display displays fault alarm information when the ignition switch is on, certain settings or related information cannot be displayed as described above. In this case, you should go to the qualified workshop as soon as possible to rectify the problem.

Settings and display in the infotainment system

Introduction

This chapter contains information on the following subjects:

- Vehicle settings menu 25

Infotainment systems combine important vehicle systems into a central operating unit, such as menu settings, radio, and navigation systems.

General instructions on menus and system settings

The following sections introduce how to make adjustments to the vehicle settings through the **vehicle settings** menu. See → Booklet *Infotainment System* for information on how to operate infotainment systems and their alarm and safety instructions.¹⁾

System setting

Depending on the vehicle and equipment, click  or **Vehicle Settings** on the infotainment System, information can be displayed and settings can be adjusted by clicking on the corresponding function button.



WARNING

If the driver is distracted, this can cause accidents and serious injuries. Operating the Infotainment system can distract you from the road.

- Drive with your full attention and with responsibility.

 When you start the engine after the 12-volt vehicle battery has been totally discharged, replaced, or after a jump start, you may find system settings, e.g. Time, date, and personal convenience features have been changed or deleted. Check and correct the settings as necessary once the 12-volt vehicle battery has been sufficiently charged.

Vehicle settings menu

 Please refer to  at the start of the chapter on page 25.

You can switch individual functions and systems on and off and adjust the settings in the **vehicle settings** of the Infotainment system.

¹⁾ Depending on vehicle equipment, some vehicles do not provide this manual.

Opening the Vehicle settings menu

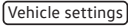
- Switch on the ignition.
- Switch on Infotainment system if necessary.
- Press  the button.
- Tap the function button , and select **Vehicle settings** menu.
- Tap the corresponding function buttons to open additional menus in the **Vehicle settings** menu or adjust the settings in the menu options.

Open the menu and set it as needed. Functions that are switched on are highlighted in colour.

Tap the function button  to return to the previous menu.

Safety precautions

General notes

Driving preparation and safety

In order to ensure the safety of you and all occupants of the vehicle, the following items must be observed before and during the journey → :

- ✓ Check that all lights and turn signals are working properly.
- ✓ Check tyre pressure and fuel stock → page 189, → page 21.
- ✓ Check the level of windscreen cleaning fluid → page 169.
- ✓ Make sure all Windows have a clear view → page 206.
- ✓ Ensure that the storage facilities in the car and the items in the luggage are reliably fixed → page 144.
- ✓ Ensure that nothing interferes with the pedal.
- ✓ When travelling with children in a car, ensure that the child is protected by an appropriate child protection system based on the child's height and weight → page 42.
- ✓ The front seat, head restraints and rearview mirror must be adjusted correctly according to the body type → page 28, → page 80.
- ✓ Drivers should wear shoes suitable for pedal operation.
- ✓ Footpads laid in the driver's side foot space must not interfere with pedal movement and must be securely secured.
- ✓ Be sure to maintain a correct posture before and during driving, and remind all occupants of the vehicle to maintain a correct posture → page 28.
- ✓ Wear seat belts properly before and during driving, and remind all occupants to fasten their seat belts → page 30.
- ✓ All occupants of the vehicle must sit in their own seats and must wear their seat belts.
- ✓ Do not overdrive.
- ✓ Do not drive when your reflexes are impaired. For example, drugs, alcohol or drugs can impair your reflexes. 

Driving preparation and safety (Continued)

- ✓ Do not let external factors distract you from traffic conditions while driving, such as talking to occupants, making phone calls, opening menus and adjusting system settings.
- ✓ Ensure that your speed and driving style are always appropriate for the current visibility, weather and road/traffic conditions.
- ✓ Strictly obey traffic regulations and legal speed limits.
- ✓ Stop and rest regularly on long journeys, at least once every two hours.
- ✓ Place your pet with a device appropriate for its weight and size.

Information for driving abroad

Safety standards and emission regulations adopted by some countries may be different from our vehicle structure. We suggest that you consult the qualified workshop on the following matters before travelling abroad by car to understand the relevant laws and regulations in the destination country:

- ✓ Does the car need to be adapted for foreign driving, for example, shielding or changing headlight settings?
- ✓ What maintenance/repair tools, diagnostic equipment and spare parts should I bring?
- ✓ Whether there are any Volkswagen dealership in the destination country?
- ✓ Is fuel oil available to meet the quality requirements in the destination country → page 147 ?
- ✓ Is the vehicle oil that meets our technical specifications available in the destination country → page 169 ?
- ✓ Is it necessary to install special tyres when travelling by car in the country of destination?
- ✓ Is it required to have a fire extinguisher when travelling by car in the country of destination?
- ✓ What are the special requirements of the destination country for luminous warning vests?

Checks when filling the tank

If you are not familiar with the operation process and safe operation procedures, or do not have appropriate equipment, tools and vehicle oil, you must not try to operate in the engine compartment without authorization, otherwise, it is easy to cause accidents, seriously injured people → page 165 ! In case of any doubt, it should be carried out by a correspondingly qualified workshop. When adding fuel, check the following items:

- ✓ Window cleaning fluid level → page 169
- ✓ Engine oil level → page 170
- ✓ Engine coolant level → page 174
- ✓ Brake fluid level → page 178
- ✓ Tyre pressure → page 183
- ✓ Conditions of vehicle lighting system closely related to driving safety → page 72 :
 - Turn signals
 - Side lights, headlamp dipped beam and headlamp main beam
 - Tail light clusters
 - Brake lamp
 - Rear fog lamp
 - License plate lamp

Replace the light bulb related instructions → page 155.

DANGER

Be sure to pay attention to the important safety tips regarding airbags on the front passenger sun visor → page 44, *Basic information on installing and using a child seat.*

WARNING

Alcohol, drugs, drugs or narcotics can affect drivers' driving behaviour, which can easily lead to serious accidents and deaths!

- Alcohol, drugs, drugs or narcotics can greatly reduce the driver's awareness and responsiveness, seriously endanger driving safety, resulting in vehicle loss of control!

WARNING

Be sure to obey traffic laws and speed limits and drive predictably. A good understanding of the driving environment can help you reach your destination safely and avoid serious injury or death.

- Take regular breaks on long journeys - at least every two hours.



NOTICE

Vehicle failures caused by the use of inferior fuel, improper maintenance or installation of spare parts other than the original factory are not covered by the quality guarantee.

 Regular vehicle maintenance not only helps to maintain the value of the vehicle itself, but also ensures that the vehicle is roadworthy and in good working condition. Therefore, it is important to maintain the vehicle regularly according to the provisions of the Maintenance Manual. If the vehicle is used in harsh conditions, such as frequent "stop-and-go driving", tractor-trailer driving and driving in high dust and cold areas, it is necessary to increase the number of maintenance items or shorten the maintenance period between the two regular maintenance. Please consult Volkswagen dealership for details.

- The number of people in the car shall not exceed the number of seats equipped with seat belts in the car.
- When driving with children, the appropriate protection system → page 42, *Child seats* and → page 37, *Airbag system* must be selected according to the height and weight of children to protect children.
- Keep your feet in their respective foot space at all times while driving. Do not rest your feet on the dash panel or extend them out of the window. Otherwise, the airbag and seat belt will not play a full protective role, and it is very easy to get injured in an accident.

Incorrect sitting position and potential risks

 Please refer to  at the start of the chapter on page 28.

Drivers who are not wearing seatbelts properly or are not wearing seatbelts are more likely to be seriously injured or killed in an accident. Only wearing the correct seat belt can give full play to the protective effect. Incorrect sitting posture will inevitably lead to incorrect seat belt wearing parts, greatly reducing the protective effect of the seat belt, which may cause serious injury or even death in the event of an accident. If the airbag is triggered at the same time, the airbag hits the car with the wrong sitting position, the injury will be more serious. Drivers must remind all occupants at all times to wear seat belts and maintain proper sitting posture.

The following incorrect posture may endanger all occupants of the vehicle.

When the vehicle is in motion:

- Never stand in a car.
- Do not stand on the seat.
- Do not kneel on the seat.
- Never recline your seat backrest too much.
- Do not lean on the dash panel.
- Do not lie on the car seat and rear row seat.
- Don't just sit in front of the seat.
- Do not lean against the side of the seat.
- Do not lean out of the window.
- Don't put your feet out of the window.

Correct sitting position

Introduction

This chapter contains information on the following subjects:

- Incorrect sitting position and potential risks 28
- Correct sitting position 29

Number of seats

The vehicle is equipped with 5 seats: 2 seats in the front and 3 seats in the back.

Each seat is fitted with a seat belt.

WARNING

When the vehicle suddenly starts driving or emergency braking, or when there is a collision and accident, or when the air bag is triggered, the driver and the passenger who is not sitting properly are prone to serious injury.

- All drivers and passengers must be seated correctly before the start of the vehicle and remain seated correctly at all times, even when wearing a seat belt.

- Never rest your feet on the dash panel.
- Never rest your feet on a cushion or backrest.
- Do not move in foot space.
- Do not sit on the armrests of the front and rear seats.
- Never move in a seat without wearing a seat belt.
- Do not carry people in luggage.

⚠ WARNING

In the event of an accident or rapid acceleration or emergency braking, the above incorrect posture greatly increases the risk of serious injury or death!

- All occupants of the vehicle must maintain a correct seated position and fasten their seat belts while driving.
- Improper sitting position, not wearing seat belt or too close to the installation position of the airbag will put the driver and passenger in the car in a dangerous situation, prone to serious injury or death in the event of an accident, especially when the airbag triggers impact on the occupant with incorrect sitting position, the injury will be more serious.

Correct sitting position

📖 Please refer to **⚠** at the start of the chapter on page 28.

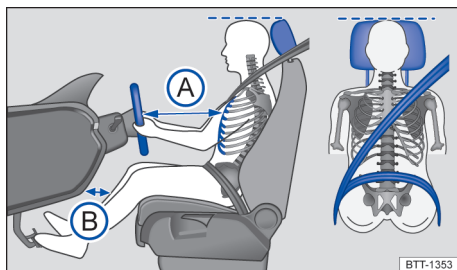

Fig. 18 Schematic diagram: Safe distance between driver and steering wheel, correct adjustment of seat belt and head restraints

The following sections describe the proper seated position for the driver and all occupants of the vehicle.

If the passenger cannot keep the correct sitting position due to the size, you can contact Volkswagen dealership, who will make special modifications to the seat according to your actual situation, so that you can keep the correct sitting position. Seat belts and airbags can only be fully protected if you sit correctly. We recommend that you take full advantage of this service provided by Volkswagen dealership.

For your safety and to reduce the degree of injury caused by accident or emergency braking, the company recommends that you take the following posture:

The following instructions apply to all drivers and passengers in the vehicle:

- Adjust the head restraints so that the upper edge of the head restraints is equal to the top of the head, but not lower than the eyes, and the back of the head should be as close to the head restraints as possible → Fig. 18.
- Small passengers should press the head restraints down to the lowest clamping position when adjusting the head restraints. Even so, the top of the passenger's head may still be lower than the upper edge of the head restraints.
- Tall passengers should raise the head restraints as far as possible when adjusting the head restraints.
- Keep both feet in their respective foot space at all times while driving.
- Properly adjust and fasten your seat belt → page 30.

Driver information:

- Adjust the seat backrest to the upright position so that the back can be fully fitted with the backrest.
- Adjust the steering wheel so that the distance between the chest and the steering wheel is at least 25cm **A**, and the steering wheel rim can be held with your hands and elbows slightly bent → page 64.
- The steering wheel must be facing the driver's chest, never his face.
- Adjust the front and rear positions of the driver's seat so that the driver can completely press the pedal to the bottom with a slight bend of the knee, and the distance between the dash panel and the knee area should be at least 10cm **B**.

- Adjust the seat height so that both hands reach the highest point of the steering wheel.
- In order to operate the vehicle at any time, the driver's feet must always be placed in the foot space in front of the seat.

Front seat passenger information:

- Adjust the seat backrest to the upright position so that the back can be fully fitted with the backrest.
- Recline the seat as much as possible to ensure that the airbag is fully protected if it triggers expansion.

Seat belts

Introduction

This chapter contains information on the following subjects:

– Warning lamp	31
– Frontal collisions and the laws of physics	31
– Consequences of drivers and passengers without seat belts fastened	32
– Seat belt protection	33
– Information for using seat belts	33
– Fastening and unfastening the seat belts	34
– Seat belt routing	35
– Belt retractor, Belt tensioner and Belt tension limiter	36
– Belt tensioner service and disposal	36

Be sure to check the condition of all seat belts regularly. If the seat belt base, coupling, seat belt winder or seat belt latch is damaged, the damaged seat belt parts should be replaced at the qualified workshop as soon as possible → . Volkswagen dealership has original spare parts compatible with the vehicle model, configuration and production year, and should replace the seat belt parts by the qualified workshop.

WARNING

Wearing seat belts improperly or not at all increases the risk of death and injury. Only proper wearing and use of the seat belt can give full play to its protective effect.

- Safety belts are the most effective means to reduce the fatality rate in an accident. Therefore, in order to protect the driver and all occupants of the vehicle, all drivers and passengers must wear safety belts correctly when the vehicle is in motion.
- All drivers and passengers must be seated properly, fasten their seat belts and wear their seat belts at all times, even when travelling in urban areas.
- When travelling with children, place them with proper protective systems for their weight and height, and fasten their seat belts → page 42.
- All occupants of the car should fasten their seat belts before starting to drive.
- The seat belt latch must be inserted into the respective seat latch and secured. If the latch of the seat belt is inserted into the latch of the seat of other occupants, the protective effect of the seat belt will be greatly reduced, and it is very easy to be seriously injured in the event of an accident.
- Do not allow foreign matter or liquid to enter the latch of the seat belt latch. Otherwise, the latch and seat belt will not function properly.
- Never unfasten your seat belt while driving.
- Never share a seat belt with two people!
- No occupant shall hold a child or infant while the vehicle is moving, and wear a seat belt.
- When wearing a seat belt, remove loose, bulky clothing (e.g., overcoats over coveralls) so as not to affect the wearing of the seat belt and its protective effect.

WARNING

Damaged seat belt not only can not play a protective role, but will affect the protective function of the seat belt, accident may cause injury, or even death!

- Be careful not to stick the seat belt in the door or seat mechanism, otherwise, it will damage the seat belt.
- If the seat belt base or other parts of the seat belt are damaged, the seat belt may tear during an accident or emergency braking.
- Damaged seat belts should be replaced immediately with new seat belts approved by the company for use on the vehicle. Seat belts damaged or stretched due to accidents

should be replaced at the qualified workshop in a timely manner. Seat belts must be replaced even if there is no apparent damage to the surface! At the same time, the seat belt fastening device should be checked for damage.

- Do not attempt to repair, modify or remove your seat belt yourself. All repairs of seat belts, seat belt winders and latches/latches shall be performed by the qualified workshop.

Warning lamp



Please refer to  at the start of the chapter on page 30.



Fig. 19 Warning light in the instrument cluster

When the vehicle starts to drive and the vehicle speed exceeds 25km/h without wearing the seat belt, or unbuckle the seat belt during driving, the system will emit a signal tone for several seconds and the warning lights  → Fig. 19 will flash at the same time.

When the ignition switch is turned on and the driver and front passenger fasten their seat belts, the seat belt warning light  goes off.

WARNING

Wearing seat belts improperly or not at all increases the risk of death and injury. Only proper use of the seat belt can give full play to its protective effect.

Frontal collisions and the laws of physics

Please refer to  at the start of the chapter on page 30.

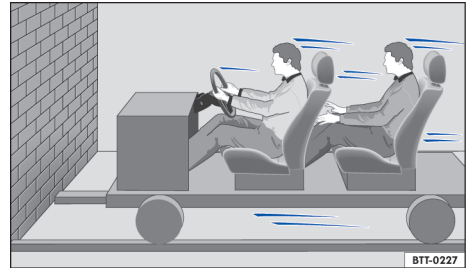

Fig. 20 The vehicle was driven towards a brick wall and none of the occupants were wearing seat belts

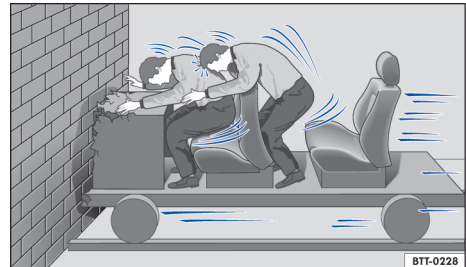

Fig. 21 The condition of a vehicle with unbelted occupants crashing into a brick wall

The physics of a head-on collision is fairly simple. When a vehicle is in motion, both the vehicle and the occupant → Fig. 20 have energy called “kinetic” energy.

The higher the speed and the greater the mass, the more energy is released in the event of an accident.

However, speed is the decisive factor. For example, when speed increases from 25km/h to 50km/h, kinetic energy will increase four times.

The amount of kinetic energy depends on the speed of the vehicle and the mass of the occupants. The higher the speed and the greater the mass, the more energy is released in the event of an accident.

The driver and passenger who are not wearing seat belts are not “integrated” with the vehicle. When a frontal collision occurs, the vehicle slows down, and the driver and passenger continue to

move forward at the speed before the collision until the movement is stopped by an object blocking the vehicle. In this case, the driver and passenger were not wearing seat belts and would have absorbed all the kinetic energy released by the impact point → Fig. 21.

Even if the vehicle is travelling at 30km/h to 50km/h, the force acting on the human body in a collision can easily exceed one ton (1,000kg). The higher the speed, the greater the force acting on the human body.

The physics of collision described in this example applies not only to frontal vehicle crashes, but also to all other types of accidents and collisions.

Consequences of drivers and passengers without seat belts fastened

📖 Please refer to ⚠️ at the start of the chapter on page 30.

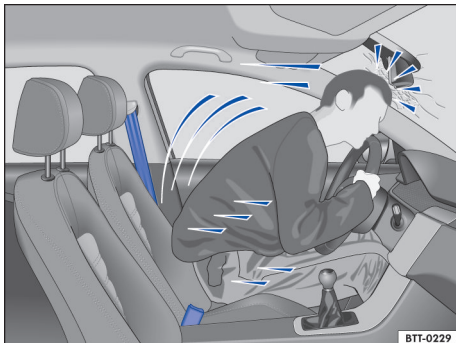

Fig. 22 The driver, who was not wearing a seatbelt at the time of the collision, was thrown violently forward

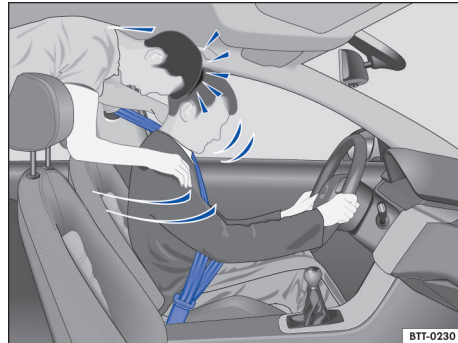

Fig. 23 The rear passenger, who was not wearing a seat belt at the time of the collision, was thrown forward violently, hitting the driver wearing a seat belt

Many people think they have control over their bodies when they are in a light collision, but this is a misconception!

Even at a low speed, the force on the human body is so great that it is impossible to control your body with your hands and arms. Drivers and passengers who are not wearing seatbelts in a head-on collision are thrown forward, slamming into the steering wheel, dash panel, windscreen or anything else in their path → Fig. 22.

Airbags should never replace seat belts! Airbags can only provide secondary protection in a crash. Not every type of accident can trigger an airbag. Therefore, even if the vehicle is equipped with an airbag system, all drivers and passengers must still wear seat belts while driving. In case of an accident, the seat belts can reduce the degree of death and injury, regardless of whether the air bags are present.

The airbag can only trigger once. For optimal protection, all drivers and passengers must wear seat belts at all times during the journey. In case of an accident, seat belts can provide effective protection even if the airbag does not trigger. Occupants who do not wear seat belts may be thrown out of the vehicle, causing more serious injuries or even death.

The rear passenger must also wear a seat belt, or they will be thrown violently forward in an accident, endangering not only themselves and the driver, but others in the car → Fig. 23.

Seat belt protection

📖 Please refer to ⚠️ at the start of the chapter on page 30.

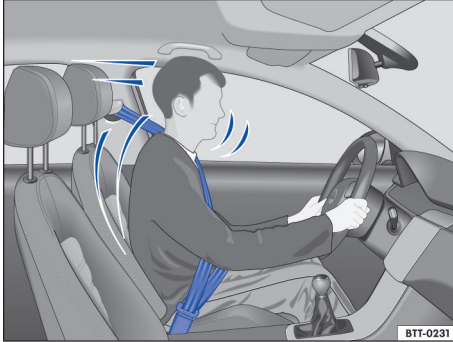

Fig. 24 Drivers who wear safety belts properly during emergency braking are effectively protected

It's important to wear your seat belt properly! Properly worn seat belts not only keep the driver and passenger in the correct position where they are less likely to be injured and absorb most of the kinetic energy of a collision, they also prevent out-of-control motion that could result in serious injury to the driver and passenger. In addition, properly worn seat belts reduce the risk of being thrown from the vehicle → Fig. 24.

The seat belt's primary function is to absorb most of the kinetic energy from a crash. The front end of the vehicle and other passive safety devices (e.g., airbag systems) are also designed to absorb collision kinetic energy. These safety devices, in conjunction with seat belts, further reduce the force acting on the passenger's body, effectively protecting the driver and passenger from accidents or minimizing injuries and deaths.

Although this example describes a head-on collision, proper seat belts can also protect drivers and passengers in other types of accidents and reduce the risk of injury or death. Therefore, everyone must wear a seat belt before driving -- even if they are "driving nearby" -- and urge all occupants to fasten their seat belts.

Traffic accident statistics show that the correct wearing of seat belts is an effective means to reduce accident casualty rate and improve occupant survival rate. At the same time, it can also make full use of the auxiliary protection effect of

airbags. Therefore, traffic laws in most countries require drivers and passengers to wear seat belts while driving.

Even if a vehicle is equipped with airbags, all drivers and passengers are required to wear seat belts for the following reasons: front-seat front airbags, for example, trigger in a serious frontal collision. However, when the vehicle has a mild frontal collision, a mild side collision, a rear collision, a rollover or an accident that does not exceed the airbag trigger limit set in the control unit, the system will not trigger the front front airbag, and only the seat belt provides protection for the occupants.

Therefore, always fasten your seat belt before starting to drive, and remind all occupants to fasten their seat belts! ◀

Information for using seat belts

📖 Please refer to ⚠️ at the start of the chapter on page 30.

Checklist

Information for using seat belts → ⚠️:

- ✓ Check the condition of all seat belts regularly.
- ✓ Seat belts must be kept clean.
- ✓ Do not let foreign objects such as liquids touch the seat belt and seat belt latch, or enter the seat belt latch.
- ✓ Do not damage the seat belt by clamping it in position. For example, be careful not to clamp the seat belt when closing the car door.
- ✓ Do not remove, modify or repair seat belts or any parts of seat belt fixtures yourself.
- ✓ Always fasten your seat belt before you start driving and wear it throughout the journey.

Twisted seat belt

If it is difficult to pull the seat belt out of the seat belt guide, the seat belt may return to the side panels too fast, causing the seat belt to become twisted.

- Grab the seat belt latch and slowly pull the seat belt out.
- Smooth the harness with your hands and slowly guide it back into the side trim. ▶

Even if you cannot smooth the seat belt and eliminate the distortion, you should still wear the seat belt while driving, but the twisted part of the seat belt should not be in contact with the passenger's body. In this case, you should go to the qualified workshop as soon as possible to repair the twisted seat belt.

⚠ WARNING

Be sure to use the seat belt correctly, otherwise, you will increase the risk of death or injury in an accident!

- Check seat belts and related components regularly to see that they are in good condition.
- Seat belts must be kept clean at all times.
- Do not let the seat belt stuck in position, or with sharp edge friction, to avoid damage to the seat belt.
- There should be no debris or liquid in the latch and latch of the seat belt.

Fastening and unfastening the seat belts

📖 Please refer to ⚠ at the start of the chapter on page 30.

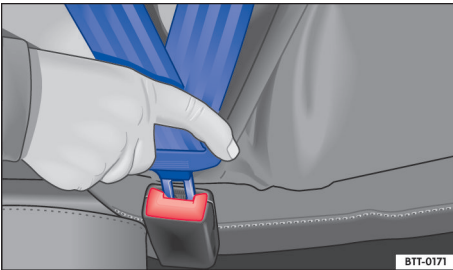

Fig. 25 Insert the seat belt latch into the latch

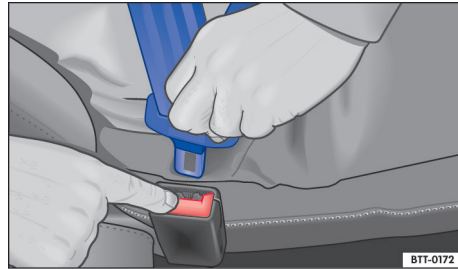

Fig. 26 Release the latch from the seat belt latch

Properly worn in the event of an accident or emergency braking, the seat belt can keep the driver and passenger in the correct position, avoid accident injury, or minimize injury and death → ⚠.

Wear a seat belt

Be sure to fasten your seat belt before starting to drive.

- Adjust the front seat and head restraints to the correct position according to your body type → page 28.
- The rear occupant locks the rear seat backrest into the upright position → ⚠.
- Grab the seat belt latch and slowly pull it across your chest and crotch **start immediately** twisting the seat belt → ⚠.
- Insert the latch into the seat belt latch of the respective seat → Fig. 25.
- Pull the seat belt to make sure the latch is stuck in the latch.

Unbuckle the seat belt

Unfasten the seat belt when the vehicle has come to a complete stop → ⚠.

- Press the red button on the latch, and the latch of the seat belt will pop out automatically from the latch → Fig. 26.
- For easy rewinding and no damage to the seat belt and interior panel, hold the lock tongue and send back the seat belt, and the automatic rewinding device will roll back the seat belt.

⚠ WARNING

In the event of an accident, wearing the wrong seat belt is very easy to injure, even kill the occupant! ▶

- The seat belt provides the best protection when the seat backrest is in an upright position and the occupant is wearing the seat belt correctly for his or her body size.
- Do not unfasten the seat belt while the vehicle is in the running state. Otherwise, the occupants may be seriously injured or die from their injuries in the event of an accident or emergency braking!

Seat belt routing

📖 Please refer to ⚠️ at the start of the chapter on page 30.

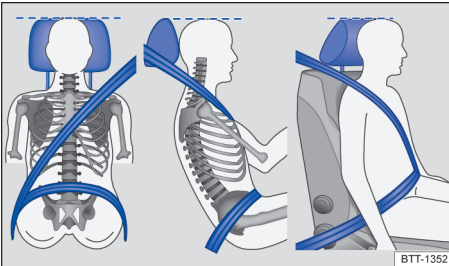

Fig. 27 Correct seat belt and head restraints alignment

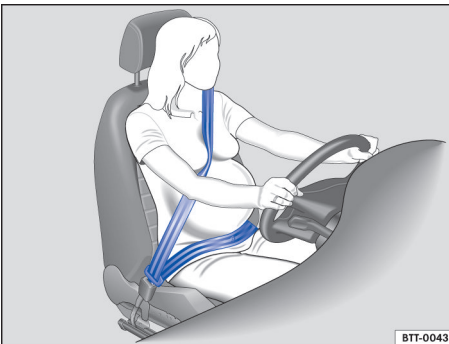

Fig. 28 The correct part of the seat belt for pregnant women

Wearing the correct part of the seat belt can give full play to the protective role in the event of an accident, reduce the accident casualty rate! It also keeps the occupants of the car in a position where the airbags are fully protective. Therefore, always wear your seat belt at all times and make sure it is worn correctly→ Fig. 27.

Occupants who are not sitting correctly during an accident can be seriously injured or even killed→ page 28, *Correct sitting position*.

The proper place to wear the seat belt

- The shoulder harness must be in the centre of the passenger's shoulder and must not be placed around the neck, under the arm or behind the back.
- The waist harness must be located in the pelvis and must not be pressed against the stomach.
- The seat belt must be flat and fit with the occupant. Tighten the seat belt if it is too loose.

For **pregnant woman** who wearing a seat belt, the shoulder belt must be placed in a suitable part of the chest and the waist belt in the pelvis should be as low as possible. The seat belt must be flat and free of pressure on the lower body of the pregnant woman - the pregnant woman should wear the seat belt accordingly throughout the pregnancy→ Fig. 28.

Adjust the seat belt to fit your body type

The following devices can be used to adjust the seat belt height:

- Front seats with adjustable height→ page 28.

⚠️ WARNING



In case of accident or emergency braking or in case of rapid acceleration, improper seat belt wearing may seriously injure the occupant!

- The seat belt provides the best protection when the seat backrest is in an upright position and the occupant is properly wearing the seat belt.
- If the seat belt is moved from a harder part of the body to a softer part of the body (for example, the stomach), an unfastened seat belt may seriously injure the occupant.
- The shoulder belt must be in the centre of the passenger's shoulder and must not be tucked under the arm or around the neck.
- The shoulder harness must be flat and fit against the passenger's chest.
- The waist harness must be located in the pelvis and must not be pressed against the stomach. The waist harness must be flat and fit into the pelvis. Tighten your seat belt if necessary.

- When a pregnant woman is wearing the belt, the waist belt in the pelvic area must be as low as possible, flat under the "raised" abdomen.
- Be careful not to twist the seat belt when wearing it.
- Never pull the seat belt away from your body with your hands.
- Never press the seat belt against hard or fragile objects such as glasses, pens or keys.
- Do not use seat belt clips, retainers, or similar devices to change the direction of the seat belt.

 If the seat belt cannot be worn on the right part of the body due to physical reasons, you can contact Volkswagen dealership to make special modifications to the seat belt so that the seat belt and airbag can fully play a protective role. This modification shall be carried out by the qualified workshop.

Belt retractor, Belt tensioner and Belt tension limiter

 Please refer to  at the start of the chapter on page 30.

The seat belt is an important part in the vehicle safety system → page 37, which has the following important functions:

Automatic seat belt retractor

The shoulder belt of this car is equipped with automatic retractor. The shoulder belt can be retractable at a slow pull or when the vehicle is travelling at normal speed. However, the shoulder belt cannot be freely retractable due to quick pulling, emergency braking, automatic retractor locking the belt when driving on mountain roads or curves and accelerating.

Seat belt tensioner

In the case of serious frontal collision, side collision and rear collision, the sensor triggers the seat belt better rate of development for electric vehicle, which will tighten the seat belt in the direction of rewinding and slow down the forward movement of the occupant, so as to protect the occupant. The seat belt tightener works in tan-

dem with the airbag system. In the event of a rollover accident, the seat belt tightener will not be activated if the side airbag is not activated.



A little smoke will be released when the seat belt tightener is triggered. This is a normal phenomenon. It does not mean that the vehicle is on fire.

Seat belt tighten limiter

In the event of an accident, the seat belt tighten limiter reduces the pressure of the seat belt on the occupant.

 Comply with relevant safety regulations when scrapping a vehicle or system component. The qualified workshop are familiar with the relevant regulations and can provide you with consulting services → page 36.

Belt tensioner service and disposal

 Please refer to  at the start of the chapter on page 30.

The seat belt tensioner may be damaged during operation or when the relevant parts of the seat belt tensioner need to be disassembled for maintenance of other parts of the vehicle. The surface of the damaged seat belt may show no obvious signs of damage, but the actual damaged seat belt in an accident may cause the seat belt tensioner to not work properly or not work at all.

Ensure that the safety belt tensioner is protected to prevent injury or environmental pollution caused by the removed parts. Strictly comply with relevant laws and regulations when handling the removed parts. The qualified workshop are familiar with the relevant regulations and can provide you with consulting services.

WARNING

If the safety belt, automatic seat belt retractor and seat belt tensioner are improperly used or repaired by non-professional personnel, the seat belt tensioner may not trigger when they should or should not trigger in an accident, thus increasing the risk of injury or death.

- The repair, adjustment or removal of any component of the tightening system or seat belt shall be performed by the qualified workshop → page 210.

- Seat belt tensioner and automatic seat belt retractor cannot be repaired and must be replaced!

 Airbag modules and seat belt tensioner may contain certain amounts of perchlorate. Be sure to follow the relevant regulations when handling them.

Airbag system

Introduction

This chapter contains information on the following subjects:

– Types of front airbag systems for front passenger	38
– Alarm/indicator lamp	38
– Troubleshooting	38
– Functions and introduction to the Airbag system	39
– Front airbags	40
– Side airbag	41
– Head airbag	42

The car has frontal airbags for the driver and front passenger. If the front seat, seat belt, head restraints and steering wheel are properly adjusted, front front airbags provide additional protection for the chest and head of the front passenger. But remember, airbag systems are only auxiliary protection, and never replace seat belts! Therefore, the front passenger and driver must wear seat belts even if the front seats are equipped with airbags.

WARNING

Do not rely solely on the protection provided by airbags!

- Even if an airbag is triggered in an accident, it only provides additional protection.
- Only when passengers wear seat belts correctly can the airbag system give full play to its protective role and reduce the risk of accident casualties → page 30, *Seat belts*.
- All drivers and passengers must be seated properly, fasten their seat belts and wear their seat belts at all times, even when travelling in urban areas.

WARNING

Nothing should come between the occupant and the airbag inflating area, otherwise, the risk of injury increases when an airbag is activated and expands. It can also change the inflating area of the airbag, or throw objects at the occupant.

- Do not carry anything in your hands or on your legs while driving.
- Do not load anything in the front passenger seat. In the event of emergency braking or emergency, the loaded articles may enter the airbag expansion range. Once the airbag triggers expansion, the articles may fly over the whole carriage under the impact of the high-speed expanding airbag, causing injury to the occupants.
- The occupants of the front seat and the outside seat of the back seat must not hold children, pets or any other objects, otherwise, it will occupy the expansion space of the air bag. Both adults and children must obey this rule.

WARNING

The airbag can only trigger once! Airbag systems that have been triggered by accidents must be replaced.

- The triggered airbag and any affected system parts shall be replaced as soon as possible with new parts approved by the company for the vehicle.
- The maintenance and modification of the vehicles shall be carried out by the qualified workshop who have the necessary tools, diagnostic instruments, maintenance materials and qualified professional and technical personnel.
- Airbag parts removed from end-of-life vehicles or recovered airbag parts shall not be used.
- Do not make any changes to the airbag components.

WARNING

When the airbag is triggered, a small amount of smoke may be released. This is a normal phenomenon. It does not mean that the car is on fire.



- The smoke emitted may irritate the skin and mucous membranes of the eyes and may cause breathing difficulties, especially in people with asthma or other health conditions. In this case, such people should get out of the car or open the Windows and doors to breathe fresh air.
- Wash hands and face with soap and water before meals if you have been exposed to the released soot.
- Never wipe eyes or touch open wounds with hands that have been exposed to smoke.
- If smoke and dust enter the eyes, wash the eyes with water in time.

WARNING

Solvent-containing cleaners can loosen the surface of the airbag module cover. If the airbag is triggered in an accident, the broken plastic could seriously injure the occupant.

- Do not clean the dash panel and airbag cover with solvent containing cleaning solution!

Types of front airbag systems for front passenger

 Please refer to  at the start of the chapter on page 37.



Airbag system

Only Volkswagen dealership can deactivate the front passenger front airbag

Characteristics of airbag system:

- Front passenger front airbag in the dash panel.
- The indicator light  in the instrument cluster is on.

Alarm/indicator lamp

 Please refer to  at the start of the chapter on page 37.





When the ignition switch is turned on, the system will perform a functional test and the alarm/indicator lamp will be on and off after a few seconds.

WARNING

If the airbag system is faulty, the airbag may not trigger properly, not trigger at all, or trigger when it should not trigger, resulting in serious injury or death.

- In this case, you should go to the qualified workshop as soon as possible to check the airbag system.
- Do not install child seats in front passenger seats. Remove installed child seats. Even if the front airbag is faulty, it can still trigger in an accident.

Troubleshooting

 Please refer to  at the start of the chapter on page 37.

The airbag system or seat belt tensioner is faulty

The yellow light keeps on. In addition, a message may be displayed on the instrument cluster.

The system identified a functional failure in at least one airbag or seat belt tensioner.

- Please go to the qualified workshop for repair.
- Check the airbag system and seat belt tensioner.

Deactivate the airbag system or seat belt tensioner with a diagnostic device

When the ignition is switched on, the yellow light goes on for about four seconds and then blinks for about twelve seconds. In addition, a message may be displayed on the instrument cluster.

Deactivate at least one airbag or seatbelt tensioner with a diagnostic device.

- Please go to the qualified workshop for repair.
- Check that the airbag system or seat belt tensioner must remain off.

Functions and introduction to the Airbag system

📖 Please refer to ⚠️ at the start of the chapter on page 37.

Airbags protect occupants in front and side crashes by slowing their movement in the direction of impact.

When an accident triggers the airbag, the system inflates the airbag through a gas generator. At this point, the airbag cover cracks and the airbag expands at high speed to cover the entire expansion area within milliseconds. Once the passenger wearing the seat belt begins to fall into the inflated airbag, the gas in the airbag immediately begins to escape under the pressure of the passenger's body and supports the passenger, slowing the inertial motion of the passenger and thereby reducing the risk of injury to the passenger. Airbags may protect the occupant, but they can also cause other injuries, such as swelling, bruising and abrasions. The air bag also generates friction heat when triggered.

The most important factors affecting the triggering of airbag are accident type, collision Angle, speed at the time of collision and the type of collision object. Therefore, even if the vehicle is obviously damaged, it does not mean that the airbag should be triggered.

Whether the airbag activates depends on the deceleration of the vehicle at the time of impact and the deceleration reference value preset by the electronic control unit. If the deceleration measured by the control unit during the collision is less than the baseline deceleration value preset by the control unit, the system will not trigger the airbag even if the vehicle is seriously damaged due to the collision. Therefore, the degree of damage to the vehicle, the cost of maintenance, and even the vehicle damage due to an accident cannot be used as indicators to determine whether the airbag is triggered. Due to the ever-changing environment of a vehicle when an accident occurs, it is impossible to specify a certain range of vehicle speed and reference value that the airbag should trigger, so it cannot cover all types of collision accidents and the impact Angle that the airbag should trigger. In addition, there are other important factors affecting whether the airbag triggers, such as the characteristics of the collider (soft and hard), the Angle of impact, and the speed of the vehicle.

The airbag can only be used as the auxiliary protection device of the three-point safety belt, and it can play the auxiliary protection role in the event of an accident and the deceleration value of the vehicle is enough to trigger the airbag. Because the airbag can only be triggered once and only in certain circumstances, and whether the airbag is triggered or not, the seat belt can provide protection for the occupant in any situation. For example, in a pileup, only seat belts can protect the occupants.

The airbag system is only one part of the passive safety system of the vehicle. Only when the vehicle occupants fasten their seat belts and sit correctly can the airbag effectively play a protective role ⚠️→ page 28.

The safety system of this vehicle is composed of equipment

The safety system of this vehicle consists of the following safety equipment. Depending on the vehicle configuration, the model you purchase may not have certain safety equipment.

- Optimized three-point seatbelt for all seats.
- Front seat belt tightener.
- Front seat belt tightening force limiter.
- Seat belt alarm light 🚨.
- Front passenger front airbag for seat ride identification.
- Front seat front airbag.
- Front seat side airbag.
- Left and right head airbags.
- Airbag alarm/indicator lamp 🚨.
- Control unit and sensor.
- Optimized for safety Highly adjustable head restraints.
- Adjustable steering column.
- Fixed point for child seat on the outside rear seat.
- The top tether of the child seat retainer.

The system will not activate the front, side, and head airbags if:

- The collision velocity is below the required reference value in the control unit
- The ignition switch was off at the time of collision.
- The vehicle deceleration measured by the control unit is too low in frontal collision. ▶

- In a mild side impact.
- In a rear collision.
- When the car overturned.

Front airbags

📖 Please refer to ⚠️ at the start of the chapter on page 37.

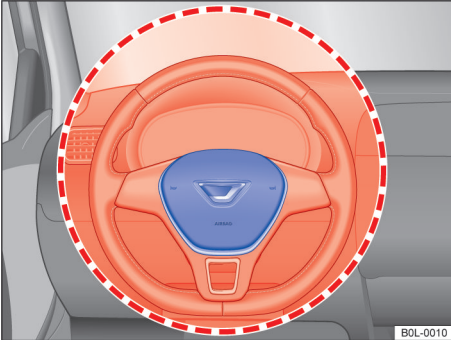

Fig. 29 Installation position and range of action of driver's frontal airbag

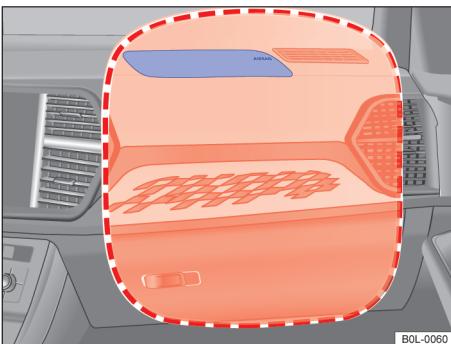

Fig. 30 Installation position and range of action of front passenger airbag

The front front airbag and seat belt provide additional protection for the head and chest of the front driver and passenger in severe frontal collision. The front passenger should be as far away from the front airbag as possible → page 28, *Correct sitting position*. This allows the front airbag to fully expand when triggered and thus provide maximum protection.

The driver's front airbag is in the steering wheel, → Fig. 29, and the front passenger's front airbag is in the dash panel → Fig. 30, marked with the letters "AIRBAG".

The area surrounded by the red lines in the figure is the action range of the front front airbag when it triggers expansion (expansion zone). Therefore, no items shall be stored or secured in this area → ⚠️. Driver and front passenger frontal airbags trigger without touching the original accessories.

⚠️ DANGER

When the vehicle collision triggers the airbag, the airbag instantly expands at high speed.

- The front front airbag should not be obstructed by anything within its expansion range.
- Do not install any position such as cup holders or telephone cages on the airbag cover or within the airbag expansion range.
- The front passenger shall not hold children, pets or objects to occupy the airbag expansion space. Both adults and children must obey this rule.
- Do not fasten anything (for example, portable navigation devices) to the windscreen above the front passenger airbag.
- Do not cover or paste anything or make any modifications to the steering wheel hub or the soft plastic surface of the front passenger side airbag assembly.

⚠️ WARNING

Remember, front airbags are in the steering wheel → Fig. 29 and the dash panel → Fig. 30.

- When driving a vehicle, the driver must always hold both hands at the 9 o'clock and 3 o'clock positions on the steering wheel rim.
- Adjust the driver's seat so that there is at least a 25cm gap between the chest and the wheel hub. If the minimum distance cannot be maintained for medical reasons, please contact Volkswagen dealership.
- Move the front passenger seat back so that the front passenger is as far away from the dash panel as possible.

Side airbag

📖 Please refer to ⚠️ at the start of the chapter on page 37.

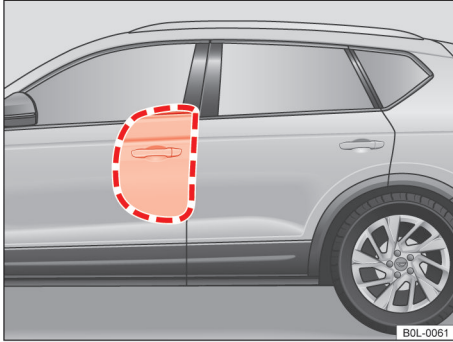

Fig. 31 Left side of vehicle: Expansion range of side airbag

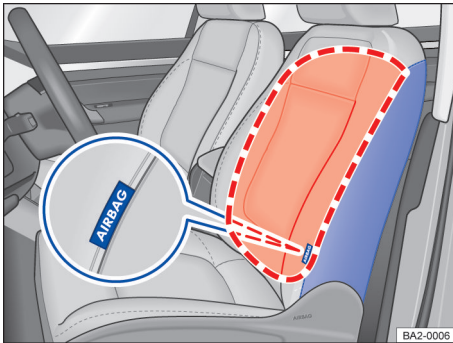

Fig. 32 Left front seat side: side airbag installation position and expansion range

Depending on vehicle equipment, front seat can be equipped with side airbag → Fig. 31:

- Front seat side airbags are installed in the driver seat and front passenger seat outboard backrest upholstery → Fig. 32.

Side airbag installation location is marked with the letters "AIRBAG".

→ Fig. 31 and → Fig. 32 The area surrounded by the red line in the two Figures is the range of action when the side airbag is activated and expands (the expansion zone). Therefore, no items shall be stored or secured in this area → ⚠️.

When a side impact occurs, the system triggers the side airbag on the collision side to provide protection for the passenger body on the collision side.

⚠️ WARNING

When the vehicle collision triggers the airbag, the airbag instantly expands at high speed.

- There must be no objects within the expansion range of the side airbag that impede the expansion of the airbag.
- The occupants of the front seat and the outside seat of the back seat must not hold children, pets or any other objects, otherwise, it will occupy the expansion space of the airbag. Both adults and children must obey this rule.
- The original coat and cap hook in the car can only be used to hang light clothing, clothing pockets do not load heavy or sharp objects.
- No accessories should be installed on the door!
- Seat sheathing (except for seat sheathing expressly approved by us for use in this vehicle) shall not be installed on the seat under any circumstances, otherwise the side airbag may not deploy if triggered by an accident.

⚠️ WARNING

Improper use of the driver's seat and front passenger seat may prevent side airbags from playing their protective role and result in serious injury.

- Do not remove the front seat from the vehicle or change the seat components.
- If too much pressure is applied to the side cushion of the backrest, the side airbag may not trigger properly, not trigger at all, or trigger when it should not.
- If the skin seams on the original seat skin or door airbag assembly are damaged, repair the damage at the qualified workshop as soon as possible.

Head airbag

📖 Please refer to ⚠️ at the start of the chapter on page 37.

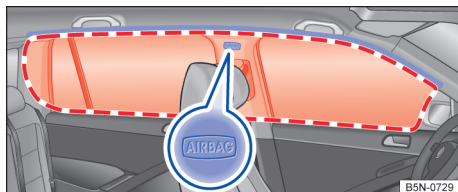

Fig. 33 Left side of vehicle: installation position and range of action of head airbag

Depending on the vehicle equipment, head airbags are mounted above the front left and right doors → Fig. 33.

The location of the head airbag is marked with the letters "AIRBAG".

The area delimited by the red dotted line → Fig. 33 is the coverage area (expansion range) when the head airbag is triggered. Therefore, no objects shall be placed or fixed in this area → ⚠️.

When a side impact occurs, the system triggers the head airbag on the collision side.

In the event of a side impact, the head airbag provides protection for the front seat and the outside rear seat on the impact side, reducing the risk of injury to the occupant.

⚠️ WARNING

When the vehicle collision triggers the airbag, the airbag instantly expands at high speed.

- There must be no object within the expansion range of the head airbag to obstruct the expansion of the airbag.
- Do not fasten any item to the head airbag cover or its range of action.
- The occupants of the front seat and the outside seat of the back seat must not hold children, pets or any other objects, otherwise, it will occupy the expansion space of the airbag. Both adults and children must obey this rule.
- The original coat and cap hook in the car can only be used to hang light clothing, clothing pockets do not load heavy or sharp objects.

- No accessories should be installed on the door!
- Shade screens shall not be installed on doors and Windows and shall be approved by Volkswagen dealership.
- When nothing is fixed on the visor (e.g., ball-point pen, etc.), pull the visor out and turn to the side window to block the sun. ◀

Child seats

📖 Introduction

This chapter contains information on the following subjects:

- | | |
|---|----|
| – Child seat type | 43 |
| – Basic information on installing and using a child seat | 44 |
| – Child seat securing systems | 45 |
| – Fix the child seat with lower fixed point (ISOFIX) | 46 |
| – Fix the child seat with top retainer strap (Top Tether) | 48 |
| – Fix the child seat with seat belt | 48 |

Child seats reduce the risk of injury to young children in the event of an accident. Therefore, when travelling with children, be sure to keep them in a child seat!

Please note:

- Child seats can be divided into different groups based on the child's height, age and weight.
- The child seat can be fixed to the car by different fastening devices.

For safety, child seats should always be mounted in the rear seat → page 44, *Basic information on installing and using a child seat.*

We recommend that you use the child seats in our original accessory series, as the child seats in this series are designed for our vehicles and approved by our company for use in our vehicles. Volkswagen dealership has child seats suitable for this car. ▶

⚠ WARNING

Children can be seriously injured or even killed when they are not protected by child protection systems or when child protection systems are not used properly. So please note:

- Children younger than 12 years old or less than 150cm tall are recommended to use a suitable child seat. If this regulation differs from the local regulations, please follow the local regulations.
- Be sure to choose appropriate protection system according to the children's age, height and weight to protect the children in the car.
- Only one child can fit in a child seat. Do not use seat belts to restrain more than one child in a child seat.
- Under no circumstances shall a driver or passenger hold a child or infant in his or her arms while the vehicle is in motion.
- Never leave a child unattended in a booster seat.
- Do not allow children to ride without safety protection. When the vehicle is moving, ensure that children keep a correct sitting position. Do not stand in the car or kneel on the seat. Especially when children sit in the front passenger seat should be more careful. If an accident occurs under these conditions, it may result in fatal injury to children and others.
- To maximize the protection of the child seat, ensure that the seat belt is properly worn. Be sure to follow the child seat manufacturer's instructions on proper seat belt wearing. Even minor accidents can result in injuries to children if the seat belt is not worn correctly.
- A child seat that has been subjected to force in an accident must be replaced, even if there is no visible damage, but may actually be damaged.

📌 NOTICE

Different countries may have different standards and regulations on the use and fixation of child seats. If the description in this manual is different from the local regulations and regulations, please comply with the local regulations. ▶

Child seat type

📖 Please refer to ⚠ and 📌 at the start of the chapter on page 43.



Fig. 34 Child seat diagram

Use only an officially approved seat that is suitable for the child.

Child seat standard

Child seats shall meet the GB27887 standard, and children seats that pass the test of this standard shall bear a qualified inspection mark. The inspection mark may contain the following child seat data:

- Weight class,
- Height class,
- License Class (General, Semi-General or model specific)
- License number.

Child seats by weight classes

Grade	Child weight
Group 0	Up to 10 kg
Group 0+	Up to 13 kg
Group 1	9 to 18 kg
Group 2	15 to 25 kg
Group 3	22 to 36 kg

- **Weight class 0/0+:** For children 0-18 months old, the best use of 0/0+ or 0/1 grade rear-facing infant seat → Fig. 34.
- **Weight class 1:** Group 1 (age 4 and younger) or Group 1/2 (age 7 and younger) child seats with built-in seat belts are best for children with appropriate weight limits.
- **Weight class 2/3:** Group 2 and 3 are divided into child seats with backrest and child seats without backrest. Backrest child seats are better protected than backless ones because they ▶

have built-in seat belt guides and side padding. Therefore, the company recommends the use of child seats with backrest. Two sets of child seats are suitable for children up to 7 years old, and three sets are suitable for children 7 years old or older.

Not all children fit the weight classification above. Likewise, not all seats are suitable to be installed in the car. Therefore, it is important to verify that the child seat is suitable for children to sit safely and can be reliably installed in the car.

Child seats by approval categories

Children seats can be divided into general purpose, semi-general purpose and vehicle special types according to the license category.

- **General purpose:** Universal child seats can be installed in all vehicles. No specific model needs to be listed. Universal child seats with ISOFIX need to be fixed by the Top Tether.
- **Semi-universal:** In addition to meeting the standard requirements of the general license, the semi-general License requires a safety device for securing the child seat, which is subject to additional testing. The semi-universal child seat comes with a list of applicable models. Only the train type listed in the list can use the child seat.
- **Model specific:** The vehicle-specific license requires the in-car dynamic testing of child seats for each applicable vehicle type. Special model child seat also has a suitable model list. ◀

Basic information on installing and using a child seat

📖 Please refer to ⚠️ and 🕒 at the start of the chapter on page 43.



Fig. 35 The airbag tag on the sun visor

Regulatory requirement

Standards and regulations for the use of child seats and their fixtures may vary from region to region. If the standards and regulations stipulate that it is not allowed to install a child seat or carry a child on the front passenger seat, please comply with the relevant requirements. The relevant regulations, standards and laws are superior to those described in this manual in principle.

Information about installing a child seat

When installing child seats, pay attention to the following tips. The following tips apply to child seats with any fixture.

- Carefully read and pay attention to the child seat instructions provided by the child seat manufacturer → ⚠️.
- Whenever possible, the child seat should be installed in the rear seat behind the front passenger seat so that the child alights on the side near the curb.
- If the rear-facing child seat is to be used in the front passenger seat, the front passenger front airbag must be turned off.
- When using a child seat in a front passenger seat, the front passenger seat must be moved back as far as possible. And put the seat backrest in an upright position → page 28.
- If it is necessary to install a child seat in the rear seat, leave enough space for the child seat. Push the front passenger seat forward into position if necessary. Make sure the driver or front passenger is sitting properly in the seat → page 28.
- Adjust the tilt of the seat backrest so that the child seat fits perfectly. If the seat head restraints is touched when installing the child seat and the child seat cannot fit with the seat backrest, push up or remove the seat head restraints behind the child seat completely and store it safely in the car → page 28.

Airbag sticker

The car may have stickers with important information about the front passenger airbag. Its content depends on the country and may vary. The sticker may be affixed in the following locations:

- On the visor above the driver and/or front passenger → Fig. 35.

Pay attention to the warning message before installing the child seat → ⚠️. ▶

Dangers of carrying children in front passenger seats

In the front passenger seat, **when using rear-facing child seat**, if the front passenger airbag is triggered, children may be seriously injured or even killed → .

If a rear-facing child seat needs to be installed on the front passenger seat under special circumstances, make sure that the front passenger front airbag is turned off.

In the front passenger seat, **when installing front-facing child seat**, the maximum distance between the child seat and the front passenger airbag should be kept as far as possible. Otherwise, children may be seriously injured when the front passenger airbag triggers expansion → .

Not every child seat can be used in the front passenger seat. Only child seat squares specifically approved by the manufacturer for mounting in front passenger seats equipped with front and side airbags are permitted. Volkswagen dealership keeps up-to-date information on all child seats authorized for use. For details, please consult Volkswagen dealership.

DANGER

If the child seat is mounted on the front passenger seat and the child is travelling with it, the risk of serious or fatal injury to the child in the event of an accident will be increased.

- Make sure the front passenger front airbag is disabled. If the front passenger airbag cannot be turned off, the child shall not be driven with the child in the child seat after the front passenger seat is used.
- Move back and raise the front passenger seat as far away from the front airbag as possible.
- Bring the seat backrest to an upright position.
- Use only child seats that have been approved by the manufacturer for use in front passenger seats with front or side airbags.

WARNING

Improperly installed child seats may injure occupants.

- Be sure to install the child seat strictly in accordance with the installation instructions and warnings provided by the child seat manufacturer.

WARNING

The use of a forward-facing child seat in the front passenger seat may seriously injure the occupant.



- Move back and raise the front passenger seat as far away from the front airbag as possible.
- Bring the seat backrest to an upright position.
- Child seats must be approved by the child seat manufacturer for use in front passenger seats equipped with front or side airbags.

WARNING

To avoid injury to children due to side airbags or head airbag triggering, it is necessary to:

- Make sure children are not within range of airbag expansion → page 37.
- Do not place anything within the expansion range of the side airbag.

Child seat securing systems

 Please refer to  and  at the start of the chapter on page 43.

The fixtures used to safely install child seats may vary from country to country.

Overview of fixtures

- **ISOFIX:** ISOFIX is a standardized fastening device for fast and secure child seat in the vehicle. The ISOFIX fixing device connects the child seat rigidly to the body of the car.

The child seat is equipped with two rigid fixing arms, which are inserted into the ISOFIX ring between the outside rear seat and the seat backrest. For ISOFIX fixed device connections, see → page 46. If necessary, Top Tether and foot fixing can be added on the basis of ISOFIX fixing device.

- **Three-point automatic seat belt:** When possible, the child seat should be secured using ISOFIX fastening devices, which are superior to the three-point automatic seat belt fastening method → page 48.

Additional fixtures:

- **Top Tether:** The top retainer strap is connected to it by a retainer hook. The retaining ring located on the rear seat backrest of the luggage compartment is connected → page 48. The Top Tether retaining ring is marked with an anchor icon.
- **Supporting foot:** Some child seats are supported on the floor of the car by support foot. The supporting foot prevents the child seat from tipping forward in a crash. Child seats with supporting foot can only be used in front passenger seats and outside rear seats → ⚠.
- **Baby seat or rear-facing child seat:** ISOFIX and Supporting foot.
- **when installing front-facing child seat:** ISOFIX and Top Tether, with supporting foot if necessary.

⚠ WARNING

Improper use of supporting foot can cause serious injury or even death to children.

- Make sure the supporting foot are properly and securely installed.

Recommended child seat fixtures

The company recommends fixing child seats in the following ways:

Fix the child seat with lower fixed point (ISOFIX)

📖 Please refer to ⚠ and ⌚ at the start of the chapter on page 43.



Fig. 36 Child seat ISOFIX fixed point identification mark

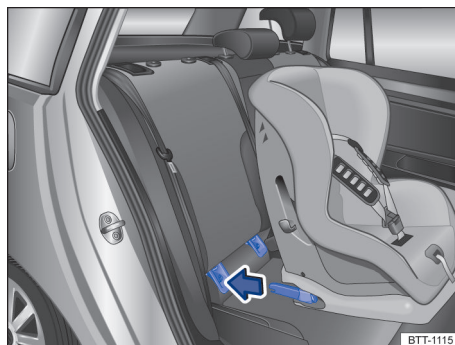

Fig. 37 Diagram: ISOFIX child seat is installed with fixed arm

ISOFIX Installation Overview

The following table lists the ISOFIX child seat installation position and installation method on each seat in the vehicle.

Grade	Child seat fixed direction	Dimensional class	Front passenger seat	Outside rear seat	Rear middle seat
Level 0: Up to 10 kg	backward	E	x	IL-SU	x
Level 0+: Up to 13 kg	backward	E	x	IL-SU	x
		D	x		x
		C	x		x
Level 1: 9 to 18 kg	backward	D	x	IL-SU IUF	x

Grade	Child seat fixed direction	Dimensional class	Front passenger seat	Outside rear seat	Rear middle seat
	forward	C	x		x
		B	x		x
		B1	x		x
		A	x		x
Level 2: 15 to 25 kg	forward	-	x	IL-SU	x
Level 3: 22 to 36 kg	forward	-	x	IL-SU	x

- **Dimensional class:** The size class corresponds to the permitted weight class for the child seat. For universal or semi-universal child seats, the ECE test mark lists the size class. The corresponding child seats are affixed with a size class description.
- **x:** This seat is not suitable for installing ISOFIX child seats of this class.
- **IL-SU:** The seat is suitable for mounting the semi-universal ISOFIX child seat. Please note the child seat manufacturer's applicable model list.
- **IUF:** The seat is suitable for mounting the universal ISOFIX child seat and is secured with Top Tether.
- Be sure to heed and follow the tips in → page 44, *Basic information on installing and using a child seat.*
- Push the fixing arm of the child seat to the ISOFIX fixing point → Fig. 37 in the direction of the arrow. You must be able to hear the sound of the child seat firmly stuck.
- Grab the left and right sides of the child seat and pull it out to check whether the child seat is firmly stuck.
- If the child seat is equipped with supporting foot, the supporting foot must be firmly supported on the floor of the car. <

Install ISOFIX child seat

The installation position of ISOFIX fixed point in the car is marked by symbols → Fig. 36.

Fix the child seat with top retainer strap (Top Tether)

📖 Please refer to ⚠️ and ⌚ at the start of the chapter on page 43.

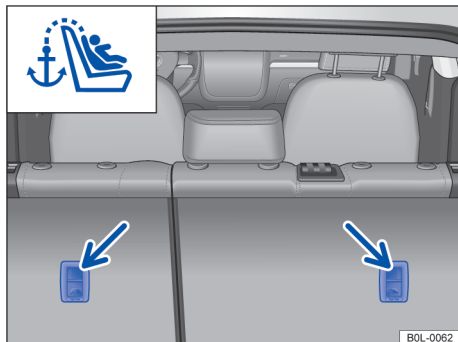

Fig. 38 A buckle on the backrest of the rear seat for attaching the top retainer strap

In addition to the ISOFIX fixation point, the universal child seat also needs to be attached by the Top Tether.

The retaining ring can only be used to secure the top retaining band. Depending on vehicle equipment, the fixing ring of the top retainer strap (Top Tether) can be identified by a graphic logo or the letters "TOP TETHER".

- Be sure to heed and follow the tips in → page 44, *Basic information on installing and using a child seat.*
- Release the seat backrest and flip it slightly forward → page 68.

- Remove the rear seat head restraints for installing the child seat and place the head restraints in a safe place in the car → page 65.
- Pass the top tether of the child seat backwards between the backrest and the luggage compartment cover and pull it into the luggage compartment. Remove the luggage compartment cover if necessary. → page 145
- Push the fixing arm of the child seat to the ISOFIX fixing point → Fig. 37 in the direction of the arrow. You must be able to hear the sound of the child seat firmly stuck.
- Attach the hook for the top retainer strap to the retainer ring on the rear seat backrest of the luggage compartment → Fig. 38.
- Return the seat backrest into place and push back hard to lock it.
- Tighten the retaining belt so that the upper part of the child seat is snug against the seat backrest.

Reinstall the seat head restraints immediately after removing the child seat → page 65.

⚠️ WARNING

Only use the specific retaining ring pre-installed in the car to connect the top retaining belt, otherwise it may result in serious injury.

- Do not *attach multiple* top retainer straps to the same retainer ring in the luggage compartment.
- Do not attach the top retainer to the baggage retainer ring.

Fix the child seat with seat belt

📖 Please refer to ⚠️ and ⌚ at the start of the chapter on page 43.

If a universal type (u) child seat is to be used in the vehicle, ensure that the child seat is approved for use in the corresponding seat. The necessary

information is available through the orange ECE inspection mark on the child seat. The following table lists the installation methods.

Weight classes	Child weight	Front passenger seat	Rear row seat
Group 0	< 10 kg	x	u
Group 0+	< 13 kg	x	u
Group 1	9 - 18 kg	x	u

Weight classes	Child weight	Front passenger seat	Rear row seat
Group 2	15 - 25 kg	x	u
Group 3	22 - 36 kg	x	u

u: universal; x: The seat is not suitable for the installation of a child seat of this class

Secure child seats with seat belts

- Be sure to heed and follow the tips in → page 44, *Basic information on installing and using a child seat.*
- Ensure that the seat belt is properly worn or threaded according to the child seat manufacturer's instructions.
- Do not twist the seat belt.
- Insert the latch into the seat belt latch of the respective seat and hear the latch stick. ◀

Operation Instructions in Emergency

Making you and your vehicle safe

When a vehicle breaks down, be sure to strictly follow the relevant safety regulations. For example, many countries require the use of hazard warning lights and high-visibility waistcoats when a vehicle breaks down → page 50.

Checklist

To ensure the safety of you and all occupants of the vehicle, please follow the following sequence → ▲:

1. Park your vehicle on a suitable surface away from the main lane → ▲.
2. Use the button  → page 10 to switch on the hazard warning light.
3. Switch on the electronic parking brake → page 123.
4. Put the selector lever in neutral → page 103 or move the selector lever to the gear P → page 104.
5. Switch off the ignition.
6. All occupants must exit the vehicle and wait in a safe place, for example, behind a safety barrier. Be aware of national regulations regarding high-visibility waistcoats.
7. Always take all vehicle keys with you when you leave the vehicle.

8. The warning triangle is set up in the corresponding position to attract the attention of drivers of passing vehicles.
9. Cool the engine sufficiently. If necessary, contact Volkswagen dealership.

Hazard warning lights should be turned on when the vehicle is being towed, but turn signals can still be used to indicate the direction to turn and change lanes. Temporarily switch off the hazard warning while the turn signals are working.

Switch on the hazard warning light when:

- When the vehicle in front slows down suddenly or waits at the end of the traffic flow due to traffic jam, the danger warning light should be turned on to attract the attention of the driver of the vehicle behind.
- In case of emergency.
- In case of breakdown.
- When towing while starting or towing other vehicles.

Be sure to use hazard lights in accordance with local regulations.

If the hazard warning lights fail, other corresponding measures which may attract the attention of other road users shall be taken, provided that the measures taken are in accordance with traffic laws.

WARNING

A broken down vehicle increases the risk of an accident, which can easily lead to accidents - endangering yourself and other road users.

- Stop as soon as practicable and safe to do so. ▶

- Park your vehicle in a safe position away from the main lane.
- Switch on the hazard lights.
- When locking the vehicle, keep children and people in need of help away from the vehicle. In case of emergency, do not lock the above people in the car. Otherwise, the people in the car may be exposed to high temperature or cold, and they are vulnerable to injury and disease.

⚠ WARNING

Ignoring any of the items listed above could result in death or injury!

- Be sure to strictly follow the above table and safety procedures.

⚠ WARNING

The components of the exhaust system become very hot and can lead to a fire and cause serious or fatal injuries.

- When parking a vehicle, ensure that exhaust system components do not touch any flammable materials such as hay under the vehicle.

ⓘ NOTICE

If you need to push the vehicle, do not press the taillight, rear spoiler and large steel plate surface with your palm, otherwise it may damage the vehicle and cause the rear spoiler to come loose.

i If the hazard warning light is on for a long time, the 12-volt onboard battery will discharge rapidly - even if the ignition is turned off.

i depending on the vehicle type equipment, when vehicle speed is higher than 80 km/h, the brake pedal is fully pressed, the brake signal light may flash to warn the following vehicle. If the braking state is maintained continuously, and the speed is lower than about 10 km/h, the danger alarm light will be automatically turned on and the brake signal light will keep on. If the vehicle accelerates, the hazard warning lights will switch off automatically.

First-aid kit, warning triangle, high-visibility waistcoat, and fire extinguisher

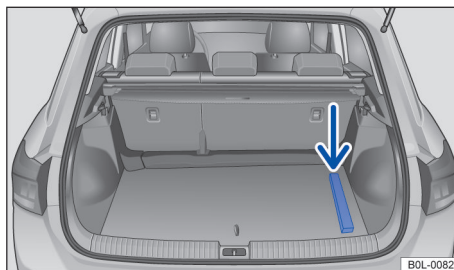

Fig. 39 In the luggage: Warning triangle

First-aid kit

Depending on the vehicle, the first aid kit can be stored in a storage compartment, on a bracket, or under the bottom of the luggage compartment.

The first aid kit must comply with relevant regulations, and the expiry date of the medicines in the kit must be noted.

Warning triangle

Depending on the vehicle, the warning triangle can be stored in the luggage compartment. Open the tail gate and take out the warning triangle.→ Fig. 39

Warning triangle must comply with national regulations.

After the warning triangle is used, it should be put back in the luggage.

High-visibility waistcoat

High-visibility waistcoats can be stored in a storage box on the driver's side door.→ page 8

High-visibility waistcoats must comply with national regulations.

Fire extinguisher

The fire extinguisher must be securely secured in the vehicle.

Fire extinguishers must meet the requirements of relevant regulations and must have their expiration date checked regularly to ensure that they are always available. The expiration date is marked on the inspection label of the fire extinguisher.

⚠ WARNING

Rapid acceleration or emergency braking in the car scattered items may be thrown out of place, seriously injured the car!

- Fire extinguishers, high-visibility waistcoats, first aid kits and warning triangle must be securely secured to their respective storage locations.
- Be sure to store high-visibility waistcoats in storage boxes for emergencies.

Switching on and off

Key kit

Vehicle key

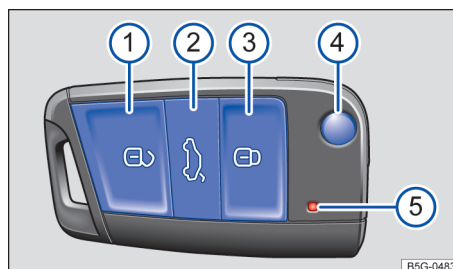





Fig. 40 Vehicle key

Fig. 40jump leads:

- ① Central locking button: Unlock the vehicle
- ② Unlock the tailgate separately
- ③ Central locking button: lock the vehicle
- ④ Open and fold the key head
- ⑤ Indicator: blinks when the button is pressed

Unlock or lock the vehicle from the outside

- *Unlocking:* Press the button .
- *Locking:* Press the button .
- Press the button  → page 59 to unlock the tail door.
- *Unlocking:* All turn signals are flashing *twice*.
- *Locking:* All turn signals are flashing *once*.

⚠ WARNING

Be careful when using keys. Improper use or management may result in accidents or injuries.

- When leaving the vehicle, take all vehicle keys with you to prevent children or others in the vehicle from locking the doors and tailgate, starting the engine, turning on the ignition, operating electric windows and other electrical equipment in the vehicle.
- Do not leave children or individuals who need assistance alone in the vehicle. In case of an emergency, they may become trapped in the vehicle and unable to safely evacuate or seek help. For example, closed vehicles

may be extremely hot or cold depending on the seasons, exposing occupants to a high risk of injury and illness, and even death, especially affecting children.

- Never remove the key from the ignition lock while the vehicle is in motion. Otherwise, the steering lock may engage and you will no longer be able to steer the vehicle. This can result in accidents and serious or even fatal injuries.

NOTICE

Every car key contains electronic components, so keep them safe from damage, moisture and strong vibration.

NOTICE

Frequent use of the comfort and convenience feature or unnecessary pressing of the key button will accelerate the battery drain in the key.

Replace batteries

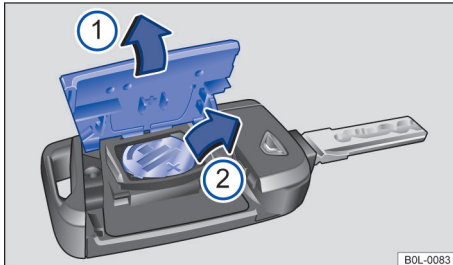

Fig. 41 Vehicle keys: Replace button batteries

Fig. 41 jump leads:

- ① Cover plate
- ② Button battery

It is recommended that you change the button battery at the qualified workshop → ①.

- Turn the head of the key.
- Pry up key cover plate ① → ①.
- Remove button battery ② from battery case.
- Place the new button battery in the battery case → ①.
- Press the cover plate ① back onto the key housing and clamp it.

DANGER

Diameter of 20mm battery or other lithium battery accidentally swallowed or stuck into the trachea, in a short time can make people suffocate or serious injury, even death!

- Keep keys, key rings, batteries, spare batteries, and other batteries larger than 20mm in diameter safe from children.
- If the key cover plate cannot be pressed back, do not use the remote key.
- If a battery is swallowed by mistake, seek medical attention as soon as possible.

NOTICE

- Improper battery replacement may damage vehicle keys.
- The use of inappropriate or non-compliant batteries may damage vehicle keys. Only new batteries of the same rated voltage, size, and specifications can be used to replace the dead batteries.
- Make sure to install the battery as described above. Key damage due to battery replacement is not covered by quality guarantee.

Waste batteries must be disposed of in strict accordance with the relevant provisions of the Environmental Protection Law.

Vehicle key synchronization processing

If the remote key can no longer be used to open or lock the vehicle, synchronize the vehicle key or replace the button battery → page 52.

- Turn the head of the key.
- Remove driver's side door handle cover → page 56.
- Stand near the vehicle.
- Press the button on the key .
- Unlock the vehicle with the vehicle key.
- Install the driver's side door handle cover → page 56.

Key synchronization is complete.

Troubleshooting

Vehicle cannot be locked or unlocked

Radio remote controls are subject to interference from obstacles, adverse weather conditions, or transmitters (such as mobile communications devices) operating in the same band near the vehicle.

Or: Central locking system closes for a short time to prevent system overload.

- Close the driver's door.
- **Or:** Synchronize the vehicle keys → page 52.

The indicator in the key does not blink

If you press the button and the indicator light in the key does not blink, it indicates that the battery in the key must be replaced → page 52.

 Spare or replacement keys may be ordered from the qualified workshop.

Keyless lock/start system Keyless Access (Keyless Access)

Introduction

This chapter contains information on the following subjects:

- Keyless Access (Keyless Access) for locking or unlocking the vehicle 53
- Troubleshooting 54

The Keyless Access system locks or unlocks the vehicle without a key. Therefore, a valid vehicle key is required within the vehicle's proximity range.

Keyless Access (Keyless Access) for locking or unlocking the vehicle

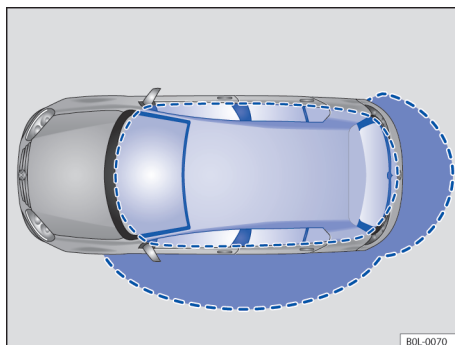

Fig. 42 Keyless Access lock/start system: Close range

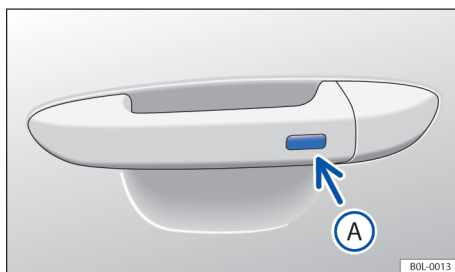

Fig. 43 Door handle: Keyless Access function button

Unlock and lock vehicles

Unlocking:

- Press function button → Fig. 43 (A) on the driver's side door handle.

Locking:

- Switch off the ignition.
- Close the driver's side door.
- Press function button (A) on the driver's side door handle.

All turn signals are flashing *twice* indicating vehicle unlocked, flashing *once* indicating vehicle is locked.

Lock and unlock the tailgate

If the vehicle is locked and a valid vehicle key is within close range of the tailgate → Fig. 42, the tailgate will automatically unlock when opened.

Tailgate locks automatically after closing.

If the vehicle is fully unlocked, the tailgate will **not** automatically lock after closing.

Temporarily disable the Keyless Access

To prevent others from unlocking and starting the vehicle without permission, the Keyless Access system can be temporarily disabled in the following manner.

- Use the button  on the vehicle key to lock the vehicle.
- In addition, press the function button → Fig. 43 (A) on the driver's side door handle within five seconds.
- Temporarily disable the Keyless Access system.
- Wait at least ten seconds before pressing the function button on the driver's side door handle to check the closure. The door should not open.

The next time you unlock the vehicle, you can only unlock the vehicle with the vehicle key. Unlocking the vehicle will reactivate the Keyless Access system.

 After the vehicle is locked, the unlocking feature of the Keyless Access system will be turned off for a few seconds to check if the vehicle has been successfully locked.

 For models equipped with an automatic gearbox, only the selector lever is in gear **P**, can the vehicle be locked.

Troubleshooting

Keyless Access System fails

The function button on the door handle fails

- Please go to the qualified workshop for repair.

 If the information **Keyless Access function invalid** is displayed on the instrument cluster, the Keyless Access system may have a function failure. Please contact the qualified workshop for repair.

 If there is no valid vehicle key in the car or the system does not detect a vehicle key in the car, the instrument cluster will display the corresponding information. This may also occur if the vehicle keys are blocked by other radio signals (e.g., mobile phones) or by objects (e.g., aluminum boxes, computers or briefcases). → page 97

Doors and central locking system

Introduction

This chapter contains information on the following subjects:

– Auto Lock and Auto Unlock	55
– Central locking button	55
– Manual opening or closing the driver door	56
– Manually closing the front passenger door and rear doors	57
– Childproof lock	57
– Troubleshooting	58

When the vehicle key or central locking system fails, the door and tailgate can be manually locked or unlocked.

All doors, tailgate and fuel tank caps are locked or unlocked through the central locking system.

Lock the vehicle only when leaving the vehicle after the ignition switch has been turned off or the engine has been turned off.

The instrument cluster → page 15 displays symbols indicating that one or more doors have not closed properly.  **Do not drive on!** Open the appropriate door and close it again.

◀ The symbol is still visible when the ignition switch is turned off, and about tens of seconds after closing all doors and locking the vehicle the displayed symbol is extinguished.

WARNING

An open door may suddenly open on its own while a vehicle is driving, causing serious injury or death!

- You must stop immediately and close the doors.
- Ensure that all doors are securely locked, with closed doors flush with the surrounding body of the car.
- When closing the door, be careful to ensure that no one is between the door and the door frame to avoid injury.

⚠ WARNING

In strong winds or when the vehicle is parked on a ramp, doors held open with door stops may suddenly close on their own, causing injury!

- Be sure to hold the door handle tightly when opening and closing the door.

⚠ WARNING

The opening/closing area of the door and tailgate is a dangerous area. Beware of injury during operation.

- Be careful when opening or closing doors and tailgate. Ensure that no one is between the door or tailgate and the door frame.

⚠ WARNING

Improper use of the central lock may cause serious injury.

- Central locking system locks all doors. After the vehicle is locked inside the vehicle, it can prevent the door from unintentionally opening and prevent others from illegally entering the vehicle. But in an accident or emergency, a closed door can also delay the rescue of the occupants.
- Do not leave children or people in need of assistance alone in the car. Use the central locking button to lock all doors in the car. This can cause them to barricade themselves inside their vehicles, and those trapped inside can suffer from extreme heat or cold.
- Depending on the season, temperatures in a locked vehicle may be extremely high or extremely low, exposing occupants to a high risk of injury and illness, and even death, especially affecting children.
- Do not leave anyone in a locked car. Those who remain in the vehicle during an emergency may be trapped in the vehicle and unable to evacuate safely or save themselves.

ⓘ NOTICE

Be careful when disassembling and assembling parts after manually closing or opening the vehicle in an emergency to avoid damaging the vehicle

Auto Lock and Auto Unlock

📖 Please refer to ⚠ and ⓘ at the start of the chapter on page 54.

Auto Lock

The vehicle automatically locks when the speed exceeds 15km/h. If the vehicle is locked, the indicator light  in the central locking button is lit yellow.

Auto Unlock

All door and tailgate locks of the vehicle will be unlocked automatically under the following conditions:

- When the vehicle stops and the vehicle key is pulled out.
- *Vehicles with an automatic gearbox:* When the selector lever is in gear **P**, and the ignition switch is off.
- **Or:** When the vehicle has stopped and pressing the button  until the yellow light goes off.
- **Or:** When pulling the door handle.
- **Or:** In the event of an accident and an airbag activation → page 58.

When the airbag is activated, the automatic unlocking function allows rescuers to enter the car. ◀

Central locking button

📖 Please refer to ⚠ and ⓘ at the start of the chapter on page 54.

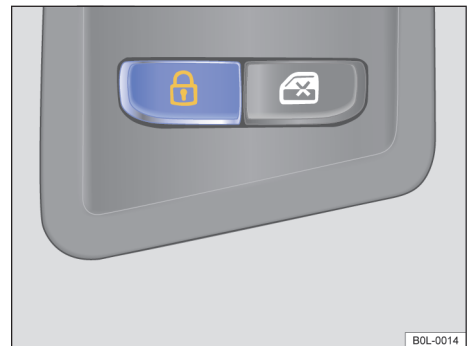

▶ Fig. 44 Driver's side door: Central locking button ▶

Fig. 44 jump leads:

🔒 Unlock/lock the vehicle.

When all doors are closed, the central locking button will work properly regardless of whether the ignition is on or off.

If the vehicle key has been used to lock the vehicle, the central locking button does not work.

If the central locking button has been used to lock the vehicle inside the car, it will appear:

- When all doors are closed and locked, the indicator light 🚗 in the button lights up yellow.

A door can be opened from inside the car by pulling the door open handle. When the door opens, the light in the button goes out 🚗. Open doors and tailgate remain locked and cannot be opened from outside the vehicle.

Manual opening or closing the driver door

📖 Please refer to ⚠️ and ⌚ at the start of the chapter on page 54.

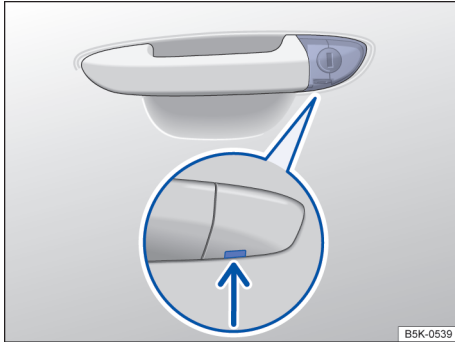

Fig. 45 Driver door handle: concealed door lock core

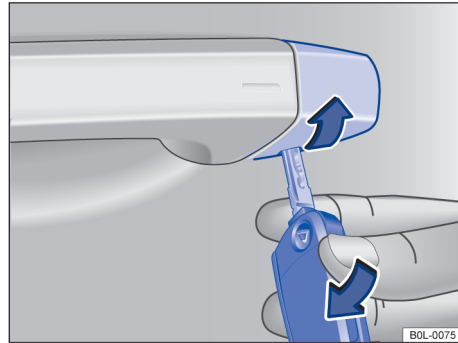

Fig. 46 Driver door handle: pry up the cover

After manually locking the driver door lock, check that all doors are locked. If not, lock manually;

◀ After manually unlocking the driver door lock, only the driver door can be unlocked;

- Pull the door handle outward until the cover is removed.
- Insert the key head from below into the notch in the driver door handle.
- Put your index finger under the head of the key.
- Use the vehicle key to pry up the cover in the direction of the arrow → Fig. 46.
- Insert the vehicle key into the lock cartridge to unlock or lock the vehicle.
- Pull the door handle and reinstall the cover.

After manually locking the vehicle, the Keyless Access will not be activated → page 53.

Condition when manually unlocking the vehicle

- After unlocking, perform emergency start → page 97.

The engine's electronic anti-theft stop system identified a valid vehicle key. ▶

Manually closing the front passenger door and rear doors

📖 Please refer to ⚠️ and ⌚ at the start of the chapter on page 54.

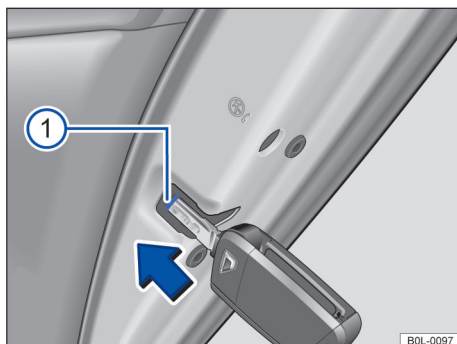

Fig. 47 In the front edge of the rear right-hand door: locking the vehicle with the emergency key

The front passenger side door and rear door can be manually locked.

- Open the car door.
- Insert the key bit into slot → Fig. 47 ⌚ and press it in the direction of the arrow until the locking device in the slot is stuck.
- Close the vehicle door.
- Check to see if the doors are locked.
- If necessary, lock other doors as described above.
- Check the vehicle at the qualified workshop as soon as possible.

Unlock the vehicle or open the corresponding door from inside the vehicle, and the manually locked door will be re-unlocked.

i The door can be unlocked and opened by pulling the door open handle from the car. <

Childproof lock

📖 Please refer to ⚠️ and ⌚ at the start of the chapter on page 54.

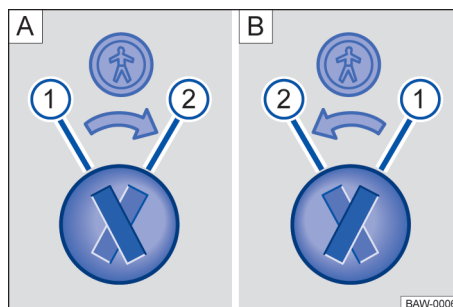

Fig. 48 Childproof lock: **A** Left rear door, **B** right rear door

Fig. 48 jump leads:

- ⌚ Disable the Childproof lock.
- ⌚ Enable the Childproof lock.

Childproof locks prevent children from opening the rear doors inside the vehicle.

The rear door can only be opened from the outside of the car after the Childproof lock is activated.

Disable or enable the Childproof lock

- Unlock the vehicle and open the corresponding rear door.
- Rotate the notch to the desired position.

! WARNING

The rear door cannot be opened from inside the car after the Childproof lock is activated.

- Never leave children or people in need of assistance alone in a locked vehicle as they may be trapped in the vehicle. In an emergency, these personnel may not be able to evacuate the vehicle or save themselves. Those trapped inside could be subjected to extreme heat or cold.
- The temperature in a locked car may be very high or very low depending on the season, which puts people inside the car at high risk of injury and illness, and even death, especially affecting children. <

Troubleshooting

📖 Please refer to ⚠️ and ⓘ at the start of the chapter on page 54.

The turn signals are not shining

If the turn signals *not* flash when locking the vehicle:

- At least one door or tailgate is left open.
- **Or:** When performing Easy closing, all electric windows are not closed.

The vehicle automatically locks

If any of the following conditions are met, the vehicle will re-lock automatically after approximately 45 seconds.

- Vehicle unlocked, but not opened.
- The ignition switch is not turned on.
- The tailgate is not open.
- Manually unlock the vehicle through the lock core.

The response of the vehicle when it is locked with another vehicle key

Keyless Access System: If another key is used to lock the vehicle outside the car, the key inside the car will be locked and the engine cannot be started → page 97. To obtain permission for the car key to start the engine, press the button on the car key. ⓘ

Lock the vehicle after triggering the airbag

If the airbag triggers in the event of an accident, the entire vehicle unlocks automatically. Depending on the degree of damage to the vehicle, the following ways can be used to lock the vehicle after an accident:

- Switch off the ignition.
- Open the driver's side door and close it.
- Lock the vehicle.

ⓘ If the 12-volt battery or button battery in the vehicle key has low or no power, the Keyless Access function may not be used to unlock or lock the vehicle. The vehicle can be unlocked or locked manually → page 54.

ⓘ If there is no valid vehicle key in the car or the system does not detect a vehicle key in the car, the instrument cluster will display the corresponding information. This may also occur if

the vehicle keys are blocked by other radio signals (such as mobile phones) or are covered by objects (such as aluminum boxes, computers or briefcases) → page 97. <

Tailgate

📖 Introduction

This chapter contains information on the following subjects:

- Tailgate opening and closing 59
- Manual unlocking the tailgate lock 60
- Troubleshooting 60

Tailgate and door can be unlocked and locked at the same time.

⚠️ WARNING

Exercise caution when unlocking, opening, or closing the tailgate. Otherwise, an accident may occur, causing serious injury.

- Therefore, be careful when closing the tailgate to ensure that no one is between the tailgate and the door frame to avoid injury.
- After closing the tailgate, carefully check to ensure that the tailgate is closed and securely locked to prevent it from opening on its own during driving. The closed tailgate must be flush with the surrounding adjacent body.
- The tailgate must always be closed when the vehicle is running to prevent harmful exhaust gas from entering the car!
- The tailgate and all doors must be closed and locked when the vehicle is not in use. Make sure no one is inside before closing.
- When the tailgate is open, do not allow children to play alone in the car or beside the car. Children may enter the luggage and close the tailgate, trapping themselves in the luggage. Depending on the season, the temperature in a locked car may be very high or very low, which puts people in the car at high risk of injury and illness, and even death, especially for young children. ▶

- Do not leave children or persons in need of assistance alone in the vehicle as they may lock the vehicle with the vehicle key or the central locking button, thus trapping themselves in the vehicle.

⚠ WARNING

Unlocking or opening the tail door improperly or unsupervised can result in serious injury.

- It may not be possible to accurately determine whether the tailgate has been unlocked when a luggage rack is mounted on it and there is a load on it. The unlocked tailgate may open suddenly during driving.

⚠ WARNING

When the tailgate is covered with heavy snow or loaded with heavy loads, the tailgate may close on its own under the action of additional loads and cause serious injury.

- Do not open the tailgate when it is heavily covered with snow or when there is a load (e.g. on the luggage rack).
- Open the tailgate and clear the snow or unload the load first.

⚠ WARNING

When closing the tailgate, do not press the rear window glass on the tailgate. Otherwise, the rear window glass may break, causing injury.

ⓘ NOTICE

Tailgate opening mechanism shall not be used to secure cargo or as a handle. Otherwise, the tailgate may be damaged and cannot be closed.

ⓘ NOTICE

The rear window wiper or spoiler shall not be used to hold the load or as a handle, otherwise it may damage the rear window wiper or break the rear spoiler.

Tailgate opening and closing

📖 Please refer to ⚠ and ⓘ at the start of the chapter on page 58.

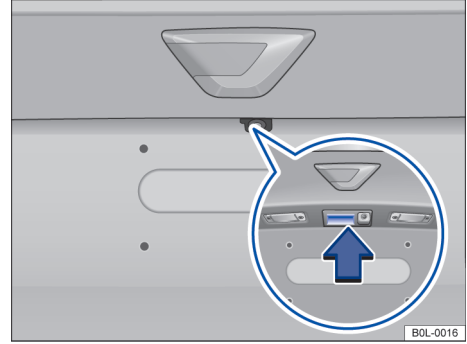

Fig. 49 Open the tailgate from the outside

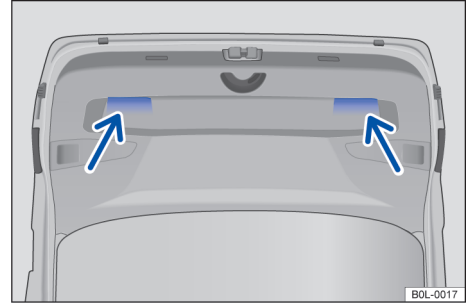



Fig. 50 Open tailgate: recessed handle for closing the tailgate

Open the tailgate

- Press the button  on the vehicle key to unlock the tailgate or fully unlock the vehicle, and open the tailgate by pressing the button → Fig. 49 (arrow);
- Or: Press the button  on the vehicle key until the tailgate automatically opens for several millimeters, and open the tailgate by pressing the button → Fig. 49 (arrow);
- After opening the tailgate, push the tailgate up to stop position.

Close tailgate

- Hold the recessed handle → Fig. 50 on the tailgate interior panel and pull the tailgate down slightly until it snaps into the tailgate lock → ⚠.

When the door is locked, the tailgate will be locked.

The instrument cluster → page 15 displays whether the tailgate is open or not closed correctly.

The tailgate locks automatically during driving.

! WARNING

Improper or unsupervised closing of tailgate may result in serious injury.

- When closing the tailgate, please ensure that your hand is out of the reversing range of the tailgate.

i If the tailgate is not opened within a few minutes after being unlocked, the tailgate automatically relocks.

Manual unlocking the tailgate lock

📖 Please refer to **!** and **🕒** at the start of the chapter on page 58.

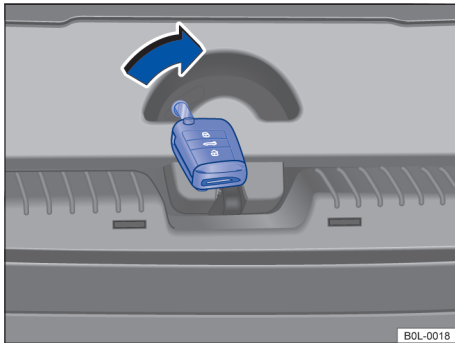

Fig. 51 Luggage: Open the tailgate lock

Unlock the tailgate manually

- Fold the rear seat backrest forward if necessary → page 67.
- Remove items from the luggage compartment so that the tailgate can be reached in the car.
- Insert the key head into the circular notch on the tailgate lock and push the unlocking lever → Fig. 51 in the direction of the arrow while pushing the tailgate outward until it opens.

Troubleshooting

📖 Please refer to **!** and **🕒** at the start of the chapter on page 58.

The tailgate cannot be opened or closed

- Check the tailgate for obstructions. The tailgate can be moved by hand, but with greater force.

The tailgate is stuck

When the ambient temperature is below 0°C, the tailgate opening mechanism may not automatically support the opened tailgate, so it is necessary to lift the tailgate by hand.

Electric windows

Opening and closing the electric windows

Electric window buttons on the door → page 5.

- 🔓** To open doors and windows: press the button; Close doors and windows: Pull up the button.
- 🔒** Press the button to lock the rear electric windows.

If the driver's side door and the front passenger's side door are not opened within a few minutes after the ignition switch is turned off, the electric windows can still be operated by buttons.

Single touch open and close function

The single touch open and close function enables an electric window to be fully opened or closed at once, without constantly manipulating the corresponding electric window button.

Single touch closing: Pull the corresponding electric window button up to the second gear position quickly and release the button to completely close the door and window.

Single touch open: Press the corresponding electric window button to the second gear position quickly and then release the button to completely open the door and window.

To terminate the single touch function: Then press or pull the corresponding electric window button to terminate the single touch function.

Easy closing

When the ignition switch is off, the doors and Windows can be closed outside the car with the vehicle key:

- Press the lock button on the vehicle key to close all electric windows at the same time.
- To stop the function, release the lock button.

For this purpose, a valid vehicle key must be available within vehicle access range. When all electric windows are closed, all turn signals are flashed *once* as confirmation.

WARNING

Improper or negligent use of electric windows may seriously injure people.

- When opening or closing doors and windows, ensure that no one is within the range of the glass.
- Do not leave children or people in need of assistance alone in a locked vehicle as they may not be able to open doors and windows by themselves in case of emergency.
- Always take all vehicle keys with you when you leave the vehicle.
- Children sitting in the rear seat when driving with the car must use the safety button to close the rear electric windows lifting function, so that the door and window can not be opened or closed.

NOTICE

- When electric windows are open, sudden rain may wet the equipment inside the vehicle and cause damage to the vehicle.
- When installing extra protective film for windows and doors, do not let liquid enter the dry area of the car and wet the electronic control unit. Otherwise, the electronic control unit will fail and the electric windows cannot be lifted.

 After the failure of electric windows, the single-touch opening and closing function and the roll-back function do not work. In this case, the system should be repaired at the qualified workshop as soon as possible.

 Convenience opening and closing works only when one-touch opening and closing is activated for all electric windows.

Windows roll-back function

Electric windows with roll-back function, it can effectively prevent the window glass hurt the occupant when closing the windows.



If a door or window is delayed or blocked when it automatically rises (closes), the single-touch closing function of the door and window will stop working immediately, and the window and window glass will automatically fall and open → .

- In this case, we should find out the reason why the doors and windows cannot be closed smoothly.
- Then try closing the doors and Windows again.
- If the closing process of doors and windows is interrupted again, the roll-back function will be disabled for a few seconds.
- If the door and window cannot be closed, the window and window glass will stop at the blocked position. If you pull up the button again within a few seconds, **the windows will be closed without roll-back function** → .

WARNING

Closing electric windows without roll-back function may hurt people inside the car.

- Be careful when closing doors and Windows.
- When closing doors and windows, make sure that no one is within the lifting range of windows and doors glass, especially when the roll-back function does not work.
- Roll-back function can not protect the fingers or other parts of the body at the window frame, beware of clamping!

 The roll-back function also works when using the vehicle key to close doors with Easy closing. 

Troubleshooting

Single touch open and close function is disabled

If the 12-volt vehicle battery is disconnected or the battery runs out when the windows are not completely closed, the single-touch function will not work. You must restore the single-touch function in the following ways. 

- Switch on the ignition.
- Close all windows and doors.
- Pull up the button on the corresponding window and hold it there for a few seconds.
- Release the button, then pull the button up again and hold it in the pull-up position. At this point, the single touch open and close function is restored.

You can use the method described above to restore the single touch function of a window or several windows at the same time.

Close the windows without Roll-back function

- Try to close the window again by holding the button for a few seconds. **At this time, the system for a small section of window glass path to close the roll-back function!**
- If the closing process lasts more than a few seconds, the roll-back function reactivates. If the window rises again or is blocked at another place, the window will stop closing again and automatically reopen.
- If the windows still cannot be closed, the system should be repaired at the qualified workshop as soon as possible.

Electric panoramic sliding/tilting roof

Opening and closing the glass roof

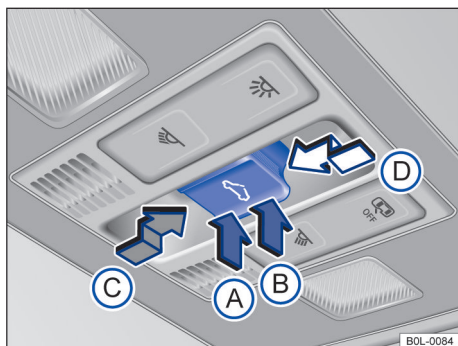



Fig. 52 In the roof: button for the glass roof

The glass roof is a roof opening system featuring two glass elements. The rear glass element is fixed in place and cannot be opened.

The button  has two positions. **First position:** Fully or partially tilt, open or close the roof. **Second position:** Automatically move the roof to the respective limit position. Press the button again to stop the automatic operation.

Opening and closing the glass roof

- *Tilting the glass roof:* Push button → Fig. 52 (B) to the first position. Automatic operation: push button (B) to the second position.
- *Closing the tilted glass roof:* Push button (A) to the first position. Automatic operation: push button (A) to the second position.
- *Opening the glass roof:* Push button (C) to the first position. Automatic operation to a convenience position: push button (C) to the second position.
- *Closing the tilted glass roof:* Push button (D) to the first position. Automatic operation: Push button (D) to the second position.
- *To terminate the autorun on or off process:* Press the button (C) or (D) again.

WARNING

Careless or unsupervised use of the glass roof can cause serious or fatal injuries.

- Open or close the glass roof only when there is no-one in the operating path of the roof.
- Always take all vehicle keys with you when you leave the vehicle.
- Never leave children or people in need of assistance alone in a vehicle, especially do not allow them access to the vehicle keys. Mishandling a vehicle key can lock the vehicle, start the engine, switch on the ignition and control the sunroof.
- Please note that the glass roof can still be opened or closed for a short time after the ignition has been switched off, provided that the driver door or front passenger door is not opened.

NOTICE

- At winter temperatures, always clear ice and snow from the vehicle roof before using the glass roof.

- Always close the glass roof when you leave the vehicle or if it starts to rain or snow. Otherwise, rain may flow into the vehicle through the open sunroof, seriously damaging the vehicle electrical system and other components.

 Remove leaves and other loose items from the glass roof guide rails at regular intervals using a vacuum cleaner or by hand.

 The roll-back function will not work properly if there is a fault with the glass roof. In this case, the sunroof should be repaired at the qualified workshop as soon as possible.

Functions of glass roof

Convenience opening and closing

The glass roof can be opened and closed from outside the vehicle using the vehicle key:

- Press and hold the locking or unlocking button on the vehicle key.
- Release the locking or unlocking button to interrupt this function.



Convenience closing closes all windows in the doors and the glass roof. After all windows and the glass roof have been closed, all turn signals will flash *once* as confirmation.

Glass roof roll-back function

The roll-back function prevents personnel from being hurt by the sunroof → . If the glass roof is impeded during the closing process, it will open again automatically.

- In this case, find out the reason why the sunroof cannot be closed smoothly as soon as possible.
- Then try again to close the sunroof.
- If the sunroof movement is still blocked and cannot be closed, close the sunroof without the roll-back function.

Closing the glass roof without the roll-back function

- Push the button  to the second position  until the glass roof has fully closed.
- **Close the glass roof without the roll-back function.**
- If you still cannot close the sunroof, you should go to the qualified workshop to repair the sunroof as soon as possible.

If you release the switch during the closing process, the sunroof will open automatically.

WARNING

Closing the glass roof without the roll-back function can cause serious or fatal injuries.

- Always take care when closing the glass roof!
- When closing the sunroof, ensure that no one is within the working range of the sunroof, especially when the roll-back function does not work.
- Roll-back function can not protect fingers or other parts of the body at the sunroof window frame, beware of clamping!

 The roll-back function is also activated if you use the convenience closing function on the vehicle key to close the windows and the glass roof.

Troubleshooting

- The glass roof only works when the ignition is switched on. The glass roof can still be opened or closed for a short time after the ignition has been switched off, provided that the driver door or front passenger door is not opened.
- It is not possible to close the glass roof electrically, it must be closed manually. The glass roof cannot be closed manually without removing vehicle components. Go to an authorized dealership for repair. Volkswagen recommends using a Volkswagen dealership.

Steering wheel

Adjusting the steering wheel position

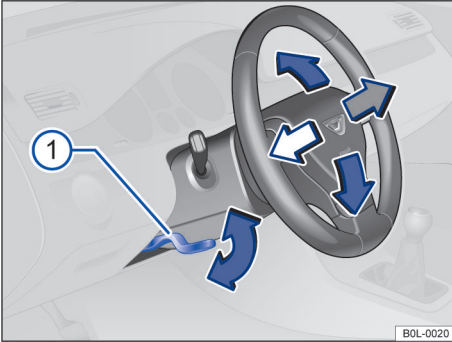

Fig. 53 On the steering column trim plate under the steering wheel: Control handle for mechanically adjusting the position of the steering wheel

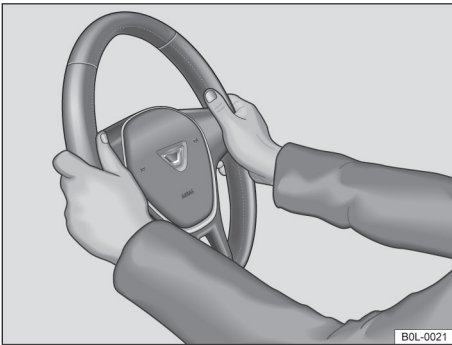

Fig. 54 On the steering wheel: 9 o'clock and 3 o'clock positions

Only before **starting to drive** and when the vehicle is completely stopped, the position of the steering wheel can be adjusted → ▲.

- Push down handle → Fig. 53 ①.
- Adjust the steering wheel to the appropriate position, the driver slightly bent elbow can be held in the steering wheel rim at the *Nine o'clock and three o'clock positions* → Fig. 54.
- Push the handle up until it is flush with the steering column → ▲.

⚠ WARNING

Improper steering column adjustment method and steering wheel adjustment error may cause serious casualties!

- After adjusting the steering column, be sure to push the handle → Fig. 53 ① up to lock it to prevent the steering column from shifting by itself during running.
- Do not adjust the steering wheel while the vehicle is moving. If you have confirmed that you need to adjust the steering wheel, you must stop the car, stop the car with caution, and then adjust the steering wheel to the correct position.
- The steering wheel must be facing the driver's chest, never his face. In the event of an accident, the airbag provides maximum protection for the driver.
- When driving, the driver must always keep both hands on the steering wheel rim at the *Nine o'clock and three o'clock positions* → Fig. 54 to reduce the degree of injury to the driver when the driver's front airbag is triggered.
- Never grip the steering wheel at the 12 o'clock position or in any other way (for example, between or on the inside of the steering wheel). Otherwise, if the driver's frontal airbag is triggered in an accident, the driver's arms, hands and head may be seriously injured.

Seats and head restraints

Front seats

Introduction

This chapter contains information on the following subjects:

- Mechanically adjusting the front seat 66
- Electrically adjustable front seat 67

The following section describes how to adjust the front seat. Make sure you're sitting correctly → page 28.

WARNING

Ensure that the seat, seat belt and head restraints are adjusted to the correct position before driving, and urge all occupants to fasten their seat belts.

- The front passenger seat should be moved back as far as possible.
- Adjust the driver's seat to ensure a minimum distance of 25cm between the chest and the wheel hub. Adjust the front and rear positions of the driver's seat so that the driver can fully press the pedal to the bottom with a slight bend of the knee, and the distance between the dash panel and the knee area should be at least 10cm. If you cannot meet the above requirements due to physical reasons, you can contact the company's dealer, who can modify the seat as necessary.
- The backrest must not lean too far back when the vehicle is running! Leaning on the backrest of the Angle is bound to cause front seat belt personnel wearing improper and sitting posture, accident more prone to injury.
- The backrest of the vehicle must not lean forward too much! When an airbag is triggered in an accident, it may strike the front seat backrest with force, causing it to move backwards and injure the occupant of the rear seat.
- The front passenger should be as far away from the steering wheel and dash panel as possible.

- When the vehicle is running, the front passenger must sit upright with the back close to the adjusted seat backrest and keep any part of the body away from the airbag installation position.
- Passengers in the rear seat are more likely to be seriously injured if they are not sitting properly due to improper seat belt wearing.

WARNING

Improper seat adjustment can cause an accident, serious injury!

- Adjust the front seat only when the vehicle is in a stopped state. If the seat is adjusted while driving, the seat may shift suddenly, causing the vehicle to lose control, which is very easy to cause accidents. In addition, if the front seat is adjusted when the vehicle is driving, the front seat personnel can not maintain the correct sitting posture, which is more likely to cause accidents.
- Seat height, front and back position and backrest tilt can be adjusted only when there are no obstacles in the area around the seat.
- Do not place anything in the front seat adjustment area.
- Only when no one is in the adjustment range of the seat, the backrest tilt and front and rear position of the front seat can be adjusted.
- Seat adjustment and locking area shall not be dirty.

WARNING

Improper use of seat covers or protective covers may result in inadvertent operation of the electric seat adjustment device and accidental adjustment of the front seat during driving. So the vehicle may be out of control. This can lead to accidents and injuries. In addition, it may also lead to property damage to the electrical components of the front seats.

- Seat covers or protective covers shall not be installed or fixed on electrically operated components.
- Only seat covers or protective covers expressly permitted for use in the vehicle may be fitted.

⚠ WARNING

Do not leave lighters and other inflammable and explosive products on the moving track/range of the electric seat. If the electric seat is squeezed into such items during the movement process, it may cause explosion or even fire and other accidents, seriously injuring drivers and passengers!

- Do not place lighters and other flammable and explosive products in the car storage space, boxes or other objects on the surface, especially in summer, the high temperature in the car may cause the lighter to spontaneously ignite.

⚠ WARNING

Only seat covers and shrouds that are expressly permitted for the vehicle by us are permitted. The seat cover and guard should not block or press the electric seat adjustment mechanism; otherwise, the front seat may move unexpectedly due to inadvertent misoperation of the electric seat adjustment during driving, which may result in vehicle loss of control and accidents resulting in injuries; It may also cause damage to the seat electric adjustment system due to the misoperation of the seat electric adjustment mechanism for a long time.

ⓘ NOTICE

Sharp edges can damage the seat.

- Keep sharp objects away from the seat. Sharp objects, such as zippers, rivets or belts on clothing, can damage the surface of the seat. Open Velcro straps can also cause seat damage.

Mechanically adjusting the front seat

📖 Please refer to ⚠ and ⓘ at the start of the chapter on page 65.

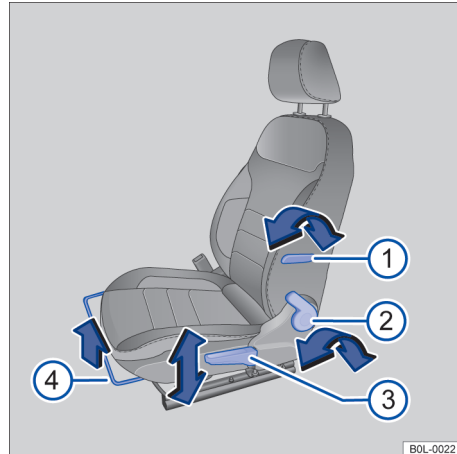

Fig. 55 On the left front seat: Operating element

The following sections describe all possible adjustment mechanisms. The number of adjusting mechanisms depends on the seat model.

The right front seat adjusting mechanism is arranged symmetrically with it.

Some front seats may be equipped with a combined mechanical/electric adjustment mechanism.

Adjust sitting position

Fig. 55 jump leads:

- ① The lumbar support can be adjusted by operating the rod.
- ② *Forward fold:* Pull the rod and flip the seat backrest forward.
To adjust the seat backrest: relieve the pressure on the backrest and turn the handwheel. The seat backrest must be stuck in a vertical position.
- ③ The seat height can be adjusted by lifting or lowering the handle several times as required.
- ④ Lift the rod while moving the front seat back and forth. The front seat must be locked after releasing the tie rod.

Electrically adjustable front seat

📖 Please refer to ⚠️ and ⓘ at the start of the chapter on page 65.

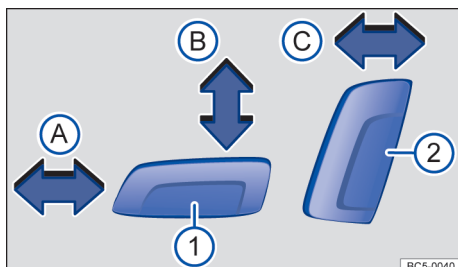

Fig. 56 Adjustment switch on the left front seat: adjust the seat position, backrest Angle and cushion height

Some front seats may be equipped with a combined mechanical/electric adjustment mechanism.

Adjust sitting position

Press the switch → Fig. 56 in the direction of the arrow:

- ① Ⓐ Move the seat back and forth.
- Ⓑ Raise or lower the seat.
- ② Ⓒ Adjust the Angle of the backrest.

⚠️ WARNING

Improper or negligent use of electric front seats can result in serious injury.

- The electric front seat adjustment mechanism still works when the ignition switch is off. Never leave children or people in need of assistance alone in the vehicle.
- In case of emergency, press another switch to terminate the electric adjustment process.

ⓘ NOTICE

To avoid damaging electrical components in the front seat, do not kneel on the seat or apply pressure to the seat cushion and backrest at any point.

ⓘ When the 12-volt vehicle battery is low, it may not be possible to adjust the front seat electrically.

ⓘ The system will temporarily interrupt seat adjustment when starting the engine. <

Rear seats

📖 Introduction

This chapter contains information on the following subjects:

- Folding forwards and backwards the rear seat backrest

68

The following section describes how to adjust the rear seat. Make sure you're sitting correctly → page 28.

⚠️ WARNING

Improper rear seat adjustment may result in accidents and serious injuries.

- The rear seat can be adjusted when the vehicle is in the stopped state. If the seat is adjusted while driving, the seat may shift suddenly; And in the adjustment of the seat, the rear personnel can not maintain the correct sitting posture, easy to cause accidents.
- The risk of serious injury increases if the rear occupant is unable to sit properly due to incorrect seat belt insertion.
- Only when no one is in the adjustment range of the rear seat, the seat can be adjusted.

⚠️ WARNING

If flammable and explosive materials such as lighters are left behind in the vehicle, they may be damaged or ignite undetected, and may seriously burn people and damage the vehicle.

- Each time before closing storage space or storage boxes, ensure that there are no lighters and other flammable and explosive materials in the closed area.
- Do not place lighters and other flammable and explosive products in the car storage space, boxes or other objects on the surface, especially in summer, the high temperature in the car may cause the lighter to spontaneously ignite.

⚠️ WARNING

To reduce the risk of injury, the rear centre armrest must always be folded up while the vehicle is in motion and the stowage compartment must be closed. ▶

- The centre seat on the rear bench seat must never be used when the centre armrest is folded down – neither by adults nor children. An incorrect sitting position can cause serious injury.
- The centre seat on the rear bench seat must never be used when the centre armrest is folded down – neither by adults nor children.
- The stowage compartment can be closed only when there is no person within the flipping range of the centre armrest.

NOTICE

Sharp edges can damage the seat.

- Keep sharp objects away from the seat. Sharp objects, such as zippers, rivets or belts on clothing, can damage the surface of the seat. Open Velcro straps can also cause seat damage.

Folding forwards and backwards the rear seat backrest

Please refer to ▲ and ❶ at the start of the chapter on page 67.

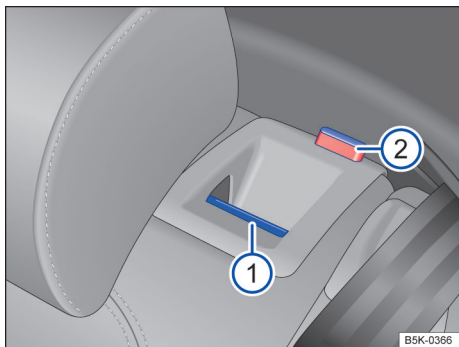

Fig. 57 In the rear seat backrest: Unlock button

The rear seat backrest is a split backrest, and the two backrests can be folded forward respectively to expand the suitcase capacity.

Fold the rear seat backrest forward

- Press the head restraints down completely.
- Then move the head restraints up one slot.
- Pull the release button forward → Fig. 57 ❶ while folding the seat backrest forward.

If you can see red mark ❷ on the button, it indicates that the corresponding seat backrest has been unlocked.

Flip back to the rear seat backrest

- Turn the rear seat backrest to its original position and push back hard until you hear it lock → ▲.
- Check that the rear seat backrests are fully locked.
- The red mark ❷ on the button should not be visible after the backrest is locked.

WARNING

Be careful when folding and turning back the back seat backrest to avoid injury due to negligence!

- When folding the back seat backrest, no one is allowed within the fold range of the back seat.
- Do not bend forward or turn back the rear seatrest back while driving.
- Be careful not to clip or damage the seat belt when folding the rear seat backrest.
- Do not place your hands, fingers or other parts of your body in the seat folding area when folding the backrest of the rear seat.
- Both rear seat backrests must be fully locked. If not locked, the rear seat belts may not work properly, especially the rear middle seat belts. If the rear seat is occupied but the rear seat backrest is not locked, the occupant and the seat backrest will move forward together in case of emergency braking or rapid acceleration or in case of an accident.
- No person (including adults and children) shall occupy the rear seat which has been folded forward and the back seat backrest is not fully locked.

NOTICE

Be careful when folding and turning back the rear seat backrest to avoid damage to the contents of the car due to negligence or loss of control.

- In order to avoid the rear seat cushion and head restraints scratching the front seat backrest, the front seat should be adjusted to the appropriate position before the front folding rear seat backrest.

- Before folding the rear seat backrest, ensure that there is no object within the reversing range of the rear seat backrest.

Head restraints

Introduction

This chapter contains information on the following subjects:

- Adjusting the head restraints 70
- Head restraints removing and installing 70

The following sections describe how to adjust and remove the head restraints. Make sure you're sitting correctly → page 28.

The car seats are equipped with head restraints. The rear seat centre head restraints is designed for the rear seat centre, so the head restraints cannot be installed on other seats.

There are bayonets in the support rod of the head restraints, so the head restraints can be stuck in different positions. Only properly installed head restraints can be clamped on bayonets in the setting range. To prevent incorrect removal of the head restraints after assembly, a stop is provided above and below the adjustment range.

The correct position of the head restraints

Adjust the head restraints so that the upper edge of the head restraints is equal to the top of the head, but not lower than the eyes. The back of the head should be as close to the head restraints as possible when the vehicle is driving.

Short occupant head restraints adjustment method

Small passengers should press the head restraints down to the lowest clamping position when adjusting the head restraints. Even so, the top of the passenger's head may still be lower than the upper edge of the head restraints. There may still be a gap between the head restraints and the top of the backrest when the head restraints is in the lowest position.

Tall occupant head restraints adjustment method

- ◁ When adjusting the head restraints, tall passengers should lift head restraints to limit position as far as possible.

WARNING

If the vehicle in the removal of head restraints or head restraints installation/adjustment of the case of improper driving, once an accident or rapid acceleration or emergency braking is easy to cause serious casualties!

- The head restraints must be installed in the car seat, and the head restraints should be adjusted correctly.
- All drivers and passengers must adjust the head restraints to their body shape to avoid neck injury due to accidents. The upper edge of the head restraints must be as high as possible above the occupant's head, but not lower than the eyes. The back of the head should be as close to the head restraints as possible while driving.
- Do not adjust the head restraints while the vehicle is moving.

NOTICE

When removing and assembling the head restraints, be sure not to collide with the roof or other parts of the car. Otherwise, the roof or other parts of the car may be damaged. ▷

Adjusting the head restraints

📖 Please refer to ▲ and ① at the start of the chapter on page 69.

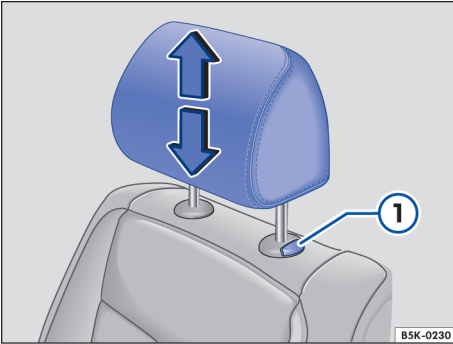

Fig. 58 Adjust the front seat head restraints

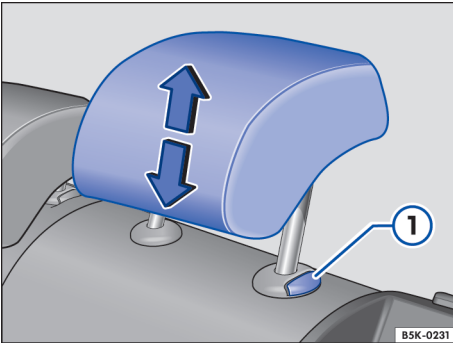

Fig. 59 Adjust the rear seat head restraints

Adjust seat head restraints height

- Push the head restraints up or down in the direction of the arrow, holding the buttons → Fig. 58 ① or → Fig. 59 ② if necessary → ▲ in *Introduction* on page 69.

After adjustment, the head restraints must be stuck in place.

Head restraints removing and installing

📖 Please refer to ▲ and ① at the start of the chapter on page 69.

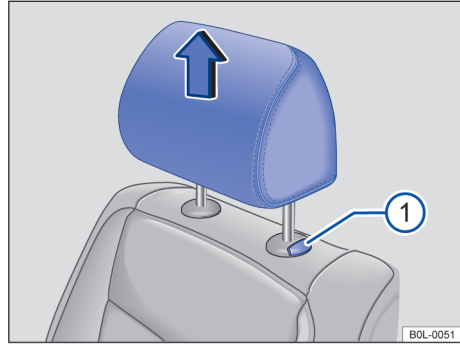

Fig. 60 Remove front seat head restraints

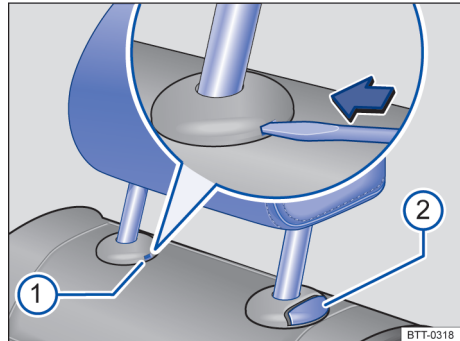

Fig. 61 Remove rear seat head restraints

Remove front seat head restraints

- Adjust the seat backrest if necessary to remove the head restraints → page 65.
- Pull the head restraints up to stop position → ▲ in *Introduction* on page 69.
- Press button → Fig. 60 ① while pulling the head restraints out completely. ▶

Install the front seat head restraints

- Align the head restraints guide bar with the catheter on the corresponding seat back and insert it into the catheter.
- Press button → Fig. 60① and push down the headrests.
- After installation, adjust the head restraints to the correct position according to your body type → page 28.

Remove rear seat head restraints

- Unlock the rear seat backrest and flip it slightly forward → page 65.
- Push head restraints up into stop position → ⚠ in *Introduction* on page 69.
- Insert the open vehicle key head or screwdriver cutter head into the slot of the sheath → Fig. 61①.
- Use the car key or screwdriver to hold the unlocking device in the direction of the arrow.
- Press button → Fig. 61② at the same time, and another person will pull the head restraints out completely.
- Push the backrest back in place to lock it.

Install the rear seat head restraints

- Unlock the rear seat backrest and flip it slightly forward.
- Align the head restraints with the head restraints guide and insert it into the guide.
- Press and hold button → Fig. 61② while pushing down the head restraints.
- Push the backrest back in place to lock it.
- After installation, adjust the head restraints to the correct position according to your body type → page 28.

Seat functions

Seat centre armrest

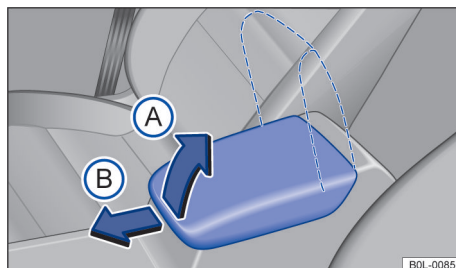

Fig. 62 Front seat centre armrest

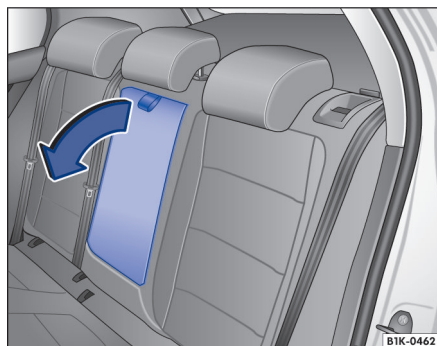

Fig. 63 Rear fold-out centre armrest

Adjust the front centre armrest

If needed *To fold back*: fold the centre armrest upwards in the opposite direction of the arrow → Fig. 62 A and push it into the backrest as far as it will go.

◀ If needed *To fold down*: pull the loop on the centre armrest in the direction of the arrow.

If needed *To adjust* the positions of the centre armrest, push the armrest forward along the direction of B, or push backwards if it is stuck. ▶

Rear fold-out centre armrest

- There may be a fold-out centre armrest in the backrest of the middle seat of the rear bench seat.
- *To fold down:* pull the loop on the centre armrest → Fig. 63 in the direction of the arrow
- *To fold back:* fold the centre armrest upwards in the opposite direction of the arrow → Fig. 63 and push it into the seat back.

⚠ WARNING

The front centre armrest may interfere with the driver's arm movement and could cause an accident that could seriously injure someone.

- The storage box in the front armrest must be closed at all times while the vehicle is in motion.
- No one shall sit on the centre armrest while the vehicle is moving! Otherwise, serious injury is very likely.

⚠ WARNING

To reduce the risk of injury, the rear centre armrest must always be folded up while the vehicle is in motion.

- The centre seat on the rear bench seat must never be used when the centre armrest is folded down – neither by adults nor children. An incorrect sitting position can cause serious injury.

Lights

Turn signals

Switching turn signals on and off

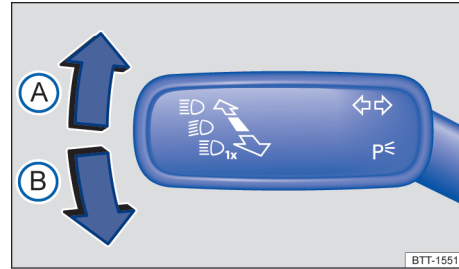

Fig. 64 Left side of steering column: turn signals/headlight main beam lever

- Switch on the ignition.
- Move the turn signals/headlight main beam lever → Fig. 64 from the middle position to the following position:

- A** Turn signals on the right ➔.
- B** Turn signals on the left ➜.

- Switch off the turn signals by turning the turn signals/headlight main beam lever back to the middle position.

If there is no sound signal when turning on the turn signals, please go to the qualified workshop for repair.

Lane change flash function

To switch on the lane change flash function, turn the lever up or down to the resistance point, then release the lever, and the turn signals flashes three times

At this time, if the turn signals/headlamp main beam lever is directly shifted to the resistance point in the opposite direction and released, you can exit the lane change flash function in advance.

⚠ WARNING

Improper use of the turn signals, not using the turn signals or forgetting to switch off the turn signals may mislead other road users, which is very likely to cause serious injuries and deaths!

- Always switch on your turn signals when changing lanes, overtaking, or turning.
- Switch off the turn signals immediately after changing lanes, overtaking or turning.

i The hazard warning light will still work after the ignition switch is turned off → page 49. <

☞☞ Side lights or permanent parking lights on both sides have been turned on → page 75, and the symbol in the switch of lights has turned green.

☞ Headlight dipped beam off - If the vehicle key is still in the ignition or the driver's door is closed in a vehicle equipped with Keyless Access, the side lights remains on.

Vehicle lighting

Switching lights on and off



Fig. 65 Beside the steering wheel: Light switch (this type is only an example)

Switch on the headlights

- Switch on the ignition.
- Turn the light switch to the corresponding position:

AUTO Automatic control of headlamp dipped beam: Switch on or off dipped beam according to brightness and weather conditions → **▲**.

☞☞ The side lights are on. The symbol in the light switch turns green.

☞ The headlight dipped beam is on.

Switch off the headlights

- Switch off the ignition.
- Turn the light switch to the corresponding position:

O The headlights are off.

AUTO "Leave home" function (directional lighting) can be enabled → page 76.

Daytime running light

Depending on the vehicle type, daytime running lights can improve the visibility of a vehicle in road traffic during the day.

The daytime running lights are switched on every time the ignition is switched on when the light switch is in position **O** or **AUTO**, (if brightness is detected)

Daytime running lights cannot be turned on or off manually.

▲ WARNING

Accidents and serious injuries may occur when the road is not adequately lit and the vehicle cannot or is difficult to detect by other traffic participants.

- Drivers must ensure that vehicle lighting is properly turned on so that the light assist system can support driving.
- Always switch on the headlamp dipped beam in darkness, rain and poor visibility.
- Regularly check that all lights and turn signals are working properly.

▲ WARNING

Side lights or daytime running lights are not bright enough to fully illuminate the road and allow other traffic participants to see the vehicle.

- Always switch on the headlamp dipped beam in darkness, rain and poor visibility.
- The taillights will not be turned on at the same time when the daytime running lights are turned on. Vehicles with unturned taillights cannot be seen by other traffic participants in darkness, precipitation, and poor visibility. ▶



WARNING

The automatic headlamp dipped beam control (**AUTO**) function turns the headlamp dipped beam on and off only when the ambient brightness changes.

- In special weather conditions (such as foggy days), switch on the headlamp dipped beam manually.

Turn fog lights on and off

The rear fog light can be switched on when the ignition is switched on and when the light switch is in the **AUTO** and dipped beam positions: 

- **Switch on the rear fog lamp** : Pull the light switch up to stop. The indicator lamp  lights up yellow in the instrument cluster.
- Press in the light switch or turn to position **0**.

 If the rear fog light is switched on **AUTO** while the automatic headlight control is switched on, the dipped beam headlights will also be switched on irrespective of the prevailing light conditions outside.

Lights functions

Side lights

If the side lights  is turned on, the side lights in the headlight on both sides, the local area of the taillight, the license plate light, the centre console button and the dash panel button are lit.

Any **not** locking the vehicle from the outside, and about 10 minutes later, the parking side lights will be automatically switched to the permanent parking light on both sides to reduce the load of the 12-volt on-board battery → page 75.



Headlight auto control **AUTO**

If the headlight auto control **AUTO** has been switched on, the vehicle lighting and instrument and switch lighting will automatically switch on and off according to the ambient light. If the headlight is turned on, the indicator light will light yellow.

The headlight automatic control function is only an auxiliary function, it is impossible to fully identify all the driving environment of the vehicle.

Warning sound when headlights are not turned off

When the vehicle key is removed from the ignition and the driver's door is opened, the system will sound a warning tone when:

- When the parking lights are on.
- When the side lights  or rear fog lamp  are on.

When the “Coming homing” function is enabled, the system will not trigger a signal tone when the driver's side door is opened, indicating that a certain headlight is still on.

Troubleshooting

Turn signals indicators

If one side of the turn signals is disabled, the flashing frequency of the corresponding side of the turn signals indicators will be doubled.

The indicators shine green.

- Check vehicle lighting and replace appropriate bulbs if necessary. → page 155
- If the fault persists, go to a correspondingly qualified workshop. Volkswagen recommends using a Volkswagen dealership.

Running light fails

Service lights are partially or completely faulty.

The indicator lamp lights up.

- Check vehicle lighting and replace appropriate bulbs if necessary. → page 155
- If the fault persists, go to a correspondingly qualified workshop. Volkswagen recommends using a Volkswagen dealership.

Headlight main beam

Switching headlight main beam on and off

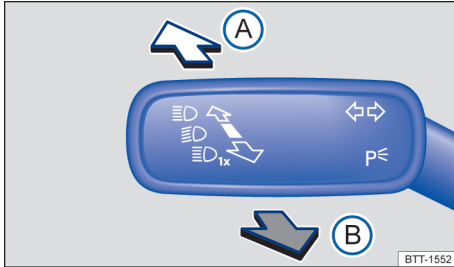



Fig. 66 Left side of steering column: turn signals/headlight main beam lever

- Switch on the ignition and the headlight dipped beam.
- Move the turn signals/headlight main beam lever from the middle position to the following position:

- A** Switch on the headlight main beam.
- B** Operate the headlight flasher or switch off the headlight main beam. Pull the lever in this position *and headlight flasher* is in working condition.

Switch on the headlamp main beam or operate the headlamp flasher, the blue indicator  in the instrument cluster lights up.

WARNING

Improper use of headlamp main beam may cause accidents, resulting in injuries! Because it may have a blinding effect on the drivers of other vehicles, making them unable to concentrate.

Parking light

Switching parking lights on and off

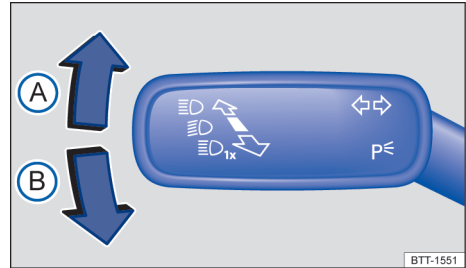

Fig. 67 Left side of steering column: turn signals/headlight main beam lever

Switch on the single parking light

When the parking light is turned on, the side lights on the corresponding side of the vehicle, the taillight and part of the tail light clusters are lit at the same time:

- Switch off the ignition.
- Position the turn signals/main beam lever from the middle position in the following position:

- A** Switch on the right parking light.
- B** Switch on the left parking light.

Switching permanent parking lights of both sides on

When the permanent parking lights on both sides are turned on, the side lights at the front and the local area of the taillight are lit up.

- Switch on the ignition and rotate the light switch into position .
- Switch off the ignition.
- Lock the vehicle from the outside.

Parking side lights and parking light Auto Off function

If the battery power is insufficient to keep the side lights or parking light on for 2 hours, the system will not automatically switch off the side lights or parking light. At this point, the side lights or parking light will be lit until the battery is completely exhausted. You can't start the engine again → .

If the parking time is more than two hours, the system will recognize that the 12-volt battery is low and switch off the side lights or parking lights to ensure that the engine can still start.

⚠ WARNING

A vehicle parked without adequate lighting may make it impossible or difficult for other traffic participants to detect the vehicle and may result in an accident and serious injury.

- Be sure to stop the vehicle safely and ensure adequate lighting, in accordance with country-specific laws and regulations.
- If you need to use the outside lighting for a long time, switch on the right or left parking lights as far as possible. This is because the lighting time of unilateral parking lights is usually twice as long as that of permanent parking lights on both sides.

"Coming home" and "Leaving home" function (directional lighting)

"Coming home" and "Leaving home" can illuminate the area around the vehicle when light is low during departure and boarding.

Switching on the "Coming Home" function

When the light switch is in position **AUTO** and the rain/light sensor recognizes *low light*, "Coming home" function is enabled.

"Coming home" is automatically enabled when opening the driver door. When the last door or tailgate is closed, the timer for "Lights Delay Off" starts *counting*.

Disable the "Coming home" function

- After the "Delay Lights Off" timing ends, the light will automatically switch off.
- **Or:** When one door or taildoor is still open about 30 seconds after "Coming home" function is enabled, the light will automatically switch off.
- **Or:** Turn the light switch to position. **0**

Enable the "Leaving home" function

- When the light switch is in position **AUTO** and the rain/light sensor recognizes *dark environment*, the light will switch on automatically when unlocking the vehicle.

Disable the "Leaving home" function

- After the "Delay Lights Off" timing ends, the light will automatically switch off.
- **Or:** Lock the vehicle.
- **Or:** Turn the light switch to position. **0**

Ambient light in the outside rearview mirror

Ambient lights in the rear view mirror directly illuminate the area around the door when getting on and off the vehicle. Switch on the ambient lights when you unlock the vehicle or activate the "Coming home" or "Leaving home" lighting functions. If the vehicle is equipped with a light sensor, the environmental lights in the rear view mirror will be turned on only when the sensor perceives the environmental darkness.

Headlights

Headlight range control

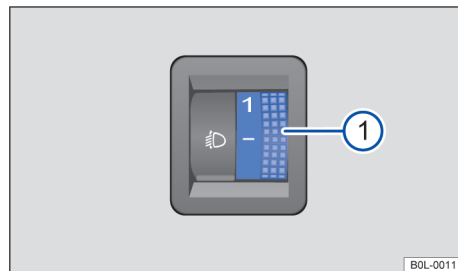

Fig. 68 Next to light switch: headlight range adjustment knob

Headlight range adjustment adjusts the headlight beam to the appropriate position according to the vehicle load, improving visibility without blinding oncoming traffic → ⚠

The headlamp lighting range can be adjusted only when the headlamp dipped beam is turned on. ▶

Headlamp lighting range adjustment

Rotate adjustment knob ① to the following position according to vehicle load:

Knob position	Vehicle load
—	Front seat taken, trunk empty.
1	All seats taken, trunk empty.
2	All seats are occupied, trunk is full. Towing a low load trailer.
3	Only the driver's seat is occupied and the trunk is full. Traction maximum load trailer.

WARNING

If the headlight is adjusted too high or the use of main beam is improper, it may have blinding effect on the drivers of other vehicles on the road, distracting their attention, which is very easy to cause serious casualties!

- Be sure to adjust the headlamp correctly so that it is always properly lit.
- Do not switch on headlight main beam or headlight flasher if it may cause blinding effect to other vehicle drivers.

WARNING

Heavy objects in the car may cause headlights to blinding other road users, distracting their attention and causing serious injuries and deaths!

- To avoid blinding effect on other road users, the headlight beam must be adjusted to the correct position according to the vehicle load.

Switch headlight when driving abroad (tour mode)

If a vehicle is travelling in a country or region passing on the left, the asymmetric headlight dipped beam may blinder oncoming traffic. Therefore, in order to eliminate the glare effect, it is necessary to paste or adjust the headlights.

Tape may be used to block a portion of the headlight glass or the headlight may be adjusted by the qualified workshop. Volkswagen dealership

can provide you with detailed information and this work should be carried out by the qualified workshop.

 The method of blocking and adjusting the headlight may only be used temporarily. Permanent changes to the headlight settings may be made by contacting Volkswagen dealership, who shall make permanent changes to the headlight settings.

Interior lighting

Instrument and switch lighting

When the light switch is in position **AUTO**, the sensor automatically detects the ambient brightness level and switches the dipped beam and the lighting in the instruments and switches on and off.

 When the lights are switched off and the ignition is switched on, the instrument and switching lighting (needles and scales) is switched on automatically. As the ambient light becomes lower, the lighting of the scales is automatically reduced and may be switched off entirely. This function is intended to remind the driver to switch on the dipped beam in good time, i.e. when driving through tunnels.

Interior and reading lights, background lighting

Press the corresponding button:



Switch on the interior lights.



Switch the reading light on or off.



Switch off the interior lights door control function.



Switch the reading light on or off.

Intermediate position

Interior lights door control function: the interior lights switch on automatically when the vehicle is unlocked, the doors are opened, or the vehicle key is removed from the ignition lock.

Luggage compartment lights

The internal lights will be switched on or off when the boot lid is opened or closed.

Background lighting

Depending on the equipment level, the background lighting provides indirect light in the various areas of the vehicle interior.

Other areas can also be illuminated, e.g. the footwell.

The brightness and colour of the background lighting can be adjusted in the **Vehicle settings** in the Infotainment.

 The lights switch off automatically when the vehicle is locked or a few minutes after the vehicle key is removed from the ignition lock. This prevents the 12-volt battery from discharging.

Vision

Wipers

Operating the wiper lever

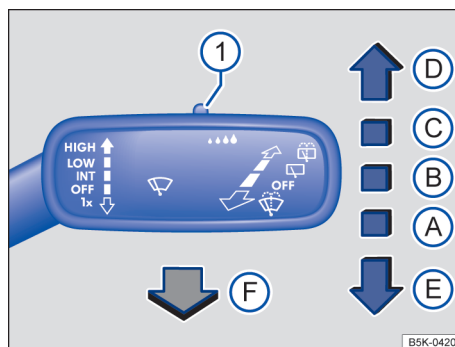

Fig. 69 On the right-hand side of the steering column: operating the windscreen wipers.

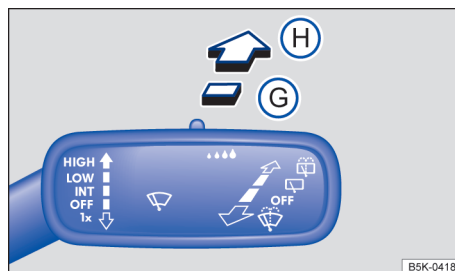

Fig. 70 On the right-hand side of the steering column: operating the rear windscreen wipers.

Depending on the equipment level, the wipers function only when the ignition is switched on and the bonnet or boot lid are closed.

Move the wiper lever to the desired position → ①:

- ① **OFF** The wipers are switched off.
- ② **INT** Interval wipe for the windscreen or rain sensor mode. The interval wipe for the windscreen depends on the speed of the vehicle. The wipers will wipe more frequently as the vehicle moves faster.
- ③ **LOW** Slow wiping.
- ④ **HIGH** Fast wiping.
- ⑤ **1x** Flick wipe – short wiping. Push and hold the lever down for longer to wipe more quickly.

- F Pulling the lever activates the automatic wipe/wash function for cleaning the windscreen. The Climatronic will switch to air recirculation mode for approximately 30 seconds to prevent the smell of the windscreen washer fluid from entering the vehicle interior.
- I Use the switch to adjust the wipe intervals (vehicles without a rain and light sensor) or the sensitivity of the rain and light sensor.
- G Interval wipe for the rear windscreen. The wipers wipe about every six seconds.
- H Pulling the lever activates the automatic wipe/wash function for cleaning the rear windscreen.

WARNING

Without adequate anti-freeze, the washer fluid may freeze onto the windscreen and obscure your view. This can cause accidents and serious or fatal injuries.

- At winter temperatures, use the window washer system only when adequate anti-freeze has been added.
- Never use the windscreen washer system at winter temperatures before the windscreen has been heated by the ventilation system.

WARNING

Worn or dirty windscreen wiper blades reduce visibility and increase the risk of accidents and severe injuries.

- Always change wiper blades if they are damaged or worn and no longer clean the windscreen properly → page 153

NOTICE

Before starting your journey and **switching on the ignition**, check the wipers carefully. Otherwise, it may lead to damage to the windscreen, wiper blades, or the wiper motor.

- Make sure that the wiper lever is in its basic position.
- Remove snow and ice from the wipers and windows.
- Always carefully loosen wiper blades that have become frozen onto the window. De-icing spray is recommended.

NOTICE

Do not switch on the wipers when the window is dry. Otherwise, the window may be damaged.

When switched on, the wipers will temporarily be switched to the next setting down when the vehicle is stationary.

If the vehicle is parked during cold weather, the service position of the windscreen wiper may be helpful in order to be able to release the wiper blades better from the windscreen → page 153

Wiper function

Automatic activation of the rear window wiper

The rear window wiper is switched on automatically when the windscreen wipers are switched on and reverse gear is engaged.

Rain and light sensor

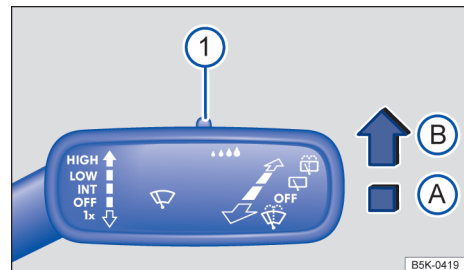

Fig. 71 On the right of the steering column: wiper lever.

When the rain and light sensor is activated, it automatically controls the frequency of the wiper intervals, depending on the intensity of the rain.

Activating and deactivating the rain and light sensor

Push the lever into the required position

→ Fig. 71:

- Position **(A)** - The rain and light sensor is deactivated.
- Position **(B)** - The rain and light sensor is activated, automatic wipe when necessary.

Adjusting the sensitivity of the rain and light sensor

The sensitivity of the rain and light sensor can be adjusted manually using the switch → Fig. 71 ① in the wiper lever → ▲.

- Switch to the right – high sensitivity.
- Switch to the left – low sensitivity.

The rain and light sensor remains active when the ignition is switched off and on again, and re-activates when the wiper levers are in position ② and the vehicle speed is higher than 16 km/h.

⚠ WARNING

The rain and light sensor cannot always detect all precipitation sufficiently and activate the wipers. If visibility is restricted, this can cause accidents and serious or fatal injuries.

- If necessary, switch on the wipers manually if the water on the windscreen restricts the field of vision.

- **Soiling:** dry dust, wax, windscreen coatings (lotus effect), or detergent deposits (from an automatic car wash) can cause the rain and light sensor to become less sensitive and react too slowly, or prevent it from reacting at all. Clean the sensitive surface of the rain and light sensor → page 206 at regular intervals and inspect the wiper blades for damage.
- **Crack in the windscreen:** a wipe cycle will be triggered if the rain and light sensor is switched on when the windscreen is impacted by a stone. The rain and light sensor will then register the reduction in sensitivity of the surfaces and adjust accordingly. The size of the crack can affect the way in which the rain and light sensor activates the wipers.

 The wipers will try to wipe away any obstacles that are on the window. The wipers will stop moving if the obstacle blocks their path. At this point, remove the obstacle and switch the wipers back on again. <

Troubleshooting

Fault in wipers

The wipers do not wipe.

- Switch the ignition off and on.
- If the fault persists, go to a correspondingly qualified workshop. Volkswagen recommends using a Volkswagen dealership.

Fault in rain and light sensor

Possible causes for faults and misinterpretations relating to *the sensitive surface* → page 5 of the rain and light sensor:

- **Damaged wiper blades:** a film of water or smears caused by damaged wiper blades can increase the time the wipers are switched on, can shorten the length of the intervals between wipes, or cause the wipers to run quickly and continuously.
- **Insects:** insects hitting the windscreen surface can cause the wipers to be activated.
- **Salt deposits:** in winter, salt deposits can cause the wipers to continue to wipe the windscreen when it is almost dry.

Mirrors

Introduction

This chapter contains information on the following subjects:

- Interior mirror 81
- Exterior mirrors 82

The driver can use the exterior mirrors and interior mirror to observe the traffic behind and adjust the driving style accordingly.

For safety reasons, it is important that the driver positions the exterior and interior mirrors correctly before starting a journey → ▲.

Looking in the exterior mirrors and the interior mirror does not allow the driver to see the entire area around the side and rear of the vehicle. The area that cannot be seen is known as the blind spot. There may be objects and other road users in the blind spot. ▶

⚠ WARNING

Adjusting the exterior and interior mirrors while driving may cause the driver to become distracted. This can cause accidents and serious or fatal injuries.

- Adjust the exterior mirrors and interior mirror only when the vehicle is stationary.
- When parking, changing lane, overtaking or turning, always pay careful attention to the area around the vehicle. There may be objects and other road users in these blind spots.
- Always ensure that the mirrors are positioned correctly and that the rear view is not restricted by ice, snow, condensation or any other objects.

⚠ WARNING

An inaccurate estimation of the distance from vehicles following behind can cause accidents and serious or fatal injuries.

- Curved mirrors (convex or spheric) enlarge the field of vision and can make objects in the mirror seem smaller and further away than they actually are.
- Using curved mirrors to estimate distance from other vehicles while changing lanes may cause serious injury or death.
- Whenever possible, use the interior mirror to check the exact distance between your vehicle and following traffic or other objects.
- Ensure that you have a good view to the rear of the vehicle.

⚠ WARNING

Automatic anti-dazzle mirrors contain an electrolyte fluid which could leak if the mirror is broken.

- Contact with this fluid can cause irritation to the skin, eyes and respiratory organs, especially in people who suffer from asthma or similar illnesses. In this case, immediately make sure that there is a sufficient supply of fresh air and get out of the vehicle or, if this is not possible, open all windows and doors.
- If your eyes or skin come into contact with the electrolyte fluid, wash the affected location immediately with plenty of water for at least 15 minutes and consult a doctor.

- If your shoes or clothing come into contact with the electrolyte fluid, wash them immediately with plenty of water for at least 15 minutes. Clean shoes and clothes thoroughly before wearing them again.
- If you have swallowed electrolyte fluid, rinse your mouth immediately with plenty of water for at least 15 minutes. Do not induce vomiting unless instructed to do so by a doctor. Seek medical assistance immediately.

ⓘ NOTICE

If the glass of an automatic anti-dazzle mirror is broken, electrolyte fluid can leak from the mirror. This fluid attacks plastic surfaces. Remove any fluid that has leaked out as soon as possible, e.g. with a wet sponge.

Interior mirror

📖 Please refer to **⚠** and **ⓘ** at the start of the chapter on page 81.

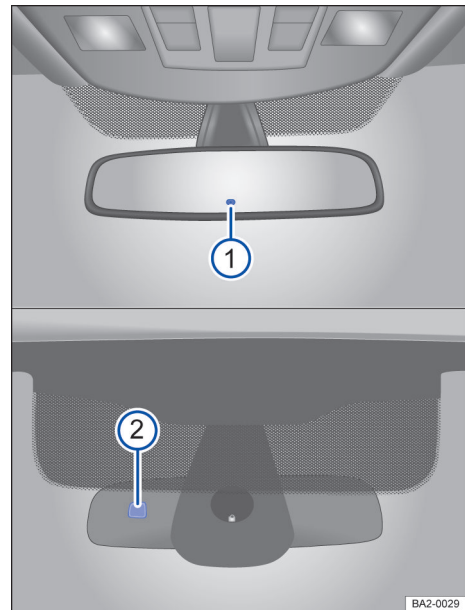

Fig. 72 On the windscreen: automatic anti-dazzle interior mirror

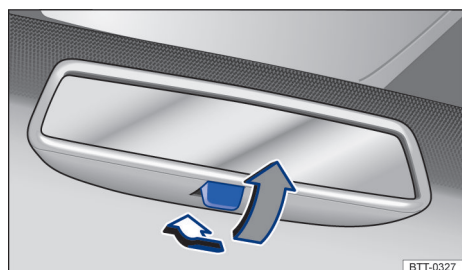

Fig. 73 On the windscreen: manual anti-dazzle interior mirror

The driver must adjust the interior mirror to an appropriate position so that the situation behind the vehicle can be seen clearly through the rear windscreen.

Automatic anti-dazzle interior mirror

When the ignition is switched on, the sensors measure the incident light from the rear → Fig. 72 ① and from the front ②.

Depending on the values measured, the interior mirror dims automatically.

If the incident light on the sensors is hindered or interrupted, e.g. by a sun blind or other hanging objects, the automatic anti-dazzle interior mirror will not function or will not function correctly. Mobile navigation devices attached to the windscreen or near the interior automatic anti-dazzle interior mirror can also influence the sensors. → ▲.

The automatic anti-dazzle function will be deactivated in some situations, e.g. when reverse gear is engaged.

Manual anti-dazzle interior mirror

- Basic position: the lever on the lower part of the mirror is pointing forwards towards the windscreen.
- Pull the lever back to select the anti-dazzle function → Fig. 73

▲ WARNING

The illuminated display of a mobile navigation system can interfere with operation of the automatic anti-dazzle interior mirror. This can result in accidents and serious or fatal injuries!

- As a result, the interior mirror cannot be used to check the exact distance between your vehicle and following traffic or other objects.

Exterior mirrors

📖 Please refer to ▲ and ① at the start of the chapter on page 81.

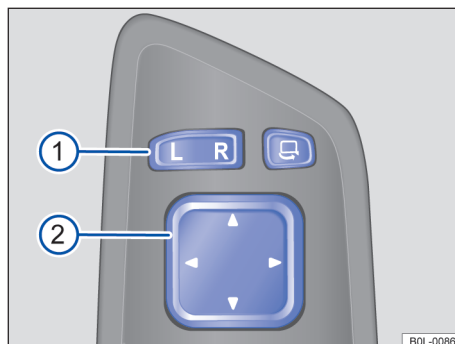

Fig. 74 In the driver door: operating elements for the exterior mirrors.

- Switch on the ignition.
- Press the button → Fig. 74 ① in the driver door to the desired position.
- To adjust the exterior mirror, press the button ② forward, back, right or left in the direction of the arrows.

- L** Adjust the left-hand exterior mirror.
- R** Adjust the right-hand exterior mirror.
- ▲ Flip up the mirror surface.
- ▼ Flip down the mirror surface.
- ◀ Left tilt the mirror surface.
- ▶ Adjust the right-hand exterior mirror.
- 🔄 Fold exterior mirrors into the body electrically → ▲.

When button ① is in the middle, the exterior mirrors cannot be adjusted.

▲ WARNING

Be careful when folding out or in the exterior mirrors to prevent injury.

- Fold the exterior mirrors in or out only when there is no obstruction in the path of the mirror.

- If the exterior mirrors are folded out or in without paying due attention, fingers can be trapped between the exterior mirror and the mirror base.

NOTICE

- Be sure to fold in the exterior mirrors when washing the vehicle in an automatic car washer.
- Do not fold electrically adjustable exterior mirrors in or out by hand. This can lead to damage the electric drive.

 The exterior mirror heating should be switched off when it is no longer needed. Fuel is otherwise wasted.

 If the electric exterior mirrors fail, manually adjust their position by pressing the outer edge of the mirror surface.

Protection from the sun

Sun visors

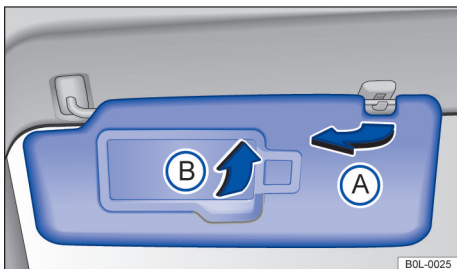

Fig. 75 In the front headliner: sun visor

Adjustment options for the driver and front passenger sun visors:

- Folded down over the windscreen.
- Pulled out of the bracket and swung over towards the door → Fig. 75(A).

Vanity mirror

There is a vanity mirror behind a cover → Fig. 75 (B) on the inside of the sun visor. Open the cover and you can see the vanity mirror.

WARNING

Driving with the sun visors folded down and the sun blinds pulled out can reduce your view of the road.

- Sun visors should always be folded away and sun blinds should always be retracted if they are not being used.

Sun blind in the glass roof

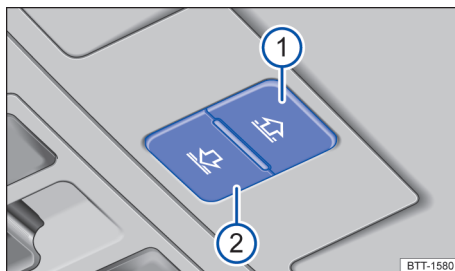

Fig. 76 In the roof: button for controlling the sun blind

The electric sun blind works when the ignition is switched on.

When the glass roof is fully tilted, the sun blind is automatically moved to a ventilation position. The sun blind remains in the ventilation position even when the glass roof is closed.

Opening and closing the sun blind

The buttons → Fig. 76 ① and ② have two positions. In the first position, the sun blind can be completely or partially opened or closed.

In the second position, the sun blind automatically moves to the final position when the button is operated briefly. Press the button again to stop the automatic operation.

- *Opening the sun blind:* Push the button ① to the first position. Automatic operation: Push the button ① to the second position.
- *Closing the sun blind:* Push the button ② to the first position. Automatic operation: Push the button ② to the second position.
- *Switching the automatic operation on or off:* Press the button ① or ② again.

The sun blind can be operated several minutes after the ignition has been switched off, provided that the driver door and front passenger door are not opened.

Roll-back function for the sun blind

The roll-back function can reduce the risk of injuries when closing the sun blind. → . The glass roof or the sun blind will open again immediately if the sun blind is unable to close because it is stiff or obstructed.

- Check to see why the sun blind has not closed.
- Try to close the sun blind again.
- The sun blind will open again immediately if it is still unable to close because it is stiff or obstructed. After opening, the sun blind can be closed again within a short period of time without the roll-back function.
- If the sun blind still cannot be closed, close it without the roll-back function.



Closing the sun blind without the roll-back function

- Within approximately 5 seconds of the roll-back function being triggered, press and hold the button → [Fig. 76](#)  until the sun blind has closed completely.
- **The sun blind will now close without the roll-back function!**
- Please go to a correspondingly qualified workshop if the sun blind still cannot be closed. Volkswagen recommends using a Volkswagen dealership.

WARNING

Closing the sun blind without the roll-back function can cause serious injuries.

- Always take care when closing the sun blind!
- When closing the sunshade rolling curtain, ensure that no one is within the working range of the skylight, especially when the anti-clip function does not work. Ensure that nobody obstructs the path of the sun blind, especially if the roll-back function is not active when it is closed.
- The roll-back function cannot protect fingers or other parts of the body from being clipped at the frame of glass roof.

 When the glass roof is open, the electric sun blind can be closed only up to the front edge of the glass roof. 

Air conditioning system

Heating and air conditioning system

Introduction

This chapter contains information on the following subjects:

- | | |
|---|----|
| – Climatic operating mechanism | 85 |
| – Automatic air conditioning system (Climatronic) | 87 |
| – Air conditioning settings in the Infotainment System | 88 |
| – To adjust the temperature settings of driver side for all seats in sync | 88 |
| – Seat heating | 89 |
| – Troubleshooting | 90 |

The vehicle may be equipped with the following air conditioning units:

Climatic Or **Climatronic** heats, cools, and dehumidifies the air. The air conditioning system will work most effectively if the vehicle interior is kept closed. Opening the windows and glass roof to provide fresh air may accelerate cooling down the vehicle if high temperatures have built up in the vehicle interior.

Display of active functions

Lit up LEDs on the air conditioning block indicate that the function is switched on.

Dust and pollen filters

Dust and pollen filters reduce pollutants brought into the vehicle by the outside air.

Dust and pollen filters must be replaced according to the time interval specified in Maintenance Manual to avoid affecting the efficiency of air conditioning.

When the vehicle is used in an environment with high air pollution, the performance of the dust and pollen filters will be affected. Replace the dust and pollen filters more frequently, if necessary, within the prescribed maintenance intervals.

WARNING

Make sure all windows have a clear view to prevent collisions and accidents. 

- Keep all windows free of ice, snow, and condensation.
- There is enough heat generated to quickly remove the condensation on the window after the engine reaches the operating temperature. Only set off once all windows are clear.
- Use the air conditioning and rear window heating to prevent condensation from forming on the windows.
- Use air recirculation mode for a short period only. Condensation could otherwise form very quickly on the windows, greatly reducing visibility.
- Switch off the air recirculation mode as soon as it is no longer required.

⚠ WARNING

Lack of a fresh air supply can lead to restricted visibility (due to misted-up windows) and quicker driver fatigue (due to stale air). This can lead to collisions and accidents and cause severe or fatal injuries.

- Use air recirculation mode for a short period only. Switch off the air recirculation mode as soon as it is no longer required.

ⓘ NOTICE

Foodstuffs, medicines and objects that are sensitive to heat or cold can be damaged or made unusable by the air flowing out of the vents.

- Never leave food, medicines or other temperature-sensitive objects in front of the vents.

ⓘ NOTICE

- If the air conditioning system is suspected to be faulty, switch off the air conditioning to avoid further damage and go to a correspondingly qualified workshop. Volkswagen recommends using a Volkswagen dealership. ◀

Climatic operating mechanism

📖 Please refer to **⚠** and **ⓘ** at the start of the chapter on page 84.

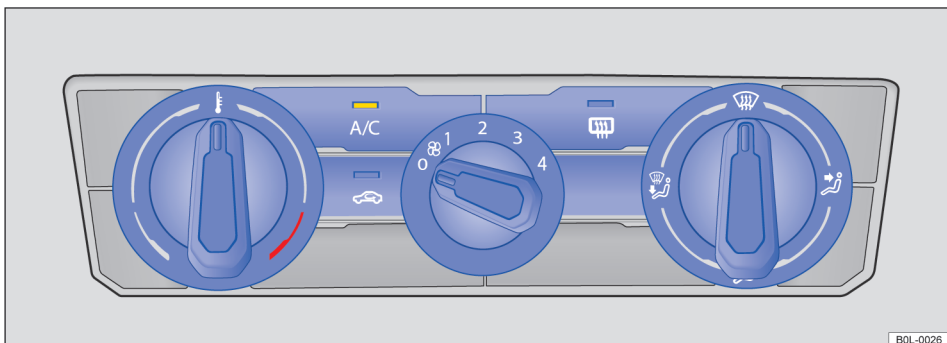

Fig. 77 In the upper part of the centre console: climatic operating mechanism

Depending on the equipment level, the function and buttons of the air conditioning system may vary.

Press the corresponding button to turn a function on or off. To disable a function, press the button again.

Lit up LEDs on the air conditioning block indicate that the function is switched on.

Switch off

- Turn the blower adjustment knob anticlockwise to gear 0. ▶

-- Temperature regulation

- Turn the left thermostat → Fig. 77.

- Blower

- Turn the central blower adjustment knob → Fig. 77.

- Defrost function

The defrost function clears the windscreen of ice, snow and condensation.

- Turn the right air distribution regulator into position  → Fig. 77.

In the defrosting function mode, the air recirculation mode is automatically switched off, and the air conditioning compressor is switched on automatically (if environmental conditions are met), to reduce the humidity inside the vehicle.

Air distribution



- Direct air towards upper body.



- Direct air into the footwell.



- Guide air to the windscreen and the footwell.

A/C – Cooling mode

- Press the button  on the air conditioner panel to switch on or off the cooling mode.

The air is cooled and dehumidified in cooling mode.

– Rear window heating

- Press the button on the air conditioner panel  to switch the rear window heating on or off while the engine is running.

Depending on the outside temperature, the exterior rear mirror may heat up simultaneously.

The rear window heating switches off automatically after around 10 minutes at the latest.

– Air recirculation mode



When air recirculation mode is switched on, no fresh air enters the vehicle interior. → page 88

- Press the button .

Front window defrost

- Turn the air distribution regulator → Fig. 77 into position .
- Turn the blower adjustment knob → Fig. 77 to the 3rd gear. If the engine has reached the best operating temperature, the blower speed can be reduced moderately.
- Turn the temperature control knob → Fig. 77 right to stop.
- Align the air outlet on the left and right sides of the front row with the side windows.

Front window decondensation

- Adjust the temperature control knob → Fig. 77 to set the temperature as desired.
- Turn the blower speed adjustment knob → Fig. 77 to the 2nd or 3rd gear.
- Turn the air distribution knob → Fig. 77 to  gear.
- Press the button  to start the air conditioner.
- Align the air outlet on the left and right sides of the front row with the side windows.

Recommended settings for semi-automatic air conditioning system

- Air recirculation mode.
- Set the blower speed as desired.
- Turn the thermostat to middle position.
- Open all air vents on the dash panel and align them.
- Turn the air distribution regulator to the desired position.
- Press the button  on the air conditioner panel to switch on the cooling system, which humidify the air in cooling mode.

NOTICE

Do not stick any stickers over the heating wires of the rear window heating. Otherwise, the rear window heating may be damaged.

Automatic air conditioning system (Climatronic)

📖 Please refer to ⚠️ and ⌚ at the start of the chapter on page 84.

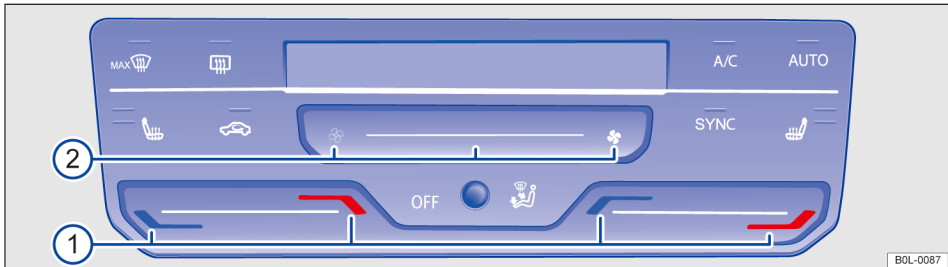

Fig. 78 In the upper part of the centre console: climatronic operating mechanism

Some functions of the air conditioning system depend on the vehicle equipment.

Switch off

- Click the button in the air conditioning menu (OFF) → Fig. 78
- Or: Press the button (OFF) → Fig. 78 (2) the blower adjustment function on the left, until the display screen above the control panel shows OFF.

SYNC - Combined temperature regulation on the driver side and front passenger side

- Press the button in the air conditioning block (SYNC), the temperature set on the driver side also applies to the front passenger side.

AUTO - Automatic mode

The set air temperature is kept constant. The temperature, blower speed, and air distribution are controlled automatically. Automatic mode switches off when the blower speed is adjusted manually.

A/C - Cooling mode

- Press the button (A/C) on the air conditioner block to switch on or off the cooling mode.

The air is cooled and dehumidified in cooling mode.

Temperature regulation

- Press temperature button → Fig. 78 (1) to adjust the driver and front passenger side temperature.

Climatronic shows the temperature settings.

Seat heating

- Press the button (left or right) to switch on or off the seat heating. → page 89

Blower

- Press the blower adjustment button → Fig. 78 (2).

The blower gear of the regulator is not displayed in the automatic mode.

Air recirculation mode

When air recirculation mode is switched on, no fresh air enters the vehicle interior. → page 88

- Press the button (recirculation).

Air distribution

- By repeatedly pressing the button (distribution), the air flow can be separately guided to the front windscreen, upper body and foot of the passenger, or to the two areas at the same time.

Symbols on the screen above the block can be displayed in different ways depending on the air distribution area.

MAX - Defrost function

The defrost function clears the windscreen of ice, snow and condensation.

- Press the button (MAX) → Fig. 78.

For rapid defrosting or defogging, the blower speed is raised to a higher speed.

Rear window heating

- Press the button (rear window heating) to switch the rear window heating on or off while the engine is running. ▶

Depending on the outside temperature, the exterior rear mirror may heat up simultaneously.

The rear window heating switches off automatically after around 10 minutes at the latest.

Recommended settings for climatronic

- Press the button .
- Set the temperature to +22 °C.
- Open and adjust the air vents on the dash panel.

Air conditioning settings in the Infotainment System

 Please refer to  and  at the start of the chapter on page 84.

The air conditioning settings in the Infotainment System are suitable for fully automatic air conditioning (Climatronic). Some functions depend on configuration.

Open the air conditioner settings menu

- Click the button in the infotainment system .

Running state

The running states of the air conditioner are highlighted in colour:

- Blue: Cooling.
- Red: Heating.

Infotainment System: Air conditioning submenu

AUTO The set air temperature is kept constant. The temperature, blower speed, and air distribution are controlled automatically. The blower speed in automatic mode can be controlled through the air conditioning mode. Automatic mode switches off when the blower speed is adjusted manually.



Adjust the blower speed.



Switch air recirculation mode on and off
→ page 88.

MAX A/C Switch maximum cooling output on and off depending on the vehicle type. Air recirculation mode is automatically switched on and the Climatronic automatically directs air to the upper body.

A/C Switch on or off the cooling mode.

NOTICE

Do not stick any stickers over the heating wires of the rear window heating. Otherwise, the rear window heating may be damaged. 



Direct air into the footwell.



Direct air towards upper body.





Guide air to the windscreen.

Air distribution buttons can be used in combination.

Set the temperature in the vehicle.

Set the temperature in the air conditioning setting menu:

- Press the button  or  in the Infotainment system.

Adopt temperature settings

To adjust the temperature settings of driver side for all seats in sync. 

To adjust the temperature settings of driver side for all seats in sync



 Please refer to  and  at the start of the chapter on page 84.



When air recirculation mode is switched on, no fresh air enters the vehicle interior.

Manual air recirculation mode

- Press the button  on the air conditioner block to switch on or off the air recirculation mode.

Air recirculation mode automatically switches off

The air recirculation mode automatically switches off under the following conditions →  

- *Climatronic*: Press the button  on the air conditioner panel.
- *Climatic*: Turn the air distribution regulator to .

WARNING



Lack of a fresh air supply can lead to restricted visibility (due to misted-up windows) and quicker driver fatigue (due to stale air). This can lead to collisions and accidents and cause severe or fatal injuries.

- Use air recirculation mode for a short period only. Otherwise, the fresh air cannot enter the vehicle interior.
- If the air conditioning cooling system is closed or if you driving in cold areas, condensation will form very quickly on the windows, greatly reducing visibility.
- Switch off the air recirculation mode as soon as it is no longer required.



NOTICE

For models equipped with air conditioning system, never smoke in the vehicle after the air recirculation mode is switched on. Otherwise, tobacco smoke can leave a residue on both the evaporator of the air conditioning system and the inhaled air filter with activated carbon, producing a lasting unpleasant odour.

 When reversing the vehicle or when the wash and wipe system is being used, switch on the air recirculation mode to prevent odours from entering the vehicle interior.







 If the outside temperature is very high, brief activation of air recirculation mode helps to cool the vehicle interior more quickly. 

Seat heating

 Please refer to  and  at the start of the chapter on page 84.

When the engine is running, the seat surface and backrest can be electrically heated.

Operating the seat heating

- press the button  or  in the air conditioning block to switch on the seat heating with the highest temperature setting.
- Press the button  or  repeatedly to the position needed.
- Press the button  or  until no LED is lit to switch the seat heating off.

When the ignition is switched off, the seat heating is switched off simultaneously. The most recent temperature setting for the driver seat is switched on automatically if you start the engine again within approximately 10 minutes. Switch the passenger side seat heating on after the ignition is switched on, if necessary.

When should the seat heating be switched off?

Switch off the seat heating if one of the following conditions applies:

- A person with reduced sensitivity to pain or temperature is sitting on the seat → .
- The seat is not occupied.
- A protective cover is equipped.
- A child seat is installed on the seat.
- The seat cushion is damp or wet.
- The temperature in the vehicle interior or the outside temperature is above +25°C.

WARNING

Anyone with reduced sensitivity to pain or temperature due to medication, paralysis or chronic illness (e.g. diabetes) could sustain burns on the back, buttocks and legs when using the seat heating. These burns may take a long time to heal or may never heal fully. Thus, it is necessary to check your own state of health before using the seat heating.

- Never use the seat heating if you have reduced sensitivity to pain or temperature.

WARNING

Wet seat cushions can cause a malfunctions in the seat heating and increase the risk of burns.

- Ensure that the seat cushion is dry before using the seat heating.
- Do not sit on the seat in damp or wet clothing. 

- Do not place any damp or wet objects or items of clothing on the seat.
- Do not spill any liquids on the seat.

NOTICE

- Do not kneel on the seats and do not apply any other point loads to the seat cushion and backrest.
- The heater elements of the seat heating can be damaged by liquids, pointed objects, insulating materials (e.g. seat covers), or child seats.
- If odours develop, switch off the seat heating immediately and have it checked by a suitably qualified workshop. Volkswagen recommends using a Volkswagen dealership.
- When adding additional seat cushions or changing the original seat fabric material, the seat heating may be limited or the heating temperature may be too high.

 To save fuel, switch off the seat heating as soon as possible.

Troubleshooting

 Please refer to  and  at the start of the chapter on page 84.

Cooling mode cannot be switched on or operation is restricted

Cooling mode works only when the engine is running and at ambient temperatures above +3°C.

The cooling mode may be restricted when the engine is very hot or at extreme outside temperatures.



- Switch on the blower.
- Check the fuse → page 157 of the air conditioning system.
- Replace dust and pollen filters.
- If the fault persists, go to a correspondingly qualified workshop. Volkswagen recommends using a Volkswagen dealership.

Heating and fresh air system cannot be switched on or operation is restricted

- The heating and ventilation system and defrosting function work better when the engine is warm.
- If the fault persists, go to a correspondingly qualified workshop. Volkswagen recommends using a Volkswagen dealership.

Condensation forms on windows

Condensation may form on the windows if they are colder than the ambient temperature and the air is very humid. Cold air can absorb less moisture than warm air, which is why condensation frequently forms on windows in cold weather.

- In order to improve the heating and cooling output, keep the air intake in front of the windscreen free of ice, snow and leaves → page 204.
- Keep the air slots in the rear area of the luggage compartment clear so that air can flow through the vehicle from the front to the rear.
- Press the button  or turn the regulator into  position to switch the Defrost function on. → .

Water stains under the vehicle

If the humidity and temperature outside the vehicle are high, **condensation** can drip off the evaporator in the cooling system and form a pool underneath the vehicle. This is normal and does not indicate a leak.

WARNING

Make sure all windows have a clear view to prevent collisions and accidents.

- Keep all windows free of ice, snow, and condensation.
- Only when the engine is running can the ice and snow be removed from the windows as quickly as possible with the highest temperature setting. Only set off once all windows are clear.
- Use the air conditioning and rear window heating to prevent condensation from forming on the windows.

Driving

Notes on driving

Pedals

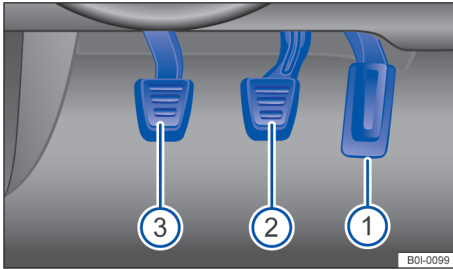

Fig. 79 In the footwell: pedals in vehicles with a manual gearbox (illustration)

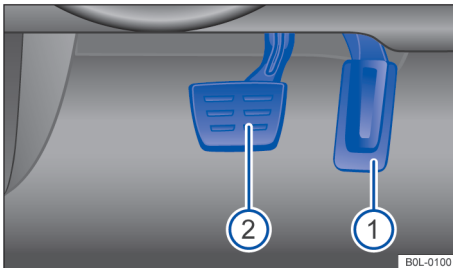

Fig. 80 In the footwell: pedals in vehicles with an automatic gearbox (illustration)

Fig. 79 and Fig. 80:

- ① Accelerator
- ② Brake pedal
- ③ *Vehicles with a manual gearbox:* Clutch pedal

Make sure that all pedals can always be operated without any hindrance.

Use floor mats that do not impede the movement of the pedals and can be properly secured in the footwell only.

⚠ WARNING

Objects in the driver footwell can hinder pedal operation. This can lead to loss of control of the vehicle and increase the risk of serious or fatal injuries.

- Make sure that all pedals can be operated smoothly at all times.

- The floor mats must always be properly secured in the footwell.
- No additional floor mats or other floor coverings should be placed over the fitted floor mat.
- Make sure that no objects can enter the driver footwell while the vehicle is in motion.
- If there are any objects in the footwell, remove them when the vehicle is parked.
- Always wear shoes that provide good grip for your feet when using the pedals.

ⓘ NOTICE

Make sure that the driver can reach the pedal at all times. For example, if a brake circuit fails, a larger brake pedal travel will be necessary in order to stop the vehicle. Therefore, the driver needs to depress the brake pedal fully with more force and time than usual.

Gear-change indicator

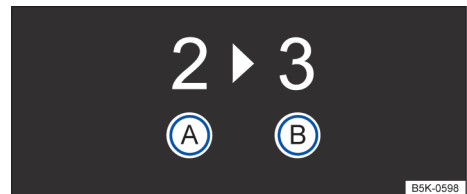

Fig. 81 On the instrument cluster display: gear-change indicator (schematic diagram).

Fig. 81 jump leads:

- Ⓐ Currently selected gear.
- Ⓑ Recommended gear.

Depending on the vehicle equipment, the instrument cluster display may indicate which gear should be selected in order to reduce fuel consumption while the vehicle is in motion.

Vehicles with an automatic gearbox: the gearbox must be in Tiptronic mode for this → page 106.

No recommended gear is indicated if the most suitable gear is already selected. The currently selected gear is displayed.

CAUTION

The gear-change indicator is designed only to assist the driver and cannot replace the driver's attention and responsibility.

- Always select the correct gear for the respective driving situation, e.g. when overtaking, driving uphill or downhill, or towing trailers.

 Driving in the correct gear can help to reduce fuel consumption.

 The gear-change indicator display goes out when the clutch is depressed (in vehicles with a manual gearbox) or when the Tiptronic position is deselected (in vehicles with an automatic gearbox).

Driving economically

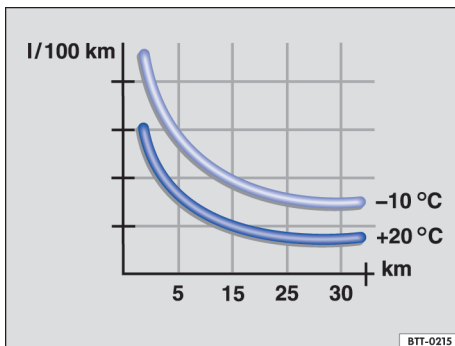

Fig. 82 Fuel consumption in litres per 100 km at two different outside temperatures.

Adopting the correct driving style can reduce fuel consumption, pollution and wear-and-tear on the engine, brakes and tyres. The following section lists a few tips for easing the strain on the environment and your bank account.

Think ahead when driving

Repeated acceleration and braking will increase fuel consumption. Keeping a close eye on the traffic can help to avoid frequent acceleration and braking. Keeping your vehicle at a sufficient distance from the vehicle in front can help you to think ahead when driving.

Allow the vehicle to coast with the gear engaged in order to take advantage of the engine braking effect, for example when approaching a red street light.

Change gear to save energy

Shifting up early at engine speeds of 2,000 rpm can save energy. Do not drive gears to the limit and avoid high revs.

Vehicles with a manual gearbox: change from 1st to 2nd gear immediately after moving off.

Vehicles with an automatic gearbox: accelerate slowly and avoid using the kickdown function.

Gear-change indicator → page 91.

◀ Avoid full throttle

Never drive the vehicle at top speed. The rolling and air resistance increase at excessively high speeds. This in turn increases the force needed to move the vehicle.

Reduce idling

Drive off immediately at low engine speeds. If you are stopped for a long period, do not allow the engine to idle but switch it off, e.g. when in a traffic jam or at a railway crossing.

In vehicles with an activated start/stop system, the engine can switch off automatically when the vehicle is stopping and when the vehicle is stationary → page 101.

Fill the fuel tank properly

Filling the fuel tank all the way to the top will increase the vehicle weight. A fuel tank that is half to three quarters full is sufficient for urban journeys in particular.

Avoid short journeys

Engines consume a lot of fuel when cold. They do not reach optimum operating temperature until the vehicle has travelled a few kilometres. The fuel consumption is above average at very low ambient temperatures, e.g. in winter → Fig. 82. Plan your journeys economically and combine several short trips.

Regular maintenance

Regular maintenance is an essential prerequisite for economical driving and increases the service life of the vehicle. ▶

Observe the correct tyre pressures

An inadequate tyre pressure does not just mean greater wear, but also increases the rolling resistance of the tyres and thus the fuel consumption. Use tyres with optimised rolling resistance.

Adjust the tyre pressure according to the vehicle load. Observe the information on the tyre pressure sticker → page 186.

Tyre pressure monitoring system → page 183.

Use low viscosity engine oil

The use of synthetic low viscosity engine oil can reduce fuel consumption. As low viscosity engine oil can decrease frictional resistance in the engine and spread better and more quickly, especially for cold starts.

Do not drive with unnecessary loads in the vehicle

You can reduce fuel consumption by clearing out the luggage compartment before setting off, for example by removing empty drink crates or unused child seats.

Save electrical energy

The alternator powered by the engine generates electricity for convenience functions, such as the air conditioning system, windscreen heating or ventilation system. Saving electrical energy is easy, for example:

- At high ambient temperatures, ventilate the car before starting a journey and drive a short distance with open window. Only then switch on the air conditioning system.
- Switch off convenience systems as soon as they have served their purpose.



WARNING

The reduced air density may result in reduced engine output as altitude increases. This may cause accidents and serious or fatal injuries, for example, when overtaking.

- Always adjust your speed and driving style according to visibility, weather, road, and traffic conditions.

WARNING

Adapt your speed and distance from the vehicles ahead to suit visibility, weather, road, and traffic conditions.

 Your Volkswagen dealership will gladly provide you with further information on correct maintenance and replacement parts that are particularly energy-efficient, e.g. new tyres. 



Information on the brakes

During around the first 300 km, **new brake pads** cannot generate the full braking effect and must be “run in” → . However, you can compensate for the slightly reduced braking force by applying more pressure to the brake pedal. **During the run-in period, the braking distance is longer when the brakes are depressed fully or during emergency braking than with brake pads that have been fully run in.** In the run-in period, the brakes should not be depressed fully and situations should be avoided that create a heavy load on the brakes, e.g. when driving up close to the vehicle ahead.

Brake pad wear The wear of the brake pads depends to a great extent on the conditions under which the vehicle is operated and the way in which the vehicle is driven. If the vehicle is used for regular urban trips or short journeys and is driven with a sporty driving style, the brake pads must be regularly checked according to the Maintenance Manual.

After driving through water, after heavy rainfall, or after washing the vehicle, the braking effect may be delayed as the brake discs will be **wet**, or possibly iced up (in winter). The brakes must be “dried” as quickly as possible by careful braking at higher speed. Make sure that no following vehicle and no other road user is put at risk as a result of this action → .

Any salt layer accumulating **on the discs and pads** will delay the braking effect and increase the braking distance. If the brakes on the vehicle have not been applied for a long time on roads that have been gritted with salt, the layer of salt must be reduced through careful braking → .

Corrosion on the brake discs and dirt in the brake pads are facilitated **through long periods of parking or inactivity.** If the brake pads have been hardly used or if they are corroded, Volkswagen recommends that the brake discs and brake pads be cleaned by braking strongly several times from high speed. Make sure that no following vehicle and no other road user is put at risk as a result of this action →  

WARNING

Driving with worn brake pads or a faulty brake system can lead to loss of control of the vehicle, accidents, and serious or fatal injuries.

WARNING

New brake pads cannot generate the full braking effect.

- New brake pads cannot generate the full braking effect during the first 300 km or so and must first be bedded in. However, you can compensate for the slightly reduced braking force by applying more pressure to the brake pedal.
- Drive with particular care with new brake pads to reduce the risk of accidents, serious injuries, and loss of control of the vehicle.
- Never drive too close to other vehicles when running in new brake pads, and never create a driving situation that will place a heavy load on the brakes.

WARNING

Constant braking will cause the brakes to overheat. This can significantly reduce the braking performance, increase the braking distance and, in certain circumstances, cause the brake system to fail completely.

- Never depress the brake pedal too often and for too long.

WARNING

Overheated brakes reduce the braking effect and considerably increase the braking distance.

- When driving downhill, the brakes are placed under particular strain and become hot very quickly.
- Before driving down a long, steep gradient, reduce your speed by changing to a lower gear (e.g. in Tiptronic mode of the automatic gearbox). Use the braking effect of the engine to reduce the load on the brakes.
- Before starting your journey, make sure that the air supply to the brakes is not covered, e.g. by non-standard or damaged front spoilers.

WARNING

Wet brakes or brakes coated with ice or road salt react more slowly and require longer braking distances. This can cause you to lose control of the vehicle and can lead to accidents and serious or fatal injuries.

- Be careful when braking.
- Carry out a few careful braking operations to dry the brakes and clean off any coating of ice and salt when visibility, weather, road and traffic conditions permit.

 If the front brake pads are tested, the rear brake pads should be tested at the same time. Regularly check the thickness of the brake pads through the openings in the rims or from the underside of the vehicle. If necessary, remove the wheels to carry out a comprehensive check. Further information can be obtained from a correspondingly qualified workshop. Volkswagen recommends using a Volkswagen dealership. <

Driving a loaded vehicle

For good vehicle handling when driving a loaded vehicle, please observe the following:

- Stow all items of luggage securely → page 144.
- Accelerate particularly cautiously and carefully.
- Avoid sudden braking and rapid accelerating.
- Brake earlier than in normal driving.

WARNING

Shifting loads can severely impair the vehicle's stability and driving safety in the event of hard or emergency braking. This can cause accidents and serious or fatal injuries.

- Secure the load properly to prevent it from slipping.
- Use suitable lashing or securing straps when securing heavy objects.
- Securely engage the rear seat backrests in an upright position before loading. <

Driving with an open boot lid

Driving with an open boot lid is extremely dangerous. Ensure that the open boot lid and any objects are secured properly, and take appropriate measures to reduce the quantity of toxic exhaust fumes entering the vehicle.

WARNING

Driving with the boot lid unlocked or open may cause accidents and serious or fatal injuries.

- Always drive with the boot lid closed.
- Stow all items securely in the luggage compartment. Otherwise, loose items may fall out and cause injury to other road users.
- Always drive carefully and ensure that you think ahead.
- Avoid any abrupt or sudden driving and braking manoeuvres as this can cause the open boot lid to move unpredictably.
- If items protrude from the luggage compartment, make sure that they are visible to other road users while complying with the relevant traffic regulations.
- Never use the boot lid to jam or fix objects in place.
- If it is necessary to drive with the boot lid open, always remove a luggage rack and its load from the boot lid.

WARNING

When driving with the boot lid open, toxic exhaust gases can enter the vehicle interior and lead to unconsciousness, carbon monoxide poisoning, accidents and serious or fatal injuries.

- Always drive with the boot lid closed in order to prevent poisonous exhaust gases from entering the vehicle.
- If you have to drive with the boot lid open, the following measures must be taken to avoid the toxic exhaust gases entering the vehicle interior:
 - Closing all the doors, windows and the tilted glass roof.
 - Switch off air recirculation mode.
 - Open all vents in the dash panel.
 - Switch the blower to the highest blower speed.

NOTICE

The height and possibly also length of the vehicle are different when the boot lid is open. <

Driving through water

Follow the precautions below to help prevent damage to your vehicle when driving through water (for example, if the road is flooded):

- Observe the water depth before driving through the waterlogged road. The water level must be **no higher than** the lower edge of the vehicle body → .
- Do not drive faster than walking speed.
- Never stop the vehicle, reverse or switch off the engine while in water.
- Oncoming vehicles will create waves that could increase the water level for your vehicle to such an extent that it is not safe to drive through the water.
- Always deactivate the start/stop system manually when driving through water → page 101.

WARNING

After driving through water, mud, slush etc., the brakes may react slowly and the braking distance will be increased as the brake discs and pads will be wet, or possibly iced up (in winter).

- Carry out careful braking manoeuvres several times to “dry and de-ice the brakes”. Do not endanger other road users when performing braking manoeuvres and do not ignore any legal requirements.
- Avoid abrupt and sudden braking manoeuvres directly after driving through water.

NOTICE

If you drive through water, parts of the vehicle, e.g. engine, transmission system, travel system, and electronics, could sustain severe damage or corrode.

- Never drive through salt water. Immediately rinse all vehicle parts that have come into contact with salt water using fresh water.
- Avoid the engine from getting wet. When driving on roads with low-lying water, be careful to prevent the engine from getting wet, as it >

will seriously damage the engine. Volkswagen is not responsible for any vehicle malfunctions or damage caused by this.

Running in the engine

The new engine must undergo a run-in period during the first 1500 km of driving. All moving parts should be able to work together smoothly. Friction resistance during the first few hours of engine operation will be greater than after the break-in period.

During the initial 1,000 km run-in period:

- Avoid depressing the accelerator pedal fully.
- Do not exceed two-thirds of the maximum engine speed while driving.

During the 1,000 to 1,500 km run-in period:

- *Gradually* increase the vehicle speed and engine speed to the maximum allowable speed.

The driving style during the first 1,500 km also affects the engine quality. It is recommended to drive at moderate engine speeds (especially when the engine is cold), to reduce engine wear and increase the available driving distance.

Avoid driving at too low of an engine speed. When the engine no longer runs "smoothly", be sure to downshift.

New tyres → page 183 and brake pads → page 91 must be carefully run in.

 Following the above requirements for proper engine run-in not only extends the engine's service life but also reduces oil consumption.

Information on driving abroad

This vehicle is specially manufactured for China and complies with the vehicle registration management regulations in force in the country at the time of production.

If the vehicle needs to be used abroad temporarily or for a short period, appropriate notices should be taken into consideration → page 26.

In some countries, special standards and regulations may be adopted which differ from the technical status of this vehicle. We recommend that you should be aware of the legal requirements of the destination country before driving abroad.

If you plan to sell the vehicle to other countries or use it for a long time in other countries, you must comply with the relevant country's legal requirements.

In some cases, it may be necessary to install or remove certain equipment, and disable certain functions, which may require corresponding changes to the maintenance scope and type, especially when driving in regions with different climates, you should pay attention to the maintenance scope and type specified by that region.

Due to the use of different frequency bands in different countries, the infotainment system may not work when driving in some countries.

NOTICE

- Vehicle malfunctions and damages caused by the use of substandard fuel, improper maintenance, or the installation of non-original spare parts are not covered under the warranty.
- Volkswagen does not assume responsibility for vehicles used in other countries that do not comply with or only partially comply with the relevant national regulations.

Troubleshooting

Brake system fault

The warning lamp lights up red.

A text message may also be displayed.

Do not drive on!

- Seek expert assistance from a Volkswagen dealership for professional testing of the brake system.

If the braking performance of the vehicle changes

If the brake pads are worn or if you establish that the vehicle is no longer braking in the usual way (e.g. a sudden lengthening of the stopping distance):

- In this case, go to a suitably qualified workshop immediately and have the system checked. Volkswagen recommends using a Volkswagen dealership.

Starting or switching off the engine

Ignition Lock

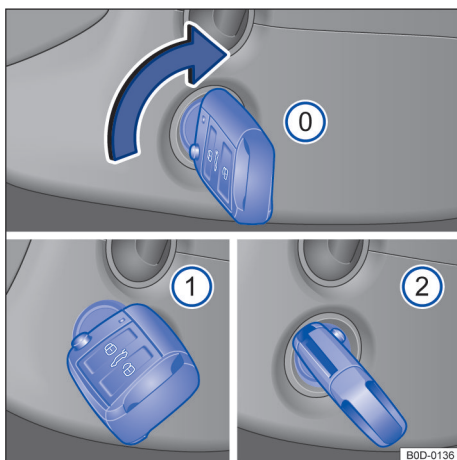



Fig. 83 To the right of the steering wheel: positions of the vehicle key in the ignition lock.

The steering lock is activated when there is no vehicle key in the ignition lock.

Location of vehicle key → Fig. 83

- ① Ignition switched off. The vehicle key can be removed.
- ② Ignition switched on. Steering lock can be released.
- ③ When the indicator  lights up green, depress the brake pedal and start the engine. Once the engine starts, release the vehicle key. The vehicle key moves back to position ①.

Warning when the ignition is switched on

A warning message appears in the instrument cluster display if the driver door is opened while the ignition is switched on. An acoustic signal may also be given.

The warning is a reminder that the ignition must be switched off before leaving the vehicle.

⚠ WARNING

Use vehicle keys with care as improper usage or management may lead to accidents or injuries.

- Always take all vehicle keys with you when you leave the vehicle. If the vehicle key is left unattended in the vehicle, children or unauthorised persons could start the engine or switch on the ignition and thus operate electrical equipment, such as the electric windows. This can result in accidents and serious or even fatal injuries.
- Do not leave children or individuals who need assistance alone in the vehicle. In case of an emergency, they may become trapped in the vehicle and unable to safely evacuate or seek help. For example, during seasonal changes, the interior of a closed vehicle can become extremely hot or cold, which can cause injury, illness, or even death to the occupants, particularly young children who are more vulnerable.
- Never remove the key from the ignition lock while the vehicle is in motion. Otherwise, the steering lock may engage and you will no longer be able to steer the vehicle. This can result in accidents and serious or even fatal injuries.
- Always completely unfold the key bit of the vehicle key and lock it in this position.
- Attach only light objects weighing less than around 100 g to the vehicle key.

ⓘ NOTICE

The 12-volt battery may be discharged unintentionally and prevent the engine from restarting if the ignition is switched on while the engine is switched off.

- Always switch off the ignition before you leave the vehicle.

 *Vehicles with an automatic gearbox:* If the vehicle key cannot be removed, select the selector lever position **P**. If necessary, press the lock button in the selector lever and then release it.

Starter button



Fig. 84 In the lower section of the centre console: starter button for starting the engine.

The starter button replaces the ignition lock (Press & Drive).

The engine is started by pressing the starter button (Press & Drive).

The vehicle can be activated only if there is a valid vehicle key in the vehicle.

When leaving the vehicle, the electronic steering lock will be **activated when** the ignition is switched off and the driver door is opened → page 108.

Switching the ignition on or off

Press the starter button once without depressing the brake or clutch pedal. → 

Automatic ignition switch-off

Once the vehicle key is removed, the ignition will be switched off automatically after a certain period of time. If the dipped beam is switched on, the width light will continue to illuminate for approximately 30 minutes. The width light can be switched off by locking the vehicle or manually → page 72.

Engine restart function

If no valid vehicle key is detected in the vehicle interior once the engine has been switched off, it is possible to restart the engine within approximately 5 seconds. A corresponding message appears on the instrument cluster display.

After this time, the engine cannot be restarted without a valid vehicle key in the vehicle interior.

WARNING

While driving, it is important to prevent passengers from accidentally pressing the starter button. Otherwise, it may activate the engine emergency shutdown function and cause an accident.

- If the emergency shutdown function is accidentally activated while driving, follow these steps to restart the engine:
 - Move the selector lever to position **N** or move the gear lever to neutral position.
 - Depress the clutch pedal or brake pedal and press the starter button.
 - Engine restarts.

Do not move the selector lever to **P** while driving a vehicle equipped with an automatic gearbox, otherwise the gearbox may be damaged.

WARNING

Unintentional vehicle movements may cause accidents and serious or fatal injuries.



- The engine will *start immediately* if the brake pedal or clutch pedal is depressed when the ignition is switched on.

WARNING

Use vehicle keys with care as improper usage or management may lead to accidents or injuries.

- Always take all vehicle keys with you when you leave the vehicle. Otherwise, children or unauthorised persons could lock the vehicle, start the engine or switch on the ignition and thus operate electrical equipment, such as the electric windows.

 Always manually switch off the ignition before leaving. If necessary, pay attention to any prompts on the instrument cluster display.

 The 12-volt battery may be discharged unintentionally and prevent the engine from restarting if the ignition is switched on while the engine is switched off. 

Starting the engine

- *Vehicles with ignition lock:* Turn the vehicle key to position → Fig. 83 ①. Switch on the ignition.
- *Vehicles with starter button:* press the starter button. Switch on the ignition.
- depress the brake pedal and hold it until the electronic parking brake is switched off.
- *Vehicles with a manual gearbox:* fully depress the clutch pedal and hold it until the engine has been started. Move the gear lever to neutral position.
- *Vehicles with an automatic gearbox:* Move the selector lever to position **P** or **N**.
- *Vehicles with ignition lock:* turn the vehicle key in the ignition lock to position → Fig. 83 ② without depressing the accelerator.
- Release the vehicle key once the engine has started.
- *Vehicles with starter button:* press the starter button → page 98 without depressing the accelerator. There must be a valid vehicle key in the vehicle.
- If the engine does not start immediately, stop the starting procedure and try again after around 1 minute.
- *Vehicles with starter button:* Perform emergency start → page 101 when necessary.
- *Vehicles with starter button:* the starter button is deactivated if the vehicle was locked using the vehicle key. If you are in the vehicle and need to start the engine, unlock the vehicle first or perform an emergency start → page 101.
- Switch off the electronic parking brake before you start driving.

WARNING

To reduce the risk of injury or death while starting or running the engine, pay attention to the following:

- Never start or run the engine in an enclosed or poorly ventilated space. The engine exhaust gas contains colourless and odourless poisonous carbon monoxide, which can cause unconsciousness and death.
- Do not start the engine if there is a spill of oil, fuel, or other flammable materials under or around the vehicle or if they are leaking from the vehicle.

- Never leave the vehicle unattended with the engine running, particularly if a gear or position has been selected. The vehicle may suddenly move or experience abnormal events, resulting in damage, fire, and serious injury.

WARNING

Never start the engine using an accelerator as it may cause an explosion or sudden high-speed operation of the engine.

- Never use start boosters.

NOTICE

- Avoid restarting the engine while the vehicle is in motion or directly after switching off the engine.
- When the engine is cold, avoid high engine speeds, driving at full throttle, and overloading the engine.
- Never attempt to start the engine by pushing or towing the vehicle. This may cause unburned fuel to enter and damage the catalytic converter.

NOTICE

Never use the engine for driving or towing the vehicle in gear with the key in the ignition position → Fig. 83 ②, for example when the fuel tank is empty. This may damage the engine.

- Add fuel if necessary → page 147 or use a jumper cable to start the engine. → page 159.
- If the engine does not start, seek expert assistance from a Volkswagen dealership for professional testing.

NOTICE

Please note that the density of air decreases with increasing altitude and this may make it more difficult to start the engine.



Do not warm up the engine by running it while the vehicle is stationary. Instead, pull off as soon as there is good visibility through the windows. This helps the engine reach operating temperature faster and reduces emissions.





When the engine is started, electrical consumers with a higher power consumption are temporarily switched off.

 The engine cannot, for example, be started with the starter button if the button cell in the vehicle key is weak or flat. Carry out an emergency start → page 101.

 When starting from cold, the engine may run with increased operating noise for a short time. This is quite normal, and no cause for concern.

Switching off the engine

- Bring the vehicle to a standstill → .
- Park the vehicle → page 122.
- *Vehicles with ignition lock:* Turn the vehicle key in the ignition lock to position → Fig. 83 .
- *Vehicles with starter button:* briefly press the starter button → Fig. 84. If the engine cannot be switched off, carry out the emergency switch-off procedure → page 101.
- Follow the instructions in the instrument cluster → page 13.

Warning before leaving the vehicle

Vehicles with an automatic gearbox: If the selector lever is not in position **P**, an acoustic warning signal will sound when the driver door is opened and the warning message **Please move the selector lever to P gear!** will appear on the instrument cluster display. This warns you that the vehicle could potentially roll away. When leaving the vehicle, always switch on the electronic parking brake to prevent the vehicle from rolling away.

WARNING

Never switch off the engine while the vehicle is in motion. Otherwise, it may cause loss of control over the vehicle, accidents and serious or fatal injuries.

- The airbags and belt tensioners do not function when the ignition is switched off.
- The brake booster does not work after the ignition is switched off and you need to apply more force to depress the brake pedal to stop the vehicle.
- When the ignition is switched off, the steering system does not work and you need to apply more force to steer the vehicle.

- When the vehicle key is removed from the ignition, the steering lock may activate and you will no longer be able to steer the vehicle.

WARNING

The components of the exhaust system become very hot and can lead to a fire and cause serious or fatal injuries.

- Always park the vehicle so that no part of the exhaust system can come into contact with highly flammable materials underneath the vehicle (e.g. undergrowth, leaves, dry grass or spilled fuel).
- Never apply additional underseal or anti-corrosion coatings to the exhaust pipes, catalytic converters, heat shields or particulate filter.

NOTICE

If the vehicle has been driven at high load for a long period, the engine can overheat when it is switched off. Allow the engine to run in neutral for approximately 2 minutes before switching it off.

 In vehicles with an automatic gearbox, vehicle key can only be removed from the ignition lock if the selector lever is in position **P**.

 After the engine has been switched off, the radiator fan in the engine compartment may run on for a few minutes. The radiator fan will switch itself off automatically.

Electronic immobiliser

The immobiliser helps to prevent the engine from being started and driven with an unauthorised vehicle key.

A valid vehicle key contains an electronic chip. When a valid vehicle key is inserted in the ignition lock, the electronic immobiliser will be deactivated automatically.

The electronic immobiliser is automatically activated when the vehicle key is removed from the ignition lock. In vehicles with Keyless Access, the electronic immobiliser is activated automatically when a valid vehicle key is located outside the vehicle only.

The engine can only be started using a genuine Volkswagen vehicle key with the correct code. Coded vehicle keys are available from a Volkswagen dealership.

 The vehicle cannot be operated properly if you do not have a genuine Volkswagen key. <

Troubleshooting

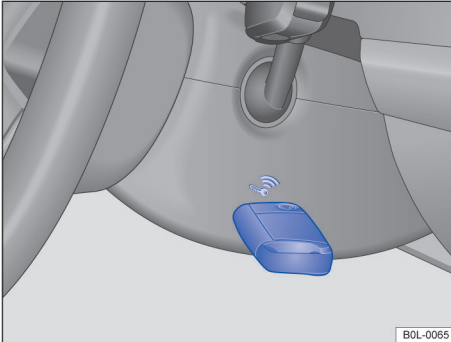

Fig. 85 On the right side of the steering column: emergency start function in vehicle with Keyless Access

EPC Fault in engine management system

The indicator lamp lights up yellow.

Fault in engine management system.

- Have the engine checked immediately by a suitably qualified workshop. Volkswagen recommends using a Volkswagen dealership.

Vehicle key cannot be removed from the ignition lock

An unauthorised vehicle key has been inserted in the ignition lock.

Remove the vehicle key as follows:

Vehicles with an automatic gearbox

- Press the lock button in the selector lever and release.
- Remove the vehicle key from the ignition lock.

Vehicles with a manual gearbox:

- Remove the vehicle key from the ignition lock.

No valid vehicle key recognised

A corresponding message will be displayed in the instrument cluster.

If the button cell in the vehicle key is weak or discharged, it is possible that the vehicle key will not be recognised.

In this case it is necessary to perform an emergency start:

- Depress and hold the brake pedal.
- Hold the vehicle key to the right of the steering column trim directly after pressing the starter button → Fig. 85.
- The ignition is switched on automatically, and in some cases the engine is started.

Engine cannot be switched off

The engine cannot be switched off by briefly pressing the starter button.

In this case, it is necessary to perform an emergency switch-off procedure:

- Press the starter button twice within a few seconds or press and hold once.

The motor switches off automatically →  in *Starter button* on page 98.

Engine cannot be started

A corresponding message will be displayed in the instrument cluster if an unauthorised vehicle key is used or there is a system fault.

- Use an authorized vehicle key.
- If the fault persists, seek expert assistance. <

Start/stop system

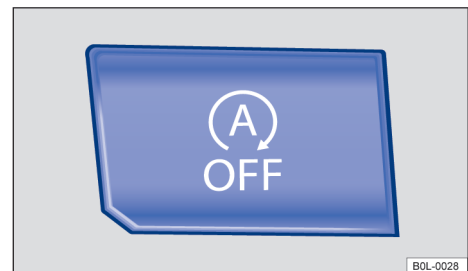

Fig. 86 In the upper part of the centre console: button for the start/stop system.

The start/stop system automatically switches the engine off when the vehicle is coming to a stop and when stationary. When required, the engine restarts automatically. ▶

Switching on the start/stop system

The function is automatically activated every time the ignition is switched on. The instrument cluster display will show information about the current status.

Always switch off the automatic engine start/stop system when driving through water.

Indicator lamps

If the indicator lamp  lights up, the start/stop system is available and automatic engine stop is active.

If the indicator lamp  lights up, the start/stop system is not available or the start/stop system has started the engine automatically → page 102.

The display on the instrument cluster may show the status of the start/stop system.

Vehicles with a manual gearbox:

- Disengage the gear and release the clutch pedal when the vehicle is coming to a stop, or when it is stationary. The engine stops.
- Depress the clutch pedal to restart the engine.

Vehicles with an automatic gearbox

- To stop, press and hold the brake pedal when the vehicle is stationary.
- To restart the engine, take your foot off the brake pedal or depress the accelerator.

Important preconditions for automatic engine switch-off

- The driver is wearing the seat belt.
- The driver door is closed.
- The bonnet is closed.
- A minimum engine temperature has been reached.
- *Vehicles with Climatronix*: the temperature of the vehicle interior is within the preset temperature range, and the humidity level is not too high.
- The defrost function of the air conditioning system is not switched on.
- The charge level of the 12-volt vehicle battery is sufficient.
- The temperature of the 12-volt vehicle battery is not too low or too high.
- The vehicle is not on a steep incline.
- *Vehicles with an automatic gearbox*: the steering wheel is not turned too sharply.

- The window heater is not switched on.
- Reverse gear is not engaged.
- The outside temperature is neither too high nor too low.

The engine may automatically switch off when the vehicle is stationary if the conditions for automatic engine switch-off are met, e.g. if the defrost function is switched off.

Conditions for automatic restart

The engine can start automatically under the following conditions:

- If the temperature inside the vehicle greatly increases or decreases.
- If the vehicle starts rolling.
- If the electric voltage of the 12-volt vehicle battery drops.
- If the steering wheel is moved.



As a general rule, the engine always starts again automatically when required by the detected situation and the vehicle.

Conditions that require a manual engine start

The engine must be started manually in the following conditions:

- If the driver door is opened.
- If the bonnet is opened.

Activating and deactivating the start/stop system manually

- Press the button  → Fig. 86 in the centre console to deactivate the system manually. If the start/stop system has been deactivated, the indicator lamp in the button lights up.
- Press the button  → Fig. 86 in the centre console again to activate the system manually again.

The instrument cluster shows the status of the start/stop system every time the button  is pressed.

If the start/stop system has switched off the engine, the engine will start again as soon as the system is deactivated with the button .

Always switch off the automatic engine start/stop system when driving through water. ▶

Start-Stop mode with automatic Adaptive Cruise Control (ACC)

The engine will be switched off after the ACC has brought the vehicle to a standstill via an active braking intervention → page 113.

In the following instances, the engine will restart when the ACC is active:

- If the accelerator is depressed.
- When the ACC has resumed speed and distance control.
- If the vehicle ahead has moved on.

⚠ WARNING

Never switch off the engine or ignition while the vehicle is in motion. Otherwise, it may cause loss of control over the vehicle, accidents and serious or fatal injuries.

- The airbags and belt tensioners do not function when the ignition is switched off.
- The brake booster does not work after the ignition is switched off and you need to apply more force to depress the brake pedal to stop the vehicle.
- The brake booster does not work after the engine is switched off and you need to apply more force to steer the vehicle.
- When the ignition is switched off, the steering lock may activate and you will no longer be able to steer the vehicle.
- Always deactivate the start/stop system when working in the engine compartment.

ⓘ NOTICE

If the start/stop system is used in very high outside temperatures over a long period, the 12-volt vehicle battery can be damaged.

i The engine stop function may be deactivated automatically if the temperature is above around 38°C.

i In some cases, it may be necessary to restart the engine manually. Follow any corresponding messages on the instrument cluster display.

i Always deactivate the start/stop system manually when driving through water. ◀

Troubleshooting

Engine no longer starts automatically

Vehicles with an automatic gearbox: If the engine does not start automatically, the instrument cluster shows a warning message **Fault: Vehicle Energy System. Please go to the maintenance station.**

- Start the engine manually → page 99.
- Deactivating the start/stop system manually.
- In this case, go to a correspondingly qualified workshop and have the system checked. Volkswagen recommends using a Volkswagen dealership. ▶

Manual gearbox: Selecting a gear

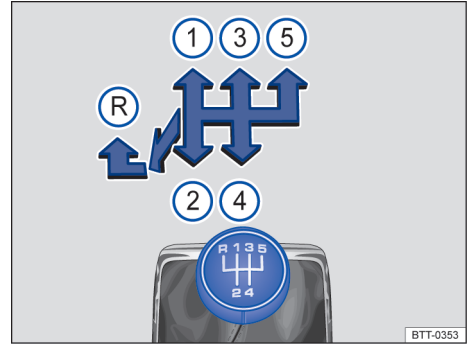

Fig. 87 Gear shift pattern of a 5-speed manual gearbox.

Selecting a forward gear

The positions of the individual gears are displayed on the gear lever → Fig. 87.

- Fully depress and hold the clutch pedal.
- Move the gear lever to the required position → **⚠**.
- Release pedal to engage the clutch.
- Depending on the vehicle, the clutch pedal will have to be depressed fully in order to start the engine. ▶

Selecting reverse gear

- Reverse gear should be selected only when the vehicle is stationary.
- Fully depress and hold the clutch pedal for a few seconds → ⚠.
- Move the gear lever to the neutral position and push down.
- Push the gear lever fully to the left and then forwards into the reverse gear position (R).
- Release pedal to engage the clutch.

Shifting down

Shifting down while driving should always be done one gear at a time to the next lower gear and not at high engine speed → ⚠. At high speeds or high engine speeds, damage to the clutch and the gearbox could occur if one or more gears are skipped when shifting down, even if the clutch is not released when doing this → ⓘ.

⚠ WARNING

Fast acceleration can lead to a loss of traction and skidding on slippery roads. This can cause you to lose control of the vehicle and lead to accidents and serious or fatal injuries.

- Accelerate quickly only if visibility, weather, road and traffic conditions permit, and other road users are not put at risk due to the acceleration and driving style.
- Always adapt your driving style to the traffic.
- Switching off ASR while driving on slippery roads may result in the drive wheels skidding, potentially causing the vehicle to lose steering or become difficult to control.

⚠ WARNING

When a gear is engaged and the clutch pedal released, the vehicle will start moving immediately if the engine is running. The vehicle will start moving even if the electronic parking brake has been switched on.

- Never engage reverse gear while the vehicle is in motion.

⚠ WARNING

An accidentally engaged lower gear may cause loss of control over the vehicle, accidents, and serious or fatal injuries.

ⓘ NOTICE

Serious damage to the clutch and gearbox could occur if the gear lever is shifted to a gear that is too low or if the clutch pedal is pressed and held and the clutch not engaged when travelling at high speeds or at high engine speeds.

ⓘ NOTICE

To avoid damage and premature wear, pay attention to the following:

- Do not rest your hand on the gear lever when driving. The pressure from your hand is passed onto the selector forks in the gearbox.
- Ensure that the vehicle has come to a full stop before engaging reverse gear.
- Always fully depress the clutch pedal when changing gear.
- Do not hold the vehicle by "riding" the clutch on uphill gradients with the engine running.



Changing up a gear early will help to save fuel and minimise engine noise.



Automatic gearbox

Automatic gearbox: Selecting a gear

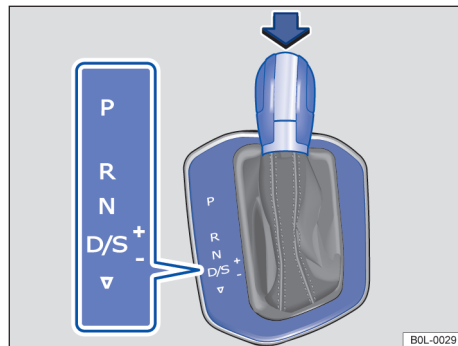

Fig. 88 Selector lever for automatic gearbox with lock button (arrow)

The selected selector lever position will be shown in the instrument cluster display when the ignition is switched on.

P-- Parking lock

The drive wheels are blocked. May only *be selected* when the vehicle is stationary. To disengage this selector lever position, depress the brake pedal and switch on the ignition.

R-- Reverse gear

Move the selector lever to this position when reversing. May only *be selected* when the vehicle is stationary.

N-- Neutral

When the selector lever is moved to this position, the gearbox is not engaged in any gear. No force is transmitted to the wheels and the braking effect of the engine is not available.

D/S-- Forward gear

Position D: Normal mode.

All forward gears are shifted up and down automatically. The timing of the gear shift is determined by the engine load, your individual driving style and the speed of the vehicle.

Position S: Sport mode.

The forward gears are automatically shifted up later and down earlier than in selector lever position **D**. This exploits the engine's full power reserves. The timing of the gear shift is determined by the engine load, your individual driving style and the speed of the vehicle.

To change between positions **D** and **S**, tap the selector lever from **D/S** to *the rear* ▽ → Fig. 88.

The selector lever will always move back into selector lever position **D/S**. This also functions in the Tiptronic gate → page 106.

Selector lever lock

The selector lever lock in position **P** or **N** prevents a gear selector position from being engaged inadvertently and the vehicle being set in motion unintentionally as a result.

To release the selector lever lock, switch on the ignition and depress the brake pedal. Then press the lock button in the selector lever handle in the direction of the arrow → Fig. 88.

The selector lever lock is not engaged if the position **N** is skipped, for example when shifting from **R** to **D** the selector lever lock is not engaged. This makes it possible, for instance, to "rock" the vehicle backwards and forwards to free the vehicle if it is stuck in snow or mud. The selector lever

lock engages if the brake pedal is not depressed and the lever is in position **N** for more than approximately 1 second and the vehicle is travelling no faster than around 5 km/h.

WARNING

Always select the appropriate selector lever position based on the actual situation. Selecting the wrong position can cause you to lose control of the vehicle and lead to accidents and serious or fatal injuries.

- Never depress the accelerator when selecting a position.
- The vehicle will start moving if the brake pedal is released when the engine is running and a position is engaged.
- Never select reverse gear or engage the parking lock **P** when the vehicle is in motion.

WARNING

Unintentional vehicle movements may cause accidents and serious or fatal injuries.

- The driver must never leave the driver seat when the engine is running and a position has been selected. Always switch on the electronic parking brake and move the selector lever to position **P** if it is necessary to leave the vehicle. **P**.
- Hold the vehicle by the foot brake if the engine is running and the position **D**, **S** or **R** is engaged. Otherwise, the vehicle will creep forward because the power transmission system is not completely disconnected while the engine is idling.
- Never select reverse gear **R** or **P**.
- Never leave the vehicle on uphill gradients in selector lever position **N**, as the vehicle will roll downhill even if the engine is switched on.

NOTICE

If the electronic parking brake is **not** switch on the electronic parking brake and move the selector lever to position **P**. **P** is engaged, the vehicle may move a few centimetres forwards or backwards.

i If the selector lever is accidentally moved to **N** when driving, take your foot off the accelerator. Wait for the engine to reach idling speed in the neutral position before selecting a position again. ▶

i If the selector lever is not left in the parking lock position **P** for long periods when the engine is switched off, the 12-volt vehicle battery will discharge.

Changing gear using Tiptronic

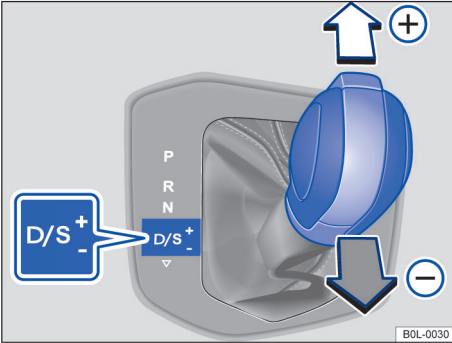

Fig. 89 Selector lever in Tiptronic position

Using Tiptronic, the gears can be shifted up and down manually in an automatic gearbox.

The gear that is currently selected will be maintained when the Tiptronic mode is selected. This remains the case as long as the system does not automatically carry out a change of gear due to the current driving situation.

Operating Tiptronic with the selector lever

- Push the selector lever from position **D/S** to the right into the Tiptronic gate.
- Tap the selector lever forwards **+** or back **-** to shift gear up or down → [Fig. 89](#).

When tapping the selector lever in the Tiptronic gate, it is not necessary to press the lock button on the selector lever.

! NOTICE

- When accelerating, the gearbox automatically shifts up to the next gear shortly before the maximum permitted engine speed is reached.
- When shifting down a gear manually, the gearbox will not change gear until the engine can no longer be overdriven.

Driving with DSG® dual clutch gear box

◀ The forward gear will automatically shift up or down.

Driving down hills

The steeper the downhill gradient, the lower the gear that must be selected. Lower gears increase the braking effect of the engine. Never allow the vehicle to roll down mountains or hills in the neutral position **N**.

- Reduce your speed.
- Push the selector lever from position **D/S** to the right into the Tiptronic gate → [page 106](#).
- Tap the selector lever to the rear to change down gear.

Stopping and pulling away on uphill gradients

The steeper the incline, the lower the gear that is required.

If you wish to stop the vehicle or pull away when driving uphill you should use the Auto Hold function. → [page 123](#)

When you stop the vehicle on an uphill gradient with a selected position, the vehicle must always be prevented from rolling by depressing the brake pedal or by applying the electronic parking brake. Do not release the brake pedal or switch off the electronic parking brake until you pull away.

Kickdown function

The kickdown function enables maximum acceleration in the selector lever position **D/S** or in the Tiptronic position.

If the accelerator is depressed fully, the gearbox will automatically shift to a lower gear, depending on the speed and engine speed. This will make use of the full vehicle acceleration.

With the kickdown function, the gearbox does not shift up to the next gear until the engine reaches the maximum engine speed for the current gear.

! WARNING

Fast acceleration can lead to a loss of traction and skidding on slippery roads. This can cause you to lose control of the vehicle and lead to accidents and serious or fatal injuries. ▶

- Always adapt your driving style to the traffic.
- Use the kickdown function or fast acceleration only if visibility, weather, road and traffic conditions permit, and other road users are not put at risk due to the acceleration and driving style.

⚠ WARNING

“Continuously depress” the brake pedal or frequently apply foot brake will cause the brakes to overheat. This can considerably reduce the braking effect, increase the braking distance and, in certain circumstances, cause the brake system to fail completely.

ⓘ NOTICE

- If you stop the vehicle on an incline while a position is selected, do not attempt to stop it from rolling back by depressing the accelerator. This could cause the automatic gearbox to overheat or be damaged.
- Never allow the vehicle to roll in selector lever position N, particularly if the engine is switched off. This could cause damage to the automatic gearbox due to lack of lubrication.

ⓘ NOTICE

- Never let the brakes “rub” by applying light pressure to the brake when it is not necessary to brake.

Troubleshooting

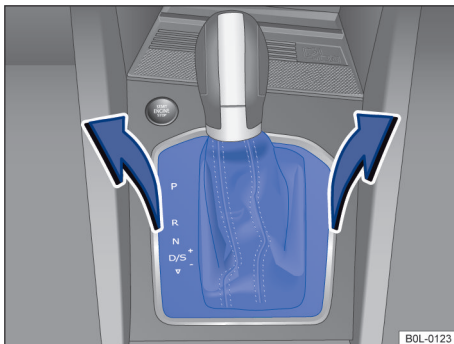

Fig. 90 Removing the cover of the gearshift gate

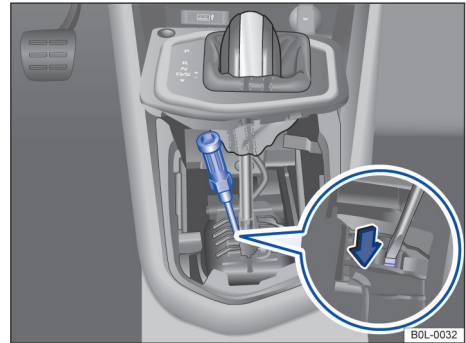

Fig. 91 Releasing the selector lever lock manually

ⓘ Engine does not start

The indicator lamp lights up green.

Brake pedal was not depressed, e.g. when trying to engage another position with the selector lever.

- To select a position, depress the brake pedal → page 91.
- Refer to the parking brake as well → page 123.

ⓘ Lock button prevents you from driving off

The indicator lamp flashes green.

The lock button in the selector lever is not engaged.

- Press the lock button to engage the selector lever lock.

ⓘ Selector lever lock prevents you from driving off

The indicator lamp flashes green. An information text is additionally displayed.

In rare cases, the selector lever lock may not engage in vehicles with an automatic gearbox.

The drive is then deactivated to prevent the vehicle from accidentally pulling away.

- Depress the foot brake and then release it again.

Releasing the selector lever lock manually

If the power fails in the vehicle, e.g. due to a flat 12-volt vehicle battery, and the vehicle has to be pushed or towed, the selector lever lock must be released manually. Seek expert assistance.

The manual release mechanism is located under the cover of the gearshift gate.

Removing the cover of the gearshift gate:

- Switch on the electronic parking brake. If the electronic parking brake cannot be switched on, the vehicle will have to be prevented from rolling off using other means.
- Switch off the ignition.
- Carefully pull the cover upwards in the area around the selector lever gaiter with connected electrical wiring → Fig. 90.
- Pull the cover up and over the selector lever → .

Releasing the selector lever lock manually:

- Insert the screwdriver head into the slot of the manual release mechanism, and slightly press the manual release mechanism in the direction of the arrow → Fig. 90.
- Press the lock button on the front of the selector lever handle and move the selector lever into position **N**.
- After manual unlocking, carefully press the cover into the centre console while ensuring that the electrical wires are positioned correctly.

Emergency mode

There is a fault in the system if all the displays on the instrument cluster for the selector lever positions have a light background. The automatic gearbox is running in an emergency mode. The vehicle can still be driven in the emergency mode, but only at reduced speed and not in all gears.

In vehicles with an automatic gearbox, you may **no longer be able to select reverse gear**.

In all cases, you should have the automatic gearbox checked immediately by a suitably qualified workshop. Volkswagen recommends using a Volkswagen dealership.

Vehicle does not move even though position is engaged

If the vehicle will not move in the required direction, the system may have selected the position incorrectly.

- Depress the brake pedal and reselect the position.
- If the vehicle still does not move in the required direction, there is a system fault. Seek expert assistance and have the system checked.

WARNING

Do not move the selector lever out of position **P** without the electronic parking brake on. **P** while the electronic parking brake is switched off. Otherwise, the vehicle can start moving unexpectedly when on uphill and downhill gradients. This can lead to accidents and serious injuries.

NOTICE

If the vehicle rolls for an extended period or at high speed with the engine switched off and with the selector lever in the position **N**, the automatic gearbox will be damaged. 

Steering

Information on steering

The steering should be locked every time you leave the vehicle to make it more difficult for the vehicle to be stolen.

The steering

The power steering of this vehicle is not a hydraulic mechanism, but an electromechanical system. One of the major advantages of this system is that it eliminates the need for hydraulic oil pipes, hydraulic oil, hydraulic pumps, filters, and other hydraulic components, and is more energy-efficient. Compared with hydraulic power steering systems that require constant pressure, the electromechanical system only requires energy when actual steering is performed, consuming energy only as needed, thereby reducing fuel consumption.

Electronic steering lock in vehicles with a starter button

Switch off the ignition and then open the driver door, the steering column is locked. The vehicle must be stationary. If necessary, move the selector lever to position **P**.

If the driver door is opened first and then the ignition switch is turned off, the electronic steering column lock will be activated only after the vehicle is locked using the door handle sensor or the vehicle key, and the steering will be locked. 

Mechanical steering column lock in vehicles with an ignition lock

Remove the key from the ignition when the vehicle is stationary and the steering column will be locked. Slightly turn the steering wheel until the steering lock clicks into place.

To unlock the steering column lock, insert the vehicle key into the ignition and turn the steering wheel slightly to release the steering column lock. Hold the steering wheel in this position and switch on the ignition.

Electromechanical steering system

The power steering provided by the electromechanical steering system automatically adjusts to the vehicle speed, steering torque, and steering angle of the wheels. The electromechanical steering only functions when the engine is running.

You will need considerably more strength than normal to steer the vehicle if the power steering is reduced or has failed completely.

Reverse steering assist function

The reverse steering assist function can provide the driver with reverse steering assistance in emergency situations, thus stabilizing the vehicle → ⚠.

WARNING

If the power steering is not working, the steerability of the vehicle will be significantly reduced due to a stiff steering wheel. This can lead to a loss of vehicle control, accidents, serious injuries and death.

- The power steering system only works when the engine is running.
- Never allow the vehicle to roll if the engine is switched off.
- Never remove the key from the ignition lock while the vehicle is in motion. Otherwise, the steering lock may engage and you will no longer be able to steer the vehicle. This can result in accidents and serious or even fatal injuries.

WARNING

In conjunction with ESC, the reverse steering assist function provides driver support during critical steering situations. However, the driver

must always actively apply steering to the vehicle, as the reverse steering assist function will not steer the vehicle.

NOTICE

To prevent the steering wheel from locking and to ensure that the turn signals, horn, wipers, and window washer are working properly when towing the vehicle, keep the ignition switch on. <

Troubleshooting

Steering fault

The warning lamp flashes red.

There is a fault in the electronic steering lock.

-  **Do not drive on!** Seek expert assistance.
- If the warning lamp **lights up** red, the steering may be stiff because the electromechanical steering has failed.
- If the warning lamp **flashes** red, it is not possible to unlock the steering column.

Steering fault

The indicator lamp lights up or flashes yellow.

The steering is harder or more sensitive than usual.

The indicator lamp **lights up continuously**:

- Restart the engine and drive a short distance slowly.
- If the warning lamp stays lit, the system should be checked by a suitably qualified workshop. Volkswagen recommends using a Volkswagen dealership.

The indicator lamp **flashes**:

- Turn the steering wheel to and fro.
- Switch the ignition off and then on again.
- Observe the messages on the instrument cluster display.
- Do not continue your journey if the indicator lamp still flashes after the ignition is switched on. Seek expert assistance. <

Driver assist systems

General description

WARNING

The radar sensor installed on the vehicle may be subjected to harmful interference from the external environment (including but not limited to rain, snow, hail, freezing, haze and other weather factors as well as the same or similar frequency band automotive radar, etc.) during the working process.

- If the radar sensor is interfered with, it may cause signal distortion and result in abnormal operation of related systems (including but not limited to the infotainment system/instrument cluster warning, adaptive cruise control system/area monitoring system). In this case, the driver should immediately take control of the vehicle and operate it manually to ensure driving safety.

Cruise control system (GRA)

Introduction

This chapter contains information on the following subjects:

- Operating the GRA system 111
- Troubleshooting 111

The cruise control system (GRA) maintains a constant speed that you have set

The GRA is available when driving forwards at speeds from around 30 km/h.

Driving with GRA

The driver can overtake other vehicles at any time at speeds higher than the stored speed. The GRA control is temporarily suspended during acceleration, but resumes at the stored speed once acceleration is complete.

How to operate GRA?

Depending on the vehicle equipment, GRA can be operated through the turn signal lever
→ page 111.

Displays

When GRA is switched on, the instrument cluster display shows the stored speed and the status of GRA:



Small font or gray: GRA is deactivated.

Large font or white: GRA is activated.

If no speed has been stored, the instrument cluster display will show --- instead of the speed.

Driving downhill

The vehicle speed may exceed the stored speed during driving downhill.

To reduce the speed, the foot brake should be applied and if necessary, shift to a lower gear.

WARNING

Never use GRA to maintain a constant speed if traffic conditions do not allow for a safe following distance. This can lead to accidents and serious injuries.

- For safety reasons, never use GRA in areas with heavy traffic, multiple curves, inclines, or slippery surfaces (such as snowy, wet, or flooded roads), as well as on gravel or flooded roads.
- Never use GRA when driving on unpaved areas or dirt roads.
- Adapt your speed and distance from the vehicles ahead to suit visibility, weather, road, and traffic conditions.
- Switch off the GRA immediately after use to avoid accidents caused by unintentional use.
- Set a reasonable cruise speed that is appropriate for the weather, road and traffic conditions. Failing to do so could result in accidents and serious or fatal injuries.
- When driving downhill, GRA may not be able to maintain the set cruise speed, and the vehicle may accelerate due to its own weight. In this case, shift to a lower gear or apply the foot brake immediately to reduce speed.

Operating the GRA system

📖 Please refer to ⚠️ at the start of the chapter on page 110.

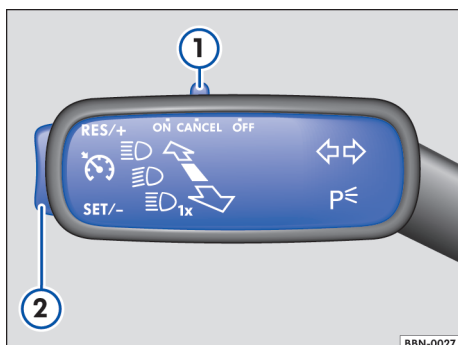

Fig. 92 Left side of the steering column: GRA operation buttons

Open

- Push switch → Fig. 92 ① into position **ON**.

The cruise speed has not been stored or controlled.

Starting control

- While driving, press the **SET/-** ② button.

The current vehicle speed has been stored as the cruise speed, and the system is controlling accordingly.

The green indicator lamp (🟢) lights up.

Adjusting the speed

In the GRA control process, you can set the stored speed by ② buttons:

RES/+ + 1 km/h

SET/- - 1 km/h

Press and hold the **RES/+**/**SET/-** ② button to continuously change the stored speed. The vehicle controls the speed by accelerating or reducing fuel. The vehicle will not slow down automatically.

Cancelling control

- Push switch ① into position **CANCEL** or depress the brake pedal.

The speed remains stored in the memory.

Resuming control

- Press the button ② in **RES/+**.

The system controls the vehicle speed according to the stored speed.

Switching off

- Push switch ① into position **OFF**.

The GRA is switched off and the set speed is deleted. <

Troubleshooting

📖 Please refer to ⚠️ at the start of the chapter on page 110.

! GRA fault

- Seek expert assistance and have the system checked.

Control is interrupted automatically

- The vehicle is travelling at a higher speed than the stored speed for an extended period.
- The selector lever is not in position **D/S**.
- Brake assist systems such as ASR or ESC have controlled the vehicle.
- The vehicle was braked by the area monitoring system (front assist) or the autonomous emergency braking function → page 118.
- If the problem persists, switch off GRA and go to a correspondingly qualified workshop. Volkswagen recommends using a Volkswagen dealership. <

Speed limiter

📖 Introduction

This chapter contains information on the following subjects:

- Operating the speed limiter through the multifunction steering wheel 112
- Troubleshooting 113 ▶

The speed limiter helps to prevent the vehicle from exceeding a speed that you have stored.

The speed limiter is available when driving forwards at speeds from around 30 km/h.

Interrupt the speed limiter while driving

You can interrupt the speed limiter function at any time by fully depressing the accelerator beyond the point of resistance. As soon as the stored speed is exceeded, the green indicator lamp (🟢) will flash and an acoustic warning may sound. The speed remains stored in the memory.

The speed limiter function is activated again automatically as soon as the speed drops below the stored speed.

Displays

When the speed limiter is switched on, the instrument cluster display shows the stored speed and the status of the speed limiter:

 Small font or gray: the speed limiter is deactivated.

Large font or white: the speed limiter is activated.

Driving downhill

The vehicle cannot maintain the stored speed in all driving situations.

To reduce the speed, the foot brake should be applied and if necessary, shift to a lower gear.

WARNING

In order to avoid unintentional control interventions, switch off the speed limiter when you do not need it.

- Even if the vehicle is equipped with a speed limiter, the driver must control the vehicle speed according to the actual situation. Do not drive at full throttle if this is not necessary.
- It is extremely dangerous to use a speed limiter in inclement weather conditions. Serious injury or death may occur when driving on roads with water, snow, ice or leaves. Use speed limiter only when road and weather conditions permit.

- When driving downhill, the speed limiter may not be able to maintain the set speed, and the vehicle may accelerate due to its own weight. In this case, shift to a lower gear or apply the foot brake immediately to reduce speed.

Operating the speed limiter through the multifunction steering wheel



 Please refer to  at the start of the chapter on page 112.



Fig. 93 left side of the multifunction steering wheel: speed limiter operation buttons

Open

- Press the  button.

The previously set speed is stored in the system but control has not started yet.





Starting control



- While driving, press the  button.

The current speed is stored as the maximum speed. The green indicator lamp (🟢) lights up.

Adjusting the speed

You can adjust the stored speed:

-  +1 km/h
-  -1 km/h
-  +10 km/h
-  -10 km/h

Press and hold the  or  button to continuously change the stored speed.

Cancelling control

- Press the  button.

The speed remains stored in the memory.

Resuming control

- Press the  button.



Once the speed drops below the stored speed, the speed limiter will be reactivated.

Close



- Press and hold the  button.

The speed limiter is switched off and the saved speed is deleted (even if the ignition is switched off).

Switch to Adaptive Cruise Control (ACC)

- Long press the button  to switch off the speed limiter.
- Press the  button.

Troubleshooting

 Please refer to  at the start of the chapter on page 112.

Control is interrupted automatically

Fault or malfunction.

- Switch off and restart the engine.
- If the problem persists, switch off the speed limiter and go to a correspondingly qualified workshop. Volkswagen recommends using a Volkswagen dealership.

For safety reasons, the speed limiter switches itself off completely only when you release the accelerator once or switch off the system manually. <

Adaptive Cruise Control (ACC)

Introduction

This chapter contains information on the following subjects:

- Special driving situations 114
- System limits of ACC 114
- Switching the ACC on and off 116

- Setting the ACC 116
- Troubleshooting 117

The Adaptive Cruise Control (ACC) maintains a constant speed that you have set. If the vehicle approaches a vehicle in front, the ACC automatically adapts the speed so that a distance you have selected is maintained.

You can set a speed between around 30 km/h and around 150 km/h. Depending on equipment level, there may be slight deviations in the speed range.

Driving with ACC

- < You can override the active ACC system at any time. Control will be stopped if you brake. If you accelerate, control will be interrupted while you are accelerating and then resumed with the set speed.

Whether the vehicle is equipped with ACC

The vehicle is equipped with ACC if you can adjust settings for ACC in the instrument cluster menu → page 116.

Driver intervention prompt

-  The red warning lamp on the instrument cluster lights up and an acoustic warning is given. As automatic deceleration by the ACC system is not sufficient or the system limits have been reached, the ACC system will request you to take over control of the vehicle and be prepared to brake.

Radar sensor

ACC detects driving situations by means of the radar sensors in the front of the vehicle → page 5.

The range of the radar sensor is up to approximately 160 m.

WARNING

The adaptive cruise control system (ACC) cannot replace the driver's attention and operates only within the limits of the system. Improper >

or careless use of ACC can easily lead to accidents and serious injuries. If you do not pay due attention, there is a risk of accidents and serious or even fatal injuries.

- Adapt your speed and distance from the vehicles ahead to suit visibility, weather, road, and traffic conditions.
- For safety reasons, never use ACC in low visibility conditions, on roads with multiple curves, inclines, or slippery surfaces (such as snowy, wet, or flooded roads).
- Never use ACC during off-road driving or on unpaved roads. ACC can only be used on paved roads.
- Depending on vehicle equipment, ACC may not respond to stationary vehicles.
- ACC will not react to persons, animals, or vehicles that are crossing laterally or approaching the vehicle in the same lane.
- If sufficient deceleration is not possible through ACC, the driver shall immediately apply foot brake as required by the system.
- Foot brake should be applied as soon as braking requirement information is displayed on the instrument cluster display.
- If the system requests the driver to take control of the vehicle and the vehicle continues to move, the driver must apply the foot brake.
- Always be prepared to take control of the vehicle by accelerating or braking yourself.

⚠ WARNING

Never take risks by using the additional convenience features provided by the adaptive cruise control (ACC). ACC cannot detect all driving situations and may not react or may react with a delay or in an undesired way. Drivers are responsible for all driving behaviors at all times.

- Pay attention to changes in road conditions and drive with caution when using the ACC. Failure to do so may lead to accidents and serious or fatal injuries.
- The ACC can only work within its maximum range when the radar sensors detect a vehicle in front. Under special circumstances, the system may not issue a warning or intervene immediately or may issue a warning or intervene with a delay. In this case, you should

use the brakes and take control of the vehicle as needed to avoid accidents and serious or fatal injuries.

- Even if the system is functioning properly, the conditions of the vehicle detected by the system may not match the driver's observations. If you do not pay due attention, there is a risk of accidents and serious or even fatal injuries.

Special driving situations

📖 Please refer to **⚠** at the start of the chapter on page 113.

Overtaking

If you indicate left to overtake, ACC will accelerate the vehicle and reduce the distance from the vehicle in front. Your set speed will not be exceeded.

If ACC does not detect any vehicle in front after you have changed lane, ACC will accelerate the vehicle up to the set speed.

System limits of ACC

📖 Please refer to **⚠** at the start of the chapter on page 113.

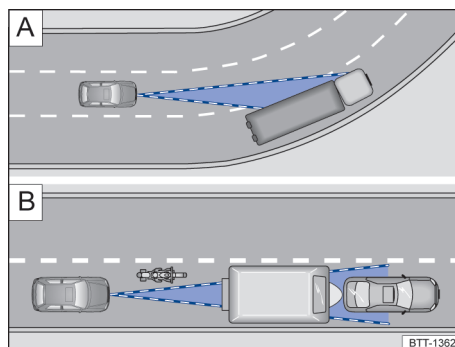

Fig. 94 **A** Driving through bends. **B** Vehicle that is driving outside the sensor range

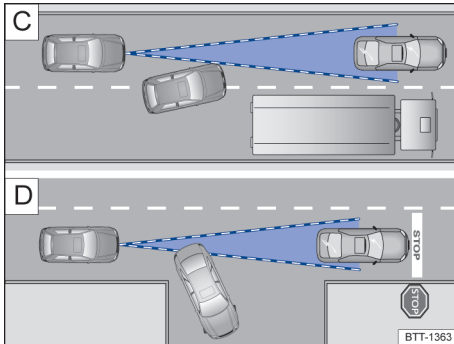

Fig. 95 [C] Vehicle that is changing lane. [D] Vehicle that is turning or stationary

Limits of the ACC

ACC should be interrupted in the following driving conditions due to system limitations → ⚠ in *Introduction* on page 113:

- Driving in poor weather conditions, e.g. heavy rain, snow or heavy spray.
- Driving through road works, tunnels or toll stations.
- Driving through road works, tunnels or toll stations.
- Driving in the parking lot.
- Driving on roads with embedded metal objects, e.g. railway tracks.
- Driving on roads with loose chippings.
- Driving on a multi-lane road when other vehicles are travelling at a lower speed in the overtaking lane.
- After external force on components in the area of the radar sensors, e.g. after a rear-end collision.

Delayed response of ACC

If the sensor system is exposed to environmental conditions that impair sensor functioning, the driver assist systems may detect this only after a certain delay. For this reason, any restrictions to functions may be displayed only after a delay at the start of the journey and when driving → ⚠ in *Introduction* on page 113.

Limits of the sensors:

Radar sensors only recognize vehicles that are driving in the same direction. Objects that cannot be detected:

- Persons.
- Animals.
- stationary vehicles.
- Crossing or oncoming vehicles.
- Other stationary obstacles.

Stationary vehicles

If a vehicle detected by the ACC turns or leaves its lane and there is a stationary vehicle ahead, ACC will not react to the stationary vehicle → Fig. 95[D].

Turning

The radar sensors always detect vehicles in a straight line. Therefore, it may suddenly detect vehicles in sharp turns or not detect vehicles in front → Fig. 94[A].

Vehicles outside the sensor range

ACC may not react or may react with a delay or in an undesired way in the following driving conditions:

- Vehicles driving outside the sensor range and in the vicinity of the vehicle, e.g., motorcycles → Fig. 94[B].
- Vehicles switching from the adjacent lane in front of the vehicle → Fig. 95[C].
- Vehicles with protruding attachments or additions.

⚠ WARNING

Using ACC in the above driving conditions may cause accidents, serious or fatal injuries, and violations of legal requirements. ◀

Switching the ACC on and off

📖 Please refer to ⚠️ at the start of the chapter on page 113.



Fig. 96 Left side of the multifunctional steering wheel: ACC operation buttons

Switching on

- Press the  button.



Indicator  is gray and ACC is not yet performing a control intervention.

Starting control

- While driving forwards, press the  button.

ACC stores the current speed and maintains the set distance. If the current speed is outside the defined speed range, ACC will set the minimum speed when driving more slowly than the limit or the maximum speed when driving faster than the limit.

Depending on the situation, the following warning lamps light up:

-  ACC has taken control.
-  ACC has taken control. No vehicle detected ahead.
-  ACC has taken control. Vehicle detected ahead.

Cancelling control

- Briefly press the  button or depress the brake pedal.

The indicator lamp  lights up gray, and the speed and distance remain stored.

Control is automatically cancelled if Acceleration Slip Regulation (ASR) is activated.

Resuming control

- Press the  button.

ACC adopts the last set speed and last set distance. The instrument cluster display shows the set speed and the indicator lamp  lights up green.

Switching off

- Press and hold the  button.

The set speed is deleted.

Changing to the speed limiter

- Press the button  and select the speed limiter on the instrument cluster display.

ACC is switched off. <

Setting the ACC

📖 Please refer to ⚠️ at the start of the chapter on page 113.



Fig. 97 On the instrument cluster display: set distance (illustration, the ACC is controlling distance).

Setting the distance

You can set the distance in five gears from very small to very large:





- Press the  button repeatedly until the required distance is selected.

The instrument cluster display shows the chosen gear → Fig. 97 ①. Please observe any country-specific regulations for the minimum distance.

If the ACC has not taken control, the set distance and vehicle are not highlighted on the instrument cluster display. ▶

Adjusting the speed

You can adjust the stored speed within the defined speed range by means of the buttons on the multifunction steering wheel:

	+1 km/h
	-1 km/h
	+10 km/h
	-10 km/h



Press and hold the corresponding button to continuously change the stored speed.

WARNING

If you do not maintain the minimum distance to the vehicle in front or if the difference in speed between the vehicle in front and your own vehicle is so great that the braking action of ACC is insufficient, you are in danger of colliding with the vehicle in front. In rainy days and winter road conditions, the braking distance will be extended.

- ACC cannot detect all driving situations correctly.
- Always be prepared to brake the vehicle yourself.
- Press the accelerator to override Adaptive Cruise Control. ACC does not brake automatically in this case.
- Observe any country-specific regulations for the minimum distance.
- Always set a larger distance in wet or snowy conditions or when visibility is poor.

Troubleshooting

 Please refer to  at the start of the chapter on page 113.

!ACC not available

The indicator lamp lights up.

- The radar sensor is dirty. Clean the radar sensor → page 204.
- The view of the radar sensor is impaired due to the weather conditions, e.g. snow, or due to detergent deposits or coatings. Clean the radar sensor → page 204.

- The view of the radar sensor is impaired by add-on parts, number plate holders with trim frames or stickers. Keep the area around the radar sensor free.
- The radar sensor has been displaced or damaged, for example, due to damage to the front end of the vehicle. Check whether damage is visible → page 210.
- Fault or malfunction. Switch off and restart the engine.
- Paint work or structural modifications were carried out on the front of the vehicle.
- The genuine Volkswagen radiator grille is not used.
- If the fault persists, go to a correspondingly qualified workshop. Volkswagen recommends using a Volkswagen dealership.

The ACC does not function as expected

- The radar sensor is dirty. Clean the radar sensor → page 204.
- The system limits have been exceeded → page 114.
- The brakes have overheated, control was cancelled automatically. Allow the brakes to cool down and check their functionality again.
- If the vehicle in front suddenly brakes in an emergency, the ACC may not respond. In this case, the driver should brake accordingly and take control of the vehicle.
- If the fault persists, go to a correspondingly qualified workshop. Volkswagen recommends using a Volkswagen dealership.

Control cannot be started

Make sure that the following conditions are met:

- The selector lever is in position **D/S** or the Tiptronic gate.
- The brake lights on the vehicle are working.
- ESC is not performing a control intervention.
- The brake pedal is not depressed.

Unusual noises during automatic braking

- This is normal and is not a fault.

Adjusting and calibrating the ACC

The ACC must be adjusted and calibrated in the following situations: 

- When the mounting and positioning bracket for the automatic distance control system sensor has been removed and installed.
- When the automatic distance control system sensor has been removed and installed.
- When the front wheel and/or rear axle camber has been adjusted during four-wheel alignment.

Note that specific and specialized tools are required for the adjustment and calibration of the ACC. If the ACC needs to be adjusted or calibrated, go to a correspondingly qualified workshop. Volkswagen recommends using a Volkswagen dealership.

Area monitoring system (Front Assist)

Introduction

This chapter contains information on the following subjects:

- Warning levels and braking intervention 119
- System limits of Front Assist 120
- Pedestrian monitoring system 121
- Operating Front Assist 121
- Troubleshooting 122

The area monitoring system (Front Assist) that includes the autonomous emergency braking function and pedestrian monitoring system can help avoid accidents.

The area monitoring system (Front Assist) can detect imminent frontal collisions and issue corresponding warnings. The system can also assist when braking and initiate automatic braking. The warning times vary depending on the traffic situations and driver behaviour.

Front Assist is not a substitute for the full concentration of the driver.

Driving with Front Assist

You can cancel the automatic braking interventions by steering or pressing the accelerator.

Automatic braking

Front Assist can decelerate the vehicle to a standstill. The vehicle will then not be held permanently. Depress the brake pedal!

If Front Assist is triggered to apply brakes to the vehicle, the brake pedal travel will be shortened. This may make the brake pedal feel "harder" during an automatic braking operation.

Radar sensor

Front Assist detects driving situations by means of the radar sensors in the front of the vehicle → page 5. The range of the radar sensor is up to approximately 160 m.

Functions

Front Assist includes the autonomous emergency braking and pedestrian monitoring functions (depending on vehicle equipment). The functions are automatically active when Front Assist is switched on.

WARNING

Front Assist cannot replace the driver's attention and operates only within the limits of the system. Never take risks by using the additional convenience features provided by Front Assist. Front Assist cannot detect all driving situations and may not react or may react with a delay or in an undesired way. Drivers are responsible for all driving behaviours at all times.

- Adapt your speed and the distance from the vehicles ahead to suit visibility, weather, road and traffic conditions.
- It is important to note that Front Assist cannot detect all objects within the entire speed range → page 120.
- If Front Assist issues a warning, brake your vehicle immediately depending on the traffic situation or avoid the obstacle.
- Front Assist may provide unnecessary warnings and interventions when its functionality is compromised, such as when a malfunction occurs. In this case, drivers should consider cancelling the automatic intervention of Front Assist and be ready to take control of the vehicle.
- Front Assist may provide unnecessary warnings and interventions in complex driving conditions, such as when encountering a safety island.

- If you are unsure about what systems your vehicle has depending on the vehicle equipment, please enquire at a suitably qualified workshop before starting your journey. Volkswagen recommends using a Volkswagen dealership.

Warning levels and braking intervention

📖 Please refer to ⚠️ at the start of the chapter on page 118.

Distance warning

Front Assist detects when safety is endangered by driving too close to the vehicle in front. The indicator lamp  lights up. Increase the distance!

Speed range: around 65 km/h to 250 km/h.

Advance warning

Front Assist detects a possible collision and prepares the vehicle for possible emergency braking. An acoustic warning sounds and the red warning lamp  lights up. Brake or take avoiding action!

For different conditions, **advance warning** may be activated in the following speed ranges:

Advance warning	
Stationary vehicles	Around 30 km/h to 85 km/h ^{a)}
Vehicles driving in the same direction	Around 30 km/h to 250 km/h ^{a)}
Pedestrians walking in the same direction	Around 30 km/h to 65 km/h ^{a)}
Pedestrians crossing the road	Around 30 km/h to 65 km/h ^{a)}

^{a)} This data is an approximate value and only applies under ideal conditions.

Urgent warning

If you do not react to the advance warning, the system may initiate a short braking jolt in order to draw attention to the increasing collision risk. Brake or take avoiding action!

For different conditions, **Urgent warning** may be activated in the following speed ranges:

Urgent warning	
Vehicles driving in the same direction	Around 30 km/h to 250 km/h ^{a)}

^{a)} This data is an approximate value and only applies under ideal conditions.

Automatic braking

Front Assist can brake the vehicle automatically in several stages with increasing braking force. The reduced speed means that it is possible to minimise the consequences of an accident.

For different conditions, **Automatic braking** may be activated in the following speed ranges:

Automatic braking	
Stationary vehicles	Around 5 km/h to 55 km/h ^{a)}
Vehicles driving in the same direction	Around 5 km/h to 250 km/h ^{a)}
Pedestrians walking in the same direction	Around 5 km/h to 65 km/h ^{a)}
Pedestrians crossing the road	Around 5 km/h to 65 km/h ^{a)}

^{a)} This data is an approximate value and only applies under ideal conditions.

Braking intervention

If the system detects that you are braking insufficiently when there is a risk of collision, Front Assist can increase the braking force and help prevent a collision. This can help minimise the consequences of an accident.

For different conditions, **Braking intervention** may be activated in the following speed ranges: ▶

Braking intervention

Stationary vehicles	Around 5 km/h to 85 km/h ^{a)}
Vehicles driving in the same direction	Around 5 km/h to 250 km/h ^{a)}
Pedestrians walking in the same direction	Around 5 km/h to 65 km/h ^{a)}



^{a)} This data is an approximate value and only applies under ideal conditions.



Autonomous emergency braking

Autonomous emergency braking function is an integral part of Front Assist. Front Assist can brake the vehicle automatically in several stages with increasing braking force, without issuing a prior warning.

The red warning lamp  lights up.

System limits of Front Assist

 Please refer to  at the start of the chapter on page 118.

  Front Assist is not available or only partially available for approximately 30 seconds after vehicle start (depending on different driving conditions). Depending on vehicle equipment, the indicator lamp lights up yellow or white in the instrument cluster display during this time. When the indicator lamp lights up white, the warning lamp may also illuminate at the same time .

Front Assist cannot replace the driver's attention and operates only within the limits of the system. Always be prepared to brake the vehicle yourself.

Delayed response

If the sensor system is exposed to environmental conditions that impair sensor functioning, the driver assist systems may detect this only after a certain delay. For this reason, any restrictions to functions may be displayed only after a delay at the start of the journey and when driving  in *Introduction* on page 118.

Objects that cannot be detected

Front Assist may not react or may react with a delay in the case of the following objects:

- Vehicles driving outside the sensor range and in the vicinity of the vehicle, e.g. vehicles or motorcycles ahead.
- Vehicles switching from the adjacent lane in front of the vehicle.
- Vehicles with protruding attachments or additions.
- Oncoming vehicles or vehicles crossing your path.
- Stationary or oncoming pedestrians, or pedestrians moving in the driving direction.
- When pedestrians and cyclists are not detected, for example because they are partially or fully hidden.

Function limitations

Front Assist may not react or may react with a delay in the following conditions:

- Driving at a sharp turn.
- Driving in poor weather conditions, e.g. heavy rain, snow or heavy spray.
- Driving in the parking lot.
- Driving on roads with embedded metal objects, e.g. railway tracks.
- Reversing.
- If ASR is switched off.
- If ESC is performing a control intervention.
- The radar sensor is dirty or covered.
- If several brake lights on the vehicle are faulty.
- If the vehicle accelerates hard or the accelerator is fully depressed.
- In complex driving conditions, e.g. safety island.
- In unclear traffic situations, e.g. vehicles ahead are braking heavily or turning off.
- If there is a fault in Front Assist. 

Switching off Front Assist.



Front Assist is not suitable for use in the following situations due to the limitations of the system and must be switched off → 

- If the vehicle is utilised in a capacity beyond usage on public roads, e.g. off-road or on a race track.
- If the vehicle is being towed or is loaded onto another vehicle.
- If the radar sensor is covered by any auxiliary equipment, e.g. auxiliary headlights.
- If the radar sensor is faulty.
- After external force on components in the area of the radar sensor, e.g. after a rear-end collision.
- In the event of multiple unwanted interventions.

WARNING

If you use Front Assist in the situations mentioned, this can result in accidents and serious injuries or even death.

Pedestrian monitoring system

 Please refer to  at the start of the chapter on page 118.

Pedestrian monitoring system helps to avoid collisions with pedestrians crossing the path or reduce the consequences of collisions.

The pedestrian monitoring system can detect imminent frontal collisions and issue corresponding warnings. The system can also assist when braking and initiate automatic braking. When warning occurs, the warning lamp lights up in the instrument cluster display .

When Front Assist is enabled, the pedestrian monitoring system, as a part of Front Assist, is activated within the vehicle speed range of approximately 5 km/h to 65 km/h.



WARNING

Pedestrian monitoring system cannot replace the driver's attention and operates only within the limits of the system. Never take risks with



the improved comfort provided by pedestrian monitoring system. Drivers are always responsible for braking in a timely manner.

- If pedestrian monitoring system issues a warning, brake your vehicle immediately depending on the traffic situation or avoid the pedestrian.
- Pedestrian monitoring system cannot independently prevent accidents and serious or fatal injuries.
- Pedestrian monitoring system may provide unnecessary warnings and interventions in complex driving conditions, such as in a main road with branches.
- Pedestrian monitoring system may provide unnecessary warnings and interventions when its functionality is compromised, such as when the radar sensor is obstructed or positioned incorrectly.
- Always be prepared to take control of the vehicle by yourself.

Operating Front Assist

 Please refer to  at the start of the chapter on page 118.

Front Assist and the advance warning are automatically switched on when you switch on the ignition.

 Depending on vehicle equipment, the indicator lamp lights up yellow or white if Front Assist is not available or only partially available. When the indicator lamp lights up white, the warning lamp may also illuminate at the same time .

Volkswagen recommends that Front Assist and also the distance and advance warnings are switched on at all times. Exceptions → page 120.

Switching on and off

- Depending on vehicle equipment, you can switch Front Assist on and off manually on the display of the instrument cluster → page 24.

 If Front Assist is switched off, the advance and distance warning will be switched off simultaneously. The indicator lamp lights up yellow or white in the instrument cluster display.

Troubleshooting

📖 Please refer to ⚠️ at the start of the chapter on page 118.

Front Assist is starting up

Depending on vehicle equipment, the indicator lamp lights up yellow or white. When the indicator lamp lights up white, the warning lamp may also illuminate at the same time ⚠️.

- Front Assist is temporarily unavailable or limited. Front Assist is available after driving straight ahead for a short time, and the indicator light goes out. When the vehicle is not in motion, the indicator lamp lights up continuously.

Front Assist is not available, the radar sensor does not have sufficient visibility.

- The radar sensor is dirty. Clean the radar sensor → page 204.
- The view of the radar sensor is impaired due to the weather conditions, e.g. snow, or due to detergent deposits or coatings. Clean the radar sensor → page 204.
- The view of the radar sensor is impaired by add-on parts, number plate holders with trim frames or stickers. Keep the area around the radar sensor free.
- The radar sensor has been displaced or damaged, for example, due to damage to the front end of the vehicle. Check whether damage is visible → page 210.
- Paint work or structural modifications were carried out on the front of the vehicle.
- The genuine Volkswagen radiator grille is not used.
- If the fault persists, go to a correspondingly qualified workshop. Volkswagen recommends using a Volkswagen dealership.

Front Assist does not work as required or is triggered repeatedly by accident.

- The radar sensor is dirty. Clean the radar sensor → page 204.
- The system limits have been exceeded → page 120.
- If the fault persists, go to a correspondingly qualified workshop. Volkswagen recommends using a Volkswagen dealership.

Parking and manoeuvring

Parking

Parking

Follow the prescribed sequence of tasks.

- Always park your vehicle in the appropriate parking space → ⚠️.
- Press and hold the brake pedal until the engine stops running.
- Switch on the electronic parking brake → page 123. If the indicator light in the button → Fig. 98 is on *the red jump lead* and the indicator lamp in the instrument cluster display Ⓜ️ lights up *the red jump lead* when the electronic parking brake is activated.
- With an automatic gearbox, engage the parking lock P.
- With a manual gearbox, clutch the pedal to the bottom. *fully* the clutch pedal.
- Stop the engine and release the brake pedal.
- To engage the steering lock, turn the steering wheel slightly if necessary.
- With a manual gearbox, select first gear for flat ground and uphill gradients, or reverse gear for downhill gradients, and then release the clutch.
- Make sure all occupants, especially children, are out of the vehicle.
- Always take all vehicle keys with you when you leave the vehicle.
- Lock the vehicle.

Information on parking the vehicle

Before switching off the ignition, to prevent the vehicle from rolling, turn the steering wheel to make the front wheels rest against the curb.

- When parking facing downhill, turn the steering wheel so that the front wheels rest against the curb.
- When parking facing uphill, turn the steering wheel so that the rear wheels rest against the curb.

WARNING

The components of the exhaust system become very hot and can lead to a fire and cause serious or fatal injuries.

- Always park the vehicle in a safe location away from flammable materials such as leaves, dry grass, or spilled fuel to prevent the hot exhaust system from igniting them and causing a fire.

⚠ WARNING

Improper exiting and parking may result in vehicle roll away. This may cause loss of control over the vehicle, accidents and serious or fatal injuries.

- Before leaving the vehicle, always switch on the electronic parking brake and ensure that the indicator lamp  in the instrument cluster display lights up red after the ignition is switched off.
- Never remove the vehicle key from the ignition lock while the vehicle is in motion. This may cause the steering lock become stuck and no longer be able to steer or control the vehicle.
- If children, people requiring assistance are left unattended in the vehicle, they could accidentally switch off the electronic parking brake, operate the gear lever or selector lever and set the vehicle in motion.
- Always take all vehicle keys with you when leaving the vehicle. Otherwise, children or unauthorised persons could start the engine or switch on the ignition and thus operate electrical equipment, such as the electric windows. This can result in accidents and serious or even fatal injuries.
- Do not leave children or individuals who need assistance alone in the vehicle. In case of an emergency, they may become trapped in the vehicle and unable to safely evacuate or seek help. For example, during seasonal changes, the interior of a closed vehicle can become extremely hot or cold, which can cause injury, illness, or even death to the occupants, particularly young children who are more vulnerable.

! NOTICE

- When driving into or out of a parking space, watch out for protruding objects that may damage the vehicle's bumper and other components. Be careful when driving in parking lots with protruding curbs or fixed blocks, and stop before the wheels touch the lane divider or curb.

- Be careful when driving over potholes, entrances and exits of driveways, slopes, curbs, and other protruding objects that may damage the bottom components of the vehicle, such as bumpers, spoilers, chassis, engine, and the exhaust system.



Observe any country-specific regulations for parking.



Electronic parking brake

Operating the electronic parking brake





Fig. 98 In the centre console: button for the electronic parking brake

Switching on

- When the vehicle is stationary, pull and hold the  button.
- The indicator lamp  Fig. 98 in the button and the red indicator lamp  in the instrument cluster light up when the electronic parking brake is switched on.
- Release the button.

Switching off

- Switch on the ignition.
- Depress the brake pedal and press the  button. Or when the engine is running, gently press the accelerator without pressing the brake pedal.
- The indicator lamp  Fig. 98 in the button and the red indicator lamp  in the instrument cluster go out.

Automatic switch-off when driving off

The electronic parking brake is released automatically when driving off if one of the following situations occurs when the driver door is closed.

- Vehicles with an automatic gearbox: A position is engaged or changed.
- Vehicles with a manual gearbox: The clutch is depressed fully before driving off.

Moving off on steep uphill gradients or with increased vehicle weight

You can prevent the electronic parking brake from switching off automatically by pulling up the  button and holding it continuously while moving off.

If higher engine power is required to pull away, the electronic parking brake will not be switched off until you release the  button.

Automatic switch-on if the driver does not leave the vehicle correctly

If the system detects that the driver has not exited the vehicle correctly, the electronic parking brake may switch itself on automatically.

Emergency braking function

The emergency braking function should be used only in those situations where the vehicle cannot be stopped using the foot brake → .

- Pull and hold the  button. The vehicle brakes strongly. An acoustic warning sounds at the same time.

WARNING

Improper use of electronic parking brake may cause accidents and serious or fatal injuries.

- Never use the electronic parking brake, except in an emergency. The electronic parking brake is not designed for braking the vehicle. The braking distance is considerably longer as only the rear wheels are braked in some cases. To brake the vehicle, always use the foot brake.
- If the engine is running and a gear is engaged, be careful not to press the accelerator unintentionally. Otherwise, the vehicle may start moving even if the electronic parking brake is switched on!

WARNING

Improper exiting may result in vehicle roll away. This may cause accidents, serious or fatal injuries, and property damage.

- Follow the prescribed sequence when parking → page 122, *Parking*.
- Before leaving the vehicle, always switch on the electronic parking brake and ensure that the indicator lamp  in the instrument cluster display lights up red after the ignition is switched off.

Troubleshooting

The electronic parking brake is activated.

The indicator lamp  lights up red.

Holding force of the electronic parking brake is insufficient

The indicator lamp  flashes red.

Unable to park safely

- Always park the vehicle on a firm and level surface.
- Pull and hold the electronic parking brake button until driving off.

Fault in electronic parking brake

The indicator lamp lights up yellow. Go to a correspondingly qualified workshop. Volkswagen recommends using a Volkswagen dealership.

Electronic parking brake does not switch itself off

The prerequisites for switching off the electronic parking brake are not met.

or: The 12-volt vehicle battery is discharged.

- Check if the preconditions for switching off the electronic parking brake are met → page 123.
- Use jumper cables for emergency starting → page 159.

Noise of electronic parking brake

- Noises may be heard when the electronic parking brake is switched on or off.
- If the electronic parking brake has not been used for a long time, occasional audible checks may be performed during parking.

Auto Hold function

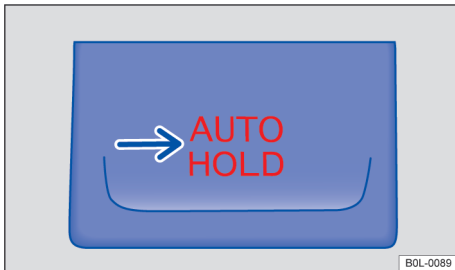

Fig. 99 In the centre console: button for the Auto Hold function

Descriptions

The Auto Hold function secures the vehicle against rolling away when stationary, without the vehicle having to be held by the foot brake.

The indicator lamp in the **AUTO HOLD** → Fig. 99 button lights up *the red jump lead* and the indicator lamp **Ⓢ** in the instrument cluster display lights up *green* when the Auto Hold function is activated.

The Auto Hold function is switched off automatically when driving off.

The hold function stops if the prerequisites for the Auto Hold function are not met when the vehicle is stationary. The *green* indicator lamp **Ⓢ** in the instrument cluster display and the **AUTO HOLD** *the red jump lead* indicator lamp in button go out.

Prerequisites

- The driver door is closed.
- The engine is switched on.

Automatic gearbox: if the selector lever is in position **N**, the Auto Hold function will **not** switch on or off automatically. As a result, the vehicle will not be held securely in a stationary position → ⚠.

Switching on

- Press the button **AUTO HOLD** → ⚠. The indicator lamp in the **AUTO HOLD** → Fig. 99 button lights up *the red jump lead*. Auto Hold is ready for use, but the vehicle is not necessarily stopped. → ⚠

The Auto Hold function remains active when the ignition is switched on again.

Keeping the vehicle stationary with the Auto Hold function

- Make sure Auto Hold is ready for use. The indicator lamp in the **AUTO HOLD** button lights up *the red jump lead*.
- Bring the vehicle to a standstill using the foot brake → page 122.
- Vehicles with a manual gearbox: keep the clutch *fully* depressed or shift to neutral.
- Release the brake pedal. The indicator lamp **Ⓢ** lights up in the instrument cluster. *green*. Keeping the vehicle stationary with the Auto Hold function → ⚠

Switching off

- Press the button **AUTO HOLD** → ⚠. The indicator lamp → Fig. 99 in the **AUTO HOLD** button goes out.

The electronic parking brake switches on automatically to hold the vehicle securely. However, the electronic parking brake **will not** switch on if the brake pedal is depressed when the Auto Hold function is switched off → ⚠.

Switching off temporarily with the **Ⓢ** button

When manoeuvring, it may be necessary to turn the Auto Hold function off once temporarily to enable the vehicle to roll more easily.

- With the engine switched on, depress the brake pedal.
- Press the **Ⓢ** button and the Auto Hold function will be switched off.

The Auto Hold function will be reactivated as soon as the brake pedal is depressed when the vehicle has come to a standstill.

⚠ WARNING

The Auto Hold function cannot replace the driver's attention and operates only within the limits of the system. Never take risks by using the additional convenience features provided by the Auto Hold function.

- Make sure that the indicator lamp **Ⓢ** in the instrument cluster display lights up green or red if the vehicle is to be held securely. When the indicator lamp lights up green, the vehicle is kept stationary with the Auto Hold function. When the red warning lamp lights up, the vehicle is kept stationary with the electronic parking brake. ▶

- Never leave the vehicle while the engine is running, even if the Auto Hold function is active.
- The Auto Hold function may not securely hold the vehicle on uphill gradients in certain conditions, such as on slippery or icy roads.

NOTICE

Switch off the Auto Hold function before driving into a car wash. The Auto Hold function may be activated automatically. This could result in damage to the vehicle.

Information about the parking systems

The parking system includes the following systems:

- Radar sensors for parking system → page 127
- Area View camera → page 129

The availability of these systems depends on the vehicle equipment.

Limits of the parking systems

Some objects may not be detected by sensors or cameras under certain circumstances, such as trailer drawbars, thin bars, fences, posts, trees, as well as open or opening boot lids.

In some cases, dirt or ice on the sensors and cameras could be registered as an obstacle.

Limits of the rear view camera system

The cameras show only two-dimensional images on the screen. The lack of depth of field means that potholes and protruding objects on the ground may only be detected with difficulty, or may not be detected at all.

Regardless of the surroundings, the system always displays guide lines and does not automatically detect obstacles. It is the driver's responsibility to assess if the parking space is suitable for the vehicle.

WARNING

The parking systems cannot replace the driver's attention and operate only within the limits of the respective system. Never take risks with the improved comfort provided by parking systems. Driver's attention is still required while parking!

- Ensure that your speed and driving style are always appropriate for the current visibility, weather and road/traffic conditions.
- Unintentional vehicle movements may cause accidents and serious or fatal injuries.
- When parking, always look in the direction of travel and observe the vehicle surroundings.
- Do not allow the displayed information on the instrument cluster or the images shown in the infotainment system distract you from holding the steering wheel.
- Pay special attention to young children and small animals when parking.
- The detection ranges of the parking systems have blind spots in which obstacles and people are not registered.
- External sources of sound and certain surfaces on objects and clothing may influence the sensors' signals. In certain circumstances, the systems will be unable to detect or properly detect people and objects.
- Certain objects, for example narrow posts or railings, may be difficult or impossible to see on the screen because of its low resolution or poor light conditions.

WARNING

Parking systems have a response time for signalling and displaying information. There may be a delay in issuing a warning when the vehicle approaches an obstacle quickly.

- Always pay due attention and do not rely exclusively on the system.
- React promptly and never wait for the parking systems to respond.

NOTICE

Observe a safety distance of around 50 cm from walls and buildings when manoeuvring in parking spaces without kerb borders.

 It is recommended to practice using the parking systems on roads with less traffic or in car parks to become familiar with the system and its safe operation.

Park Distance Control

Introduction

This chapter contains information on the following subjects:

- Switching on and off 127
- Displays 128
- Troubleshooting 128

Park Distance Control assists the driver when parking.

Working principle

Park Distance Control uses sensors in the front and rear to detect the distance of the vehicle from an obstacle (depending on equipment).

If there is an obstacle within the sensor's detection range, the system will make a warning sound. → ⓘ. The display along the side of the vehicle may vary depending on the situation.

Settings

Depending on model, Park Distance Control can be made in the Infotainment system. For example, the volume of warning sound.

⚠ WARNING

Park Distance Control cannot replace the driver's attention and operates only within the limits of the system. Failure to comply may result in serious or fatal injury and damage to the vehicle.

- Park Distance Control is not a substitute for the full concentration of the driver.

ⓘ NOTICE

Red-coloured image segment: close obstacle. Do not drive on!

Switching on and off

📖 Please refer to ⚠ and ⓘ at the start of the chapter on page 127.



Fig. 100 In the upper section of the centre console: Park Distance Control button (illustration).

Switching on

- Park Distance Control switches itself on automatically when you engage reverse gear or begin reversing the vehicle.
- or: Depending on the vehicle, the Park Distance Control will be automatically activated when the button ⓘ is pressed to switch on the Area View camera.

Switching off

- Park Distance Control switches itself off automatically when you drive forwards at a speed of more than 10 km/h to 15 km/h.
- or: Move the selector lever to position P.
- or: press the button ⓘ in the Infotainment system.
- or: switch on the electronic parking brake.

Switching on and off the acoustic warning

- Press the button ⓘ.

Displays

📖 Please refer to ⚠️ and ⓘ at the start of the chapter on page 127.

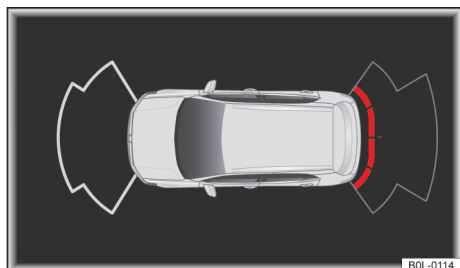

Fig. 101 Display in Infotainment system: Area detected by Park Distance Control (depending on vehicle type)

Only when the Area View camera is activated, the detection area of the Park Distance Control is displayed. → Fig. 101

When the vehicle approaches an obstacle, it is divided into multiple segments in the infotainment system to display and emit alarm sounds at the same time. → Fig. 100 The display along the side of the vehicle may differ depending on the situation.

Displays



Red-coloured image segment: close obstacle. **The vehicle is at risk. take over control of the vehicle and be prepared to brake.**



Yellow-coloured image segment: obstacle in the vehicle path. An intermittent warning sound is sounded. The closer the distance, the shorter the warning sound interval. **The vehicle is at risk. Adjust the steering wheel angle!**



White-coloured image segment: obstacle outside the path of the vehicle.

ⓘ NOTICE

Red-coloured image segment: close obstacle. **Do not drive on!**

Troubleshooting

📖 Please refer to ⚠️ and ⓘ at the start of the chapter on page 127.

Area View is not working as expected

Possible reasons:

- The sensor is dirty → page 206. Dirt, ice, detergent deposits, or coatings can impact the view of radar sensor.
- The prerequisites for system operation are not met.
- The vehicle is damaged in the area around the sensors. This may be caused by parking collisions.
- The detection range of the sensors is impaired by add-on parts, number plate holders with trim frames or stickers, e.g. bicycle carriers.
- Changes have been made to the paintwork in the area of the sensors, e.g. on the chassis.
- The ultrasound signal is subject to interference from external noise sources, e.g. uneven roads or cobblestones.

Fault information, the parking system has been switched off

The sensor area is switched off permanently if a sensor fails.

If there is a fault in the Park Distance Control, a signal tone will sound for several seconds, and the indicator lamp in the **[PWA]** button will flash when the system is initially activated.

Possible solutions

- Switch off the system temporarily.
- Check whether the above causes are involved.
- Clean the sensors or remove any labels and accessories from the sensors and cameras → page 206.
- Check for any damage.
- Switch the system on again once you have rectified the source of the fault.
- If the issue persists, go to a correspondingly qualified workshop. Volkswagen recommends using a Volkswagen dealership. ◀

Panoramic camera system (Area View)

Introduction

This chapter contains information on the following subjects:

- Prerequisites 129
- Switching on and off 129
- Troubleshooting 130

The panoramic camera system (Area View) provides a live overhead view of the vehicle's surroundings and helps detect obstacles.

The system uses multiple cameras to create images of the vehicle's surroundings and shows them on the infotainment system.

Depending on the vehicle equipment, the function and display of Area View may vary.

Features

The cameras show only two-dimensional images on the screen. The lack of depth of field means that potholes and protruding objects on the ground or the protruding parts of other vehicles may only be detected with difficulty, or may not be detected at all.

Objects or another vehicle may appear closer or farther on the screen than they actually are, such as when near an incline or when approaching objects in the front.

WARNING

Using images from the camera to estimate the distance from persons or obstacles can be inaccurate. If you do not pay due attention, there is a risk of accidents and serious injuries. Area View is not a substitute for the full concentration of the driver.

- Camera lenses can magnify and distort the field of vision. This may cause the images on the screen differ from the actual objects or not accurately reflect them.
- Do not rely exclusively on the display of Area View.

- Always be prepared to take control of the vehicle by yourself.

Prerequisites

Please refer to **▲** and **ⓘ** on page 126 and **▲** at the start of the chapter on page 129.

To use Area View, the following conditions must be met:

- Doors and boot lids are closed.
- Reliable and clear images of the vehicle's surroundings must be recognized.
- The ground is flat.
- Avoid overloading the rear or one side of the vehicle.
- Do not drive at a speed higher than around 15 km/h.

Switching on and off

Please refer to **▲** and **ⓘ** on page 126 and **▲** at the start of the chapter on page 129.

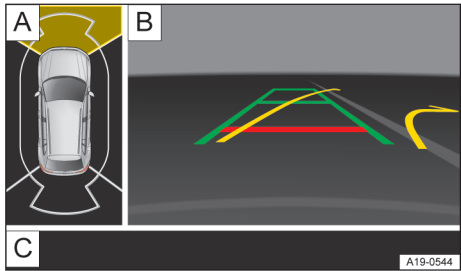



Fig. 102 Infotainment system: Rear view camera system (Area View) in the front mode.

→ Fig. 102jump leads:



- A** An aerial view of the area with optional screens.
- B** Camera view area.
- C** Function buttons of rear view camera system (Area View).

Depending on the vehicle equipment, the function and display of Area View may vary.

Open

- Select reverse gear.
- **Or:** Press the button .

Close



- Drive forwards at a speed of more than around 15 km/h.
- **Or:** Press the button  in the Infotainment system.
- **Or:** Press the button .
- **Or:** Switch on the electronic parking brake.

Screen areas









In the infotainment system, the rear view camera system is displayed in two screen areas:

- *Left screen:* Shows a bird's-eye view of the vehicle. Click on a single area, and the right screen displays the camera image of the corresponding area separately.
- *Right screen:* According to the selected area in the left screen, display the camera image of the corresponding area separately.

Camera view switching

- Click the function button area  on at the edge of the image or the display symbol in the upper left corner of the camera view area  to select the corresponding display.

Displays

	Displays the area in front of the vehicle (lateral traffic).
	Displays the area behind the vehicle (lateral traffic).
	Only the driver's side area is shown.
	Only the front passenger side area is displayed.
	Also shows the area on both sides of the vehicle.
	Top view of vehicle and surrounding environment (3D view).
	Shows the vehicle and its surroundings diagonally from inclined top (3D view).
	Setting: Activation mode and sound setting.
	Red line: boundary or vehicle safety clearance.



Yellow line: The trajectory of the vehicle based on steering angle.



Green horizontal line: boundary.

Troubleshooting

 Please refer to  and  on page 126 and  at the start of the chapter on page 129.

Without camera view, fault information, Area View has been switched off

- Clean the sensors or remove any labels and accessories from the sensors and cameras → page 206.
- Check the camera for any damage.

Area View is not working as expected

Possible reasons:

- The camera is dirty → page 206. Dirt, ice, detergent deposits, or coatings can impact the camera view.
- The prerequisites for system operation must be met → page 129.
- The sensor is covered with water.
- The vehicle is damaged in the area around the sensors. This may be caused by parking collisions.
- The detection range of the sensors is impaired by add-on parts, number plate holders with trim frames or stickers, e.g. bicycle carriers.
- Changes have been made to the paintwork in the area of the sensors, e.g. on the chassis.

Possible solutions

- Switch off the system temporarily.
- Check whether the above causes are involved.
- Switch the system on again once you have rectified the source of the fault.
- If the issue persists, go to a correspondingly qualified workshop. Volkswagen recommends using a Volkswagen dealership.

Brake support systems

Brake support systems

These braking support systems can help the driver in critical driving or braking situations. The braking support systems operate only within the limits of the respective system and may not be able to control the vehicle in every dangerous driving or braking situation. The driver is always responsible for all driving tasks → ▲.

Drive with brake support systems

The brake support systems is activated automatically when the engine is running and no special operation is required.

The brake pedal may move or noises may occur while the brake support systems are performing a control intervention. Continue to brake with the necessary force. Maintain consistent pressure on the brake pedal. If necessary, steer the vehicle after depressing the brake pedal.

Tips for brake support systems

If you suspect a system malfunction, refer to the following tips:

- The ESC, ABS and ASR can only function properly if all four wheels are fitted with the correct tyres. Variances in tyre rolling circumference can lead to unintended reduction in engine power.
- If the ABS fails, ESC, ASR and EDS will also cease to function.

The status of the brake functions is checked automatically when the ignition is switched on. The indicator lamps light up briefly and then go out again. If an indicator lamp remains lit up, there is a fault. Go to a suitably qualified workshop immediately and have the system checked. Volkswagen recommends using a Volkswagen dealership.

Electronic stability control (ESC)

ESC control intervention to reduce the risk of skidding and improve driving stability → ▲.

ESC is always in the enabled state.

Acceleration slip regulation (ASR)

ASR reduces the drive output if wheelspin occurs and adapts the output to suit the road surface conditions → page 132. The ASR makes it easier to pull away, accelerate, and drive up hills.

Anti-lock brake system (ABS)

ABS prevents the wheels from locking during braking so that the vehicle can still be steered → page 132.

Brake assist system (BAS)

BAS can help to reduce the stopping distance. The brake assist system reinforces the braking force when the driver depresses the brake pedal quickly in an emergency situation.

If the pressure on the brake pedal is reduced, the BAS will be switched off.

Electronic differential lock (EDS and XDS)

EDS brakes a spinning wheel automatically and distributes the drive force to the other drive wheels.

EDS switches itself off automatically in case of excessive load to prevent overheating of the brake. It switches back on automatically once the brake has cooled down.

XDS is an extension of the electronic differential lock and improves traction by braking interventions in order to keep the vehicle on its intended course.

Automatic anti-collision braking system

The automatic anti-collision braking system provides driver support by automatically applying brake intervention in the event of a collision, reducing the risk of skidding and subsequent collisions during the accident.

The system automatically triggers braking if the airbag control unit detects a collision in an accident situation.

As long as the essential systems remain undamaged and functional during the collision, the brake support systems will be triggered automatically.

In the event of a collision, the following actions will deactivate the automatic braking system:

- If the accelerator is depressed.
- If brake pressure applied when the brake pedal is depressed exceeds the braking interventions of the system. ▶

Brake servo

The brake servo will only function when the engine is running and reinforces the pressure applied by the driver on the brake pedal.

If the brake servo is not functioning or the vehicle is being towed, the brake pedal will have to be depressed more forcefully as the braking distance will be increased due to the lack of assistance for the brake system.

WARNING

The brake support systems cannot replace the driver's attention and operate only within the limits of the respective system. Driving at high speeds on snowy, slippery, or wet roads can result in loss of control over the vehicle and may cause accidents and serious or fatal injuries.

- Always adjust your speed and driving style according to visibility, weather, road, and traffic conditions. Never take risks with the improved safety provided by the brake support systems, e.g. ABS, BAS, EDS, ASR, and ESC.
- The brake support systems operate only within the limits of the respective system. Even with ESC and other systems, there are inherent risks on slippery and wet roads.
- Driving too fast on wet roads may cause the wheels to lose traction, resulting in "drifting". If the vehicle loses traction, avoid braking, steering, and attempting to regain control.
- Maintaining a safe distance from other vehicles and adjusting speed according to road conditions is crucial, as brake support systems cannot prevent accidents caused by following too closely or excessive speed.
- Although brake support systems can effectively assist the driver in controlling the vehicle in various situations, it is essential to consider the stability of the vehicle and the grip of the tyres on the road.
- Exercise caution when accelerating on slippery roads, such as icy or snowy surfaces. Even with brake support systems, the drive wheels may experience skidding, potentially causing the vehicle to lose steering or become difficult to control.

WARNING

Improper maintenance of other vehicle components or systems or malfunction of relevant components or systems can significantly reduce the effectiveness of ESC. These components and systems include (but are not limited to) brakes, tyres, and other systems mentioned in this manual.

- Please note that modifications or alterations to the vehicle may impact the functionality of the brake support systems.
- Modifications to the wheel suspension or the use of unauthorized wheel and tyre combinations may affect the operation of the brake support systems. This may reduce the effectiveness of the systems.
- Always use suitable tyres as the vehicle's driving stability depends on tyre grip.

WARNING

Driving without the brake servo or with restricted brake servo function can considerably increase the braking distance. This can result in accidents and serious or even fatal injury.

- Never switch the engine or ignition off while the vehicle is in motion.

Troubleshooting

Anti-lock brake system failure or fault

The indicator lamp lights up yellow.

- Go to a correspondingly qualified workshop. Volkswagen recommends using a Volkswagen dealership. The vehicle can be braked without ABS.

ESC or ASR is performing a control intervention

The indicator lamp flashes yellow.

ASR has been switched off

The indicator lamp lights up yellow.

ESC has been switched off due to system restrictions

The indicator lamp lights up yellow. There is a fault or a malfunction.



- Switch the ignition off and on.
- Drive a short distance at a speed of 15 km/h to 20 km/h.
- If the indicator lamp  remains lit, go to a suitably qualified workshop. Volkswagen recommends using a Volkswagen dealership.

Noises of the brake support systems

Noises may occur while the brake support systems are performing a control intervention.

- Continue to brake with the necessary force, and if necessary steer the vehicle.

WARNING

- If the brake warning lamp  lights up together with the ABS indicator lamp , the control function of the ABS may have failed. This can cause the rear wheels to lock when you brake. Furthermore, this may cause you to lose control of the vehicle and can result in accidents with serious or fatal injuries. In this case, drive at reduced speed to the nearest qualified workshop to have the brake system checked. Volkswagen recommends using a Volkswagen dealership.
- The ABS is not functioning correctly if the indicator lamp  does not go out or the warning lamp lights up while the vehicle is in motion. The vehicle can be stopped using the normal brakes only. Go to a correspondingly qualified workshop and have the system checked. Volkswagen recommends using a Volkswagen dealership.

Practical equipment

Stowage areas

Introduction

This chapter contains information on the following subjects:

- Stowage compartment on the front passenger side 134
- Open stowage compartment in front of the centre console 135
- The stowage compartment under the front centre armrest 135
- The driver side stowage compartment 135
- The stowage compartment in the driver door 136
- Coat and bag hook 136

The stowage areas is only suitable for storing small and lightweight items.

WARNING

Loose objects may be flung through the vehicle interior in the event of a sudden driving or braking manoeuvre. This can lead to loss of control over the vehicle and cause accidents and serious or fatal injuries.

- Never leave pets or any heavy, hard, or sharp objects in the open stowage compartment, the dash panel, the luggage compartment cover, the pockets of clothing, and bags in the vehicle interior.
- Always keep stowage compartments closed while the vehicle is in motion.
- The coat hooks in the vehicle should only be used for lightweight clothing weighing max. 2.5 kg. Never leave any heavy, hard, or sharp objects in the vehicle interior.

WARNING

Objects in the driver footwell can hinder pedal operation. This can lead to loss of control of the vehicle and increase the risk of serious or fatal injuries.

- Make sure that all pedals can be operated smoothly at all times.
- The floor mats must always be properly secured in the footwell.

- No additional floor mats or other floor coverings should be placed over the fitted floor mat.
- Make sure that no objects can enter the driver footwell while the vehicle is in motion.

⚠ WARNING

Any lighters in the vehicle could be damaged or lit without being noticed by high temperatures. This could lead to serious burns and other injuries.

- Before adjusting the seat, always make sure that there is no lighter in the way.
- Before closing stowage areas or compartments, always make sure that there is no lighter in the way.
- Never stow lighters in stowage areas or compartments or on other surfaces in the vehicle. High surface temperatures, especially in summer, may cause lighters to ignite spontaneously.

ⓘ NOTICE

- Friction with objects can potentially damage the heating wires on the rear window.
- Never leave food, medicines, or other temperature-sensitive objects in the vehicle interior. Extreme temperatures can cause them to spoil or become unusable.
- Please note that objects made of translucent materials, e.g. eyeglasses, magnifying glasses, and transparent suction pads on the windows, concentrate sunlight. This may cause damage to the vehicle.

i To maintain proper airflow and ventilation inside the vehicle, do not block the air vents located between the rear window and the rear windowsill shelf.

Stowage compartment on the front passenger side

📖 Please refer to **⚠** and **ⓘ** at the start of the chapter on page 133.

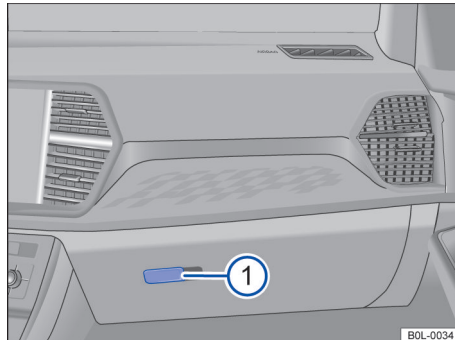

Fig. 103 On the front passenger side: stowage compartment

Open and close the stowage compartment

Open: Pull the release handle → Fig. 103**①**.

Close: Push the stowage compartment cover upwards.

⚠ WARNING

If the front passenger side stowage compartment is left open, the objects inside may fall out and cause serious or fatal injuries during accidents, emergency braking, or fast acceleration.

- Always keep stowage compartments closed while the vehicle is in motion.

ⓘ NOTICE

◀ In certain vehicle models, there may be a gap at the rear of the front passenger side stowage compartment. Small objects can fall through this gap and get lodged behind the interior panel. This may result in abnormal noise during driving and potential damage to the vehicle.

- Avoid placing small objects of this kind in the stowage compartment.

Open storage compartment in front of the centre console

📖 Please refer to ⚠️ and ⌚ at the start of the chapter on page 133.



Fig. 104 In the front of the centre console: storage compartment

i The compartment may include device for wireless charging with Qi standard, USB interface, and the 12-volt socket → Booklet *Infotainment system*.

The storage compartment under the front centre armrest

📖 Please refer to ⚠️ and ⌚ at the start of the chapter on page 133.

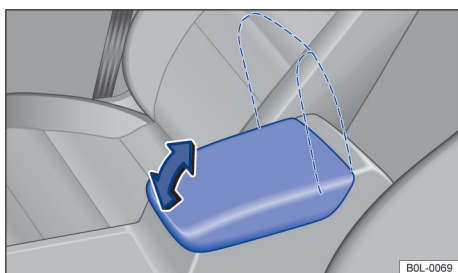

Fig. 105 Under the front centre armrest: storage compartment

Open: Lift the centre armrest → Fig. 105.

Close: Lower the centre armrest

⚠️ WARNING

The front centre armrest can restrict the freedom of movement of the driver's arms and therefore cause accidents and serious injuries.

- Always keep storage compartments closed while the vehicle is in motion.

⚠️ WARNING

Never transport an adult or child on the centre armrest.

The driver side storage compartment

📖 Please refer to ⚠️ and ⌚ at the start of the chapter on page 133.

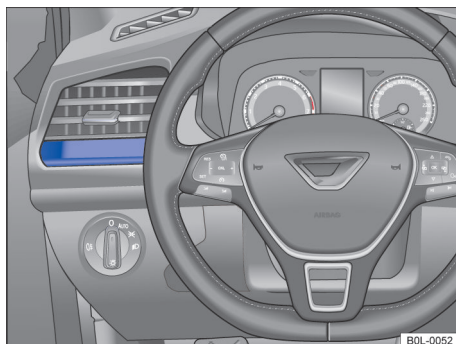

Fig. 106 The driver side storage compartment

The driver side storage compartment → ⚠️ in *Introduction* on page 133 is positioned beneath the left air conditioning vent → Fig. 106.

The stowage compartment in the driver door

📖 Please refer to ⚠️ and ⌚ at the start of the chapter on page 133.

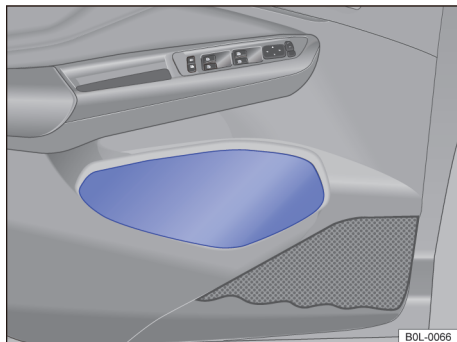

Fig. 107 The stowage compartment in the driver door

The stowage compartment in the driver door can be used to store items such as high-visibility waistcoats → Fig. 107.

⚠️ NOTICE

Avoid storing heat-sensitive items like magnetic tapes, chocolate, or medications inside the stowage compartment of the driver door. ◀

Coat and bag hook

📖 Please refer to ⚠️ and ⌚ at the start of the chapter on page 133.

Depending on the vehicle equipment, the coat hooks are located on the centre door pillar.

The bag hooks are located in the luggage compartment → page 146.

⚠️ WARNING

Hanging clothes on the coat hooks may obstruct the driver's visibility. This may cause accidents and serious or even fatal injuries.

- Always ensure that clothes hung on the coat hooks do not obstruct the driver's visibility.
- The coat hooks in the vehicle should be used only for lightweight clothing. Do not leave any heavy or sharp objects in the pockets.

⚠️ NOTICE

The coat hooks in the vehicle should only be used for lightweight clothing weighing max. 2.5 kg. ◀

Drink holders

📖 Introduction

This chapter contains information on the following subjects:

- Drink holders in the lower section of the centre console 137
- Drinks holders in the rear centre armrest 137

Drink holders

Drink holders (for bottles with a max. capacity of up to 1.5 L) are located in the driver's door and front passenger door stowage spaces.

⚠️ WARNING

Incorrect use of the drink holders can cause injury.

- Never place hot drinks in a drink holder! Hot drinks in a drink holder could be spilled and cause scalding in any sudden braking manoeuvre or accident.
- Always take care not to let drink bottles or other objects fall into the driver's side footwell and obstruct pedal movement when the vehicle is in motion.
- Do not place heavy cups, food or any other heavy objects on the cup holders, as they could travel across the carriage and seriously injure the occupants in the event of an accident.

⚠️ WARNING



Closed drink bottles can explode in the vehicle in extreme heat or burst in extremely cold temperatures and cause serious injuries.

- Never leave closed drink bottles in an extremely hot or extremely cold vehicle for extended periods. ▶

NOTICE

Do not place open drink bottles on drink holders while the vehicle is in motion! Otherwise, drinks could be spilled and damage the vehicle and the electrical equipment in any sudden braking.

Drink holders in the lower section of the centre console

Please refer to  and  at the start of the chapter on page 136.

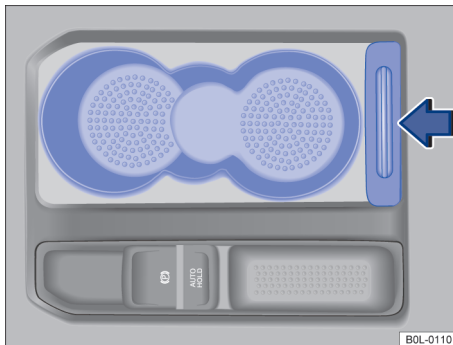



Fig. 108 In the lower section of the centre console: drink holders

Drink holder with retractable cover

Open: Push the cover on the centre console backward.

Close: Push the cover on the centre console forward → [Fig. 108](#).

Drinks holders in the rear centre armrest

Please refer to  and  at the start of the chapter on page 136.

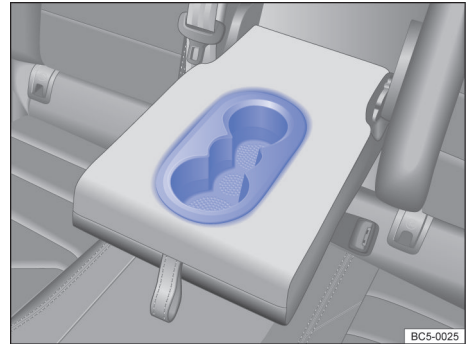

Fig. 109 On the rear armrest: drink holders

Use: To move the armrest backwards.

If the drink holder is no longer used, turn the armrest upward again.

Electrical sockets

Introduction

This chapter contains information on the following subjects:

- Sockets 138
- USB ports in the vehicle 139
- Wireless charging function 140

WARNING

Improper use of the sockets and connected electrical devices can cause fires and serious or fatal injuries.

- If children are left unattended in the vehicle, they could accidentally use the sockets and devices connected to them when the ignition is switched on.
- Switch off electrical devices immediately and disconnect them from the power supply if the electrical devices become too warm.

NOTICE

- Never connect electrical devices that supply electric power, such as solar panels or a battery charger, to the 12-volt socket to charge the 12-volt vehicle battery. This can cause damage to the vehicle and the electronic components.
- Use only electrical devices that have been approved in accordance with current guidelines concerning electromagnetic compatibility.
- Do not use faulty devices.
- In order to avoid damage due to voltage fluctuations, always switch off any electrical devices before switching the ignition on or off and before starting or stopping the engine. When the start/stop system automatically deactivates and the engine needs to be restarted, there is no need to switch off the connected electrical devices.
- Never connect electrical devices requiring more than the rated power to a 12-volt socket. The vehicle's electrical system can be damaged if the maximum power output is exceeded.
- Observe the operating instructions of the electrical devices.

 Using electrical consumers with the ignition switched on or off will drain the 12-volt battery.

 Unshielded devices can cause interference with the radio and vehicle electronics.

 If electrical devices are used near the rear window antenna, interference with the reception of AM radio signals may occur.

Sockets



 Please refer to  and  at the start of the chapter on page 137.



Fig. 110 In the upper part of the centre console: 12-volt socket (illustration).

Depending on the vehicle equipment, there may be 12-volt sockets available in the following locations:

- Upper part of the centre console.

The sockets can be used as the power supply for electrical devices with a maximum rating of 120W.

The sockets in the vehicle can be used to connect electrical devices.

The connected electrical devices must be in good working condition and free from malfunctions.

Please note that the sockets only work when the ignition is switched on.

NOTICE

The fuse can blow as a result of extended operation of the 12-volt sockets at maximum power.

- Never use the 12-volt sockets at maximum power for longer than 10 minutes.
- Always use only one 12-volt socket with maximum power.

USB ports in the vehicle

📖 Please refer to ⚠️ and ⓘ at the start of the chapter on page 137.

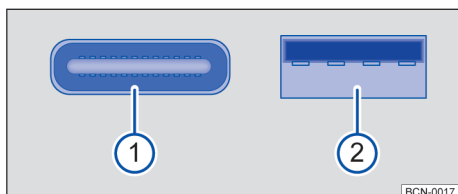

Fig. 111 USB ports (illustration)

- ① USB-C port
- ② USB-A port

Model and type of USB ports

Depending on the vehicle equipment, the vehicle may be equipped with the following USB ports:

- USB-A ⚡: Identification of a USB port suitable only for charging.
- USB-A ⚡↔: Identification of a USB port suitable for data transfer and charging.
- USB-C ⚡↔: Identification of a USB port suitable for data transfer and charging.

Depending on the vehicle equipment, the USB data transfer interface ↔ located in the front of the centre console or on the infotainment system also has power supply capability.

USB charging ports

The USB charging ports operate only when the ignition switch is switched on.

Using electrical consumers with the engine switched off and the ignition switched on will drain the 12-volt battery. Therefore, only when the engine is running can the electrical devices plugged into the power supply interface be used.

The vehicle may be equipped with USB charging ports in the following areas → Fig. 111.

Stowage compartment in the upper part of the centre console

The USB charging port provides a standard 5V charging voltage and a maximum 2A charging current. It is designed for charging mobile and tablets with data transfer capability.

This charging port can easily be identified by the symbol.

The rear of the centre console

The USB charging port provides a standard 5V charging voltage and a maximum 2A charging current. It is designed for charging mobile and tablets with data transfer capability.

This charging port can easily be identified by the battery symbol.

On the front roof or windscreen

This USB ports → ⚠️ provides power to retrofit devices such as car recorders and can supply 5 V standard voltage and up to 2 A current. → ⓘ.

⚠️ WARNING

Additional equipment such as tachographs installed in the windscreen may affect the front view and worsen driving safety!

- Make sure all windows have a clear view to prevent collisions and accidents.

ⓘ NOTICE

- Follow the operating instructions provided by the manufacturer of the electrical devices.
- **USB charging ports:**
 - Use only electrical devices that have been approved in accordance with current guidelines concerning electromagnetic compatibility.
 - Do not attempt to supply current to the charging port.

ⓘ NOTICE

The USB-port on the front roof or windscreen cannot be used to charge the phone. <

Wireless charging function

📖 Please refer to ⚠️ and ⓘ at the start of the chapter on page 137.

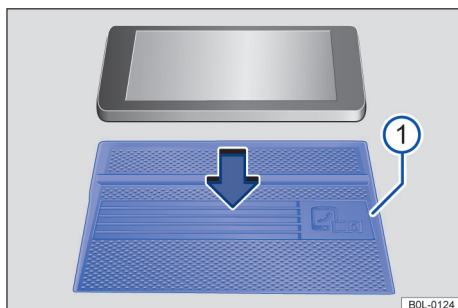

Fig. 112 Illustration: shelf with lining mat for wireless charging function.

Depending on the vehicle, the wireless charging function is located in the stowage compartment of the centre console → Fig. 112 ⓘ.

The wireless charging function enables wireless energy transmission by electromagnetic induction over a short distance.

The maximum charging capacity is 15 W.

You need a suitable Qi-certified mobile telephone in order to use the function. The lining mat → Fig. 112 ⓘ has a telephone symbol that marks the centre position of the wireless charging function.

To charge a mobile device with Qi function, place the mobile device screen up in the middle of the charging device, making sure the entire contact surface is placed in the stowage compartment. The charging process starts automatically. Consult the operating manual and manufacturer for the mobile telephone to find out if it is compatible with the Qi standard.

If the mobile telephone has not been positioned correctly in the stowage area or is too large, it cannot be detected or cannot be detected correctly. In certain circumstances, the Infotainment system will report that there is a foreign object in the stowage compartment. To do this, remove the mobile telephone and place it correctly in the stowage area for the wireless charging function.

Qi-certified mobile telephones with larger dimensions cannot be charged wirelessly.

Always place only one suitable telephone, where applicable Qi-certified, without protective case and with maximum dimensions 160 mm in accordance with the specifications on the shelf with lining mat.

⚠️ WARNING

Do not place any metal or metallic objects on the shelf for the wireless charging function. Metallic objects on the shelf can become very hot. This can cause burns or fires.

ⓘ NOTICE

Do not place any ID, bank and credit cards etc. with a magnetic stripe or chip on the shelf for the wireless charging function. This can make the data stored on the magnetic stripe or chip may be rendered unusable or damaged. ◀

Data transfer

Cyber security

Cyber security

Cyber security comprises measures to reduce the risk of unauthorised access by malware or an Internet attack on vehicle functions, data and control units.

Connectivity components

Control units for data transmission, interfaces, and media and diagnostic connections are connectivity components, via which information and data can be exchanged between the vehicle and external devices or the Internet. → ⚠. Depending on the vehicle equipment, connectivity components may include:

- Diagnostic port
- Mobile phone interface
- Media Control
- App-Connect
- Wi-Fi hotspot
- Bluetooth interface
- USB port

Connectivity components are the key elements for cyber security. Connectivity components are also equipped with security mechanisms that minimise the risk of unauthorised access to vehicle systems.

Security mechanisms

The software and security mechanisms in the vehicle are subject to ongoing development. Like with computers or the operating systems of mobile devices, the software and security mechanisms in the vehicle may also be updated at irregular intervals.

System updates improve the security, stability, and running speeds of the vehicle systems.

Minimising risks

You can reduce the risk of unauthorised access to vehicle systems and functions:

- Use only data media and mobile devices in the vehicle than do not contain manipulated data or malware.
- Have the vehicle serviced, repaired, and maintained only by a correspondingly qualified workshop. Volkswagen recommends using a Volkswagen dealership.

⚠ WARNING

Computers, data media, and mobile devices that are connected to the internet or that are used in public and private networks may be infected with viruses by manipulated data or have malware installed on them.

- Protect computers, data media, and mobile devices by means of a suitable anti-virus program and generally known precautionary measures.

⚠ WARNING

In spite of the integrated security mechanisms, malware can cause malfunctions in control units and the vehicle. Malware can affect or disable control units and the vehicle, take control actions, and lead to major accidents and fatal injuries.

- Malware can also access data and information that are stored in control units, in the Infotainment system, and on connected data media and paired mobile devices.
- Reduce speed in a controlled manner if the vehicle functions or reacts differently than usual. Go to the nearest qualified workshop. Volkswagen recommends using a Volkswagen dealership.

Cable and wireless connections

📖 Introduction

This chapter contains information on the following subjects:

- USB ports 142

Some external devices can be connected to the Infotainment system by cable and wireless connections present in the vehicle, if installed. ▶

The type and number of cable and wireless connections differ according to the vehicle equipment. The connections may also be different within a model series or in special-edition models.

In the case of cable connections, use only the original device connecting cables or, if available, the factory-supplied connecting cables for your vehicle.

If the plug on the connecting cable cannot be inserted, check the angle of insertion and the connections.

NOTICE

Use only suitable and undamaged connecting cables.

- When inserting the plugs of the connecting cables into the appropriate connection, ensure that they are correctly positioned and apply only light pressure. Applying too much pressure may damage both the unit connection and the plug of the connecting cable.
- Make sure that the connecting cable is not pinched or sharply bent.
- Incorrect usage or use of damaged connecting cables can lead to malfunctions and damage to the devices.

i If a connected device is not recognised, disconnect all devices and connect the device again. If necessary, check that the connecting cable you are using is working properly.

i If a connected device malfunctions, restart the device. In some cases, this will remedy the fault.

USB ports

📖 Please refer to **①** at the start of the chapter on page 142.

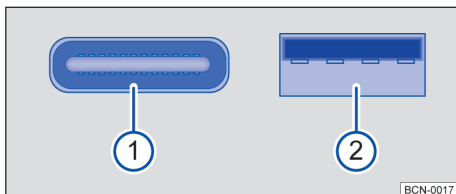



Fig. 113 USB ports (illustration)

- ① USB-C port
- ② USB-A port

Model and type of USB ports

The following USB ports may be available in the vehicle:

- USB-A : Identification of a USB port suitable for data transfer and charging.
- USB-C : Identification of a USB port suitable for data transfer and charging.

Use only suitable USB connecting cables. The USB connecting cable must match the USB port installed in the vehicle.

The USB port  provides a standard 5V voltage.

The type, number, and fitting locations of USB ports depend on the vehicle and equipment.

The infotainment system supports “Large Capacity Storage Mode” for high-capacity storage devices and audio sources. Refer to the relevant description of the audio sources to activate this mode.

You can play and control audio files from the external data media connected to the USB port through the infotainment system.

Notes and restrictions

The number of USB ports  and compatibility with mobile telephones and other media players may vary depending on the vehicle equipment.

Due to the diverse range of data media, it cannot be guaranteed that all functions described in this section will work flawlessly.

◀ Depending on the infotainment system, if you want to access data from an external hard drive with a capacity larger than 32 GB, the file system format should be FAT32.

Also, observe any specific limitations or notes regarding media sources.

i Check the type of USB port in the vehicle before connecting the audio sources.

- Use only suitable USB connecting cables.
- The connectors of USB-A and USB-C ports have different shapes.

i If USB extension cables or USB hubs are used, this can lead to faults or failure of the USB functions. ▶

App-Connect

Introduction

This chapter contains information on the following subjects:

- Applications (apps) 143

In order to avoid distracting the driver, only certified apps can be used when driving → .

Depending on the mobile telephone used, the connection can be made through the corresponding port.

App-Connect enables the user to display and operate content and functions from the mobile telephones on the Infotainment system screen.

The availability of the App-Connect technologies is country-dependent and may vary according to the mobile device.

WARNING

Using apps while the vehicle is in motion can distract you from the road. Serious accidents and fatal injuries can occur if the driver is distracted.

- Drive with your full attention and with responsibility.

WARNING



Use of unsuitable apps or incorrect use of apps can cause damage to the vehicle, accidents with serious injuries or even death.

- Use mobile telephones and apps correctly.
- Never modify an app without authorization.
- Follow the operation manual of the mobile telephones.

NOTICE

Volkswagen is not responsible for damage to the vehicle caused by poor-quality or faulty third-party apps, inadequate programming of third-party apps, insufficient network strength, data loss, misuse of mobile devices, or malware on data media, computers, tablets and mobile telephones. 

Applications (apps)

 Please refer to  and  at the start of the chapter on page 143.

Volkswagen App-Connect allows content from Volkswagen apps and third-party apps on mobile telephones to be shown on the Infotainment system screen.

There may be problems with compatibility with third-party apps.

Apps, their use, and the necessary mobile network connection may be subject to charges.

A wide range of apps may be available and they may depend on the vehicle and country. The content, scope, and providers of apps can vary. Some apps also depend on availability of services offered by third parties.

Volkswagen is unable to guarantee that the available apps can be run on all mobile telephones and all operating systems.

The apps offered by Volkswagen can also be changed, discontinued, deactivated, reactivated, and upgraded without prior notice. 

Transporting items

Stowing luggage and loads

Cargo and luggage can be stowed in the vehicle. Observe any country-specific regulations for transporting items.

Stowing luggage safely in the vehicle

- Always distribute any loads in the vehicle as evenly as possible. Do not cover any ventilation openings.
- Always stow luggage and heavy objects in the luggage compartment → .
- Place the heavy objects as far forwards as possible.
- Observe gross axle weight ratings and the gross vehicle weight rating → page 223.
- Secure luggage in the luggage compartment to the fastening rings using suitable fixing and securing straps → page 146.
- Also stow small objects safely.
- If necessary, fold back the rear seat backrest and engage it securely.
- If necessary, adjust the headlight range → page 76.
- Adjust the tyre pressure according to the vehicle load. Observe the tyre pressure sticker → page 189.
- For vehicles equipped with a tyre pressure monitoring system, set a new load status when necessary → page 183.

WARNING

Objects that are not secured or are secured incorrectly can cause serious or fatal injuries in the event of a sudden driving or braking manoeuvre or accident. This applies particularly if objects are struck when the airbag is triggered and then flung through the vehicle interior. To reduce the risk of injury, pay attention to the following:

- Always stow all objects in the vehicle securely.
- Also stow small and lightweight objects securely.

- Stow items in the vehicle interior in such a way that they can never enter the airbag deployment zones while the vehicle is in motion.
- Always keep stowage compartments closed while the vehicle is in motion.
- Do not stow objects that could cause passengers to adopt incorrect seating positions.
- Do not sit or occupy a seat that is blocked by stowed objects.
- Do not stow any hard, heavy or sharp objects loose in any of the vehicle's open stowage areas, on the surface behind the rear seat backrest or on the dash panel.
- Remove any hard, heavy or sharp objects from items of clothing and bags inside the vehicle and stow them securely in the luggage compartment.

WARNING

Transporting heavy objects changes the vehicle's handling due to the change in the centre of gravity and increases the braking distance. Heavy loads that are not properly stowed or secured can change the vehicle handling. This can lead to loss of control over the vehicle and cause serious or fatal injuries.

- Never overload the vehicle. Both the load and the distribution of the load in the vehicle will have an effect on the driving response and braking distance of the vehicle.
- Transporting heavy loads may affect the vehicle's driving performance due to centre deviation.
- Always distribute the load evenly and as low down as possible in the vehicle.
- Always stow heavy items in the luggage compartment as far as possible in front of the rear axle.
- Loose items in luggage compartment may slip suddenly and change the vehicle handling
- Always adjust your speed and driving style according to visibility, weather, road, and traffic conditions.
- Accelerate particularly carefully and gently.
- Avoid sudden braking and driving manoeuvres.
- Brake earlier than usual if the vehicle is heavily loaded.

NOTICE

Rubbing objects on the rear windows can cause damage to the heating wires or antennas (depending on configuration).

Luggage compartment cover

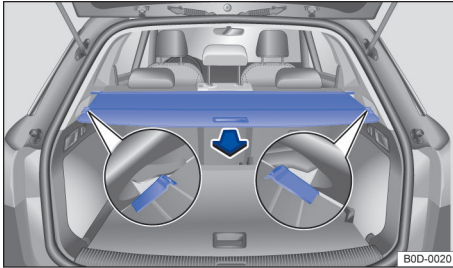

Fig. 114 In the luggage compartment: the luggage compartment cover is raised

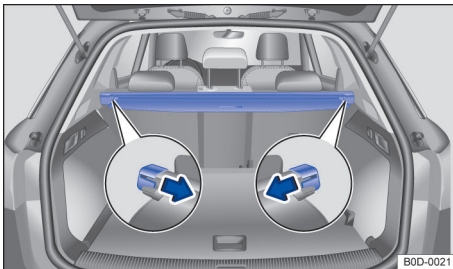

Fig. 115 In the luggage compartment: the luggage compartment cover is lowered

The luggage compartment cover can block the view from the outside of the luggage compartment to protect the privacy of the user and ensure the safety of the property.

Raising the luggage compartment cover

- Lowering the luggage compartment cover.
- Grab the handle → Fig. 114 and pull back the cover so that both sides hang into the fixed slots in the luggage trim.

Roll up the luggage compartment cover

- Raised the luggage compartment cover
- Grab the handle and slightly pull the cover so that both sides of the cover come out of the fixed slots in the luggage trim and slowly roll it up. → Fig. 114

Removing the luggage compartment cover

- Lowering the luggage compartment cover.
- Press the luggage compartment cover out of the side holders in the luggage compartment → Fig. 115.

Removed luggage compartment cover should be securely stored in the luggage compartment.

Fitting the luggage compartment cover

- Push the luggage compartment cover into the side holders in the luggage compartment. → Fig. 115
- Check whether the holders is firmly stuck.

WARNING

Never transport any objects on the luggage compartment cover.

- Never leave hard, heavy or sharp items scattered or bagged on the luggage compartment cover.
- Never transport any animals on the luggage compartment cover.
- Fix the removed luggage compartment cover.

NOTICE

The luggage compartment cover is not suitable as a shelf for objects, not even for light pieces of clothing.

Luggage compartment floor

Luggage compartment floor

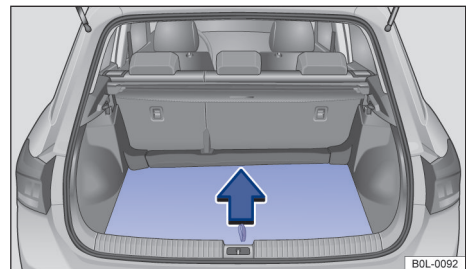

Fig. 116 In the luggage compartment: opening the luggage compartment floor.

Opening the luggage compartment floor

- Grab the ring handle → Fig. 116 on the luggage compartment floor and lift the the luggage compartment floor upwards.

Closing the luggage compartment floor

- Lower the luggage compartment floor onto the side supports → ⓘ.

ⓘ NOTICE

- Do not allow the luggage compartment floor to fall when closing it, but always guide it downwards carefully. Incorrect use can damage the luggage compartment floor or the trim of the luggage compartment. <

Luggage compartment equipment

Bag hook



Fig. 117 In the luggage compartment: bag hook

There may be bag hooks on the left and right side of the luggage compartment → Fig. 117.

Hooks can hang light shopping bags.

⚠ WARNING

Items of luggage or other objects that are fastened to the bag hooks can tear off in the event of a braking manoeuvre or accident.

ⓘ NOTICE

The bag hooks in the vehicle should only be used for lightweight object weighing max. 2.5 kg. <

Roof carrier

📖 Introduction

Due to technical reasons, this vehicle is not approved for use of a roof carrier.

⚠ WARNING

Never install a roof carrier on the vehicle that is not approved for use with a roof carrier. This can cause accidents and serious or fatal injuries.

- Do not fit a roof carrier on the vehicle roof.
- The roof carrier can become detached while the vehicle is in motion and fall off the vehicle roof.

ⓘ NOTICE

Securing a roof carrier of any kind to this vehicle can lead to severe damage. <

Fuel and emission control

Safety information on using fuel

⚠ WARNING

Incorrect handling of fuel can cause explosions, fire, serious burns and other injuries.

- Switch off the engine, ignition, your mobile phone and other radio equipment before re-fuelling.
- Avoid electrostatic discharges by not entering the vehicle during refuelling.
- Make sure that the tank cap is closed properly and no fuel can escape.
- Observe the applicable safety instructions and local regulations on handling fuel.

⚠ WARNING

Incorrect refuelling can lead to vehicle damage.

- Use only fuels that have been approved for the vehicle.
- Do not use fuels that contain metals and use only Volkswagen-approved service additives in the approved quantity.
- Immediately remove any fuel that is spilled from all vehicle components.

⚠ CAUTION

Fuel may leak out of the fuel canister and ignite. This could cause fire and injuries.

- Do not carry a fuel canister in the vehicle.

 Fuels can pollute the environment. Collect any service fluids that are spilled and dispose of them correctly.

 The tank flap cannot be opened manually. Seek expert assistance in an emergency.

Fuel types and refuelling

📖 Introduction

This chapter contains information on the following subjects:

- Identification of fuels and fuel standards 147
- Petrol 148
- Refuelling 149

The tank flap is located at the rear right-hand side of the vehicle.

For information about the warning lamp and indicator lamp, refer to Troubleshooting → page 151. ◀

Identification of fuels and fuel standards

📖 Please refer to ⚠ and ⚠ on page 147.

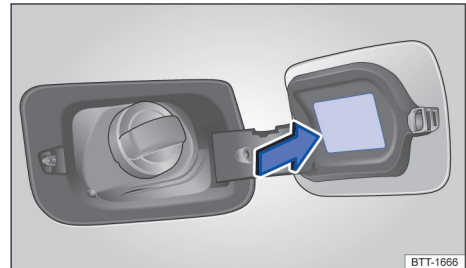

Fig. 118 On the inside of the tank flap: fuel information label

Different engines require different fuels. There is a factory-fitted fuel information sticker in the tank flap → Fig. 118 that indicates the fuel that must be used for the vehicle.

◀ **The fuel information label specifies the minimum fuel grade (e.g. minimum RON92).**

If only one fuel grade or RON is listed on the label, it represents the minimum requirement.

The vehicle may also be filled with fuel that has a higher RON than the engine requires. However, this does not provide any advantage in terms of fuel consumption or engine output. ▶

The fuel information label specifies two fuel grades (e.g. RON95 / minimum RON92)

If two fuel grades or octane numbers (RON) are listed on the label, you can choose either grade. The fuel grade listed as an alternative, RON 92 in the example above, can be used for refuelling only if the preferred grade, RON 95 in the example, is not available. The highlighted octane number, RON 95 in the example, is the preferred fuel grade for which the vehicle has been designed and optimised.

Using fuel with a lower grade or RON

Never use fuel with a lower grade or octane number (RON) than the minimum indicated on the fuel information label.

This may increase fuel consumption and reduce engine output. In extreme cases, this may cause engine damage.

Any vehicle malfunctions or damages caused by using fuel with a lower grade or octane number (RON) than the minimum indicated on the fuel information label are not covered by the warranty.

To ensure proper operation of the emission purification system, only low-sulphur or sulphur-free fuel should be used, and the use of fuel additives containing metals, such as octane boosters, is prohibited.

Petrol

- RON¹⁾ 92: 92RON premium unleaded petrol
- RON¹⁾ 95: 95RON premium unleaded petrol
- RON¹⁾ 98: 98RON premium unleaded petrol

Detailed description: → page 148

NOTICE

- Using fuel with a lower grade or octane number (RON) than the minimum indicated on the fuel information label can reduce the engine output. In extreme cases, this may cause severe damage to the engine, fuel system, or emission purification system.
- Before refuelling, ensure that the fuel standard specified on the pump meets the vehicle's requirements and has at least the minimum octane number listed on the fuel information label. Refuel only with fuels that comply with

the specified standard and identification. Failing to do so may cause damage to the engine, fuel system, or emission purification system. ◀

Petrol

📖 Please refer to ⚠ and ⚠ on page 147.

For detailed information on fuel standards, refer to the fuel standards section → page 147.

Petrol grades

Petrol is classified according to its octane rating, for example, 92, 95, or 98RON (RON = "Research Octane Number").

This vehicle is compatible with all fuel grades listed on the fuel information label. However, for optimal engine power and fuel efficiency, it is recommended to use the highest fuel grade listed on the label during full load conditions, for example high-speed driving.

The vehicle may also be filled with petrol that has a higher RON than the engine requires. However, this does not provide any advantage in terms of fuel consumption or engine output.

Never use petrol with a lower grade than the minimum indicated on the fuel information label. Volkswagen is not responsible for any vehicle malfunctions or damage caused by this.

Petrol additives

The fuel quality affects the running properties, performance, and service life of the engine. Use only high-quality petrol with harmless petrol additives provided by reputable fuel manufacturers. Never add third-party petrol additives without the approval and recommendation of Volkswagen → ⓘ.

In case you cannot find petrol with additives or encounter engine issues, you may add Volkswagen-approved additives to the petrol.

Not all petrol additives available in the market are suitable for this vehicle. Using petrol additives that are not compatible with this vehicle ▶

¹⁾ RON = Research Octane Number

may cause damage to the engine. It is recommended to use "Volkswagen-approved additives". Volkswagen dealerships have suitable additives specifically designed for this vehicle. For more information, please consult the Volkswagen dealerships.

Ethanol gasoline

Ethanol gasoline can only be used if it meets the ethanol percentage requirements set by national laws.

The type of fuel to be filled depends on the vehicle engine. There is a factory-fitted fuel information sticker in the tank flap that indicates the fuel and the maximum ethanol content (e.g. E10 = 10% ethanol) that must be used for the vehicle.

Due to the cold starting characteristics, ethanol gasoline may have slightly lower cold-start performance compared to non-ethanol gasoline, especially at very low ambient temperatures.

NOTICE

Incorrect refuelling or use of unsuitable petrol additives can lead to vehicle damage.

- Only use petrol that meets the GB17930 standard and has the correct octane number specified. Failure to do so can result in severe engine and fuel system damage, reduced engine output, or even cause the engine to stop running. Volkswagen is not responsible for any vehicle malfunctions or damage caused by this.
- Before refuelling, check whether the fuel standard specified on the pump meets the vehicle's requirements.
- Use only Volkswagen-approved service additives in the approved quantity if necessary.
- If the petrol with a lower octane number than the minimum requirement is added in an emergency, use extreme caution when driving to avoid excessive engine speed and heavy load. Otherwise, this may cause damage to the engine. Avoid high speed and heavy load engine operation. This may cause to the engine. Refill petrol with an octane number suitable for this vehicle as soon as possible.
- Do not use leaded petrol! Leaded Replacement Petrol (LRP) also contains high concentrations of metal additives that can cause damage to the engine.

- Using non-standard petrol may lead to malfunctions of the exhaust system and trigger the exhaust system warning light. If this happens, reduce your speed and drive cautiously to the nearest qualified workshop and have the engine and exhaust system checked. Volkswagen recommends using a Volkswagen dealership.
- Using even a single tank of leaded petrol can significantly impair the efficiency of the catalytic converter or even damage the catalytic converter.

Refuelling

📖 Please refer to ⚠️ and ⚠️ on page 147.

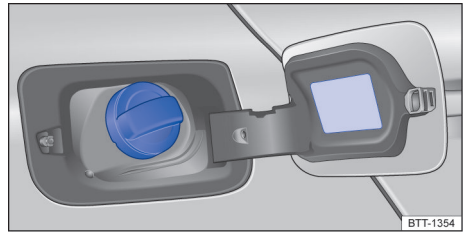

Fig. 119 Behind the tank flap: tank cap (illustration).

For information about the fuel filling capacity, refer to the technical data → page 223.

Refuelling process

- To unlock the tank flap, unlock the vehicle with the vehicle key or the button in the driver door.
- Open the tank flap.
- Unscrew the tank cap and place it in the opening provided in the tank flap.
- The fuel tank is full when the filler nozzle clicks off for the first time → ⚠️.
- Screw the tank cap onto the tank filler neck until you hear it click into place.
- Close the tank flap.

WARNING

Overfilling the fuel tank may cause the fuel to splash out and overflow. This could cause explosions, fires and serious or fatal injuries.

- Do not continue refuelling when the filler nozzle switches off for the first time.

Emission control

Introduction

This chapter contains information on the following subjects:

- Catalytic converter 150
- Particulate filter 150
- Troubleshooting 151

Depending on the vehicle equipment, the emission level achieved by the vehicle at the time of manufacture should comply with the requirements of GB18352.6 - 2016.

The components relevant to emission control reduce harmful emissions:

- Catalytic converter → page 150
- Particulate filter → page 150

For information about the lit-up warning lamp and indicator lamp, refer to Troubleshooting → page 151.

WARNING

The engine exhaust gas contains colourless and odourless poisonous carbon monoxide, which can cause unconsciousness and death.



- Do not allow the engine to run in enclosed spaces.
- Never start the engine in enclosed spaces.
- Do not leave the vehicle unattended if the engine is running.

WARNING

The components of the exhaust system become very hot and can lead to a fire and cause serious or fatal injuries.

- Park the vehicle so that no part of the exhaust system can come into contact with any inflammable material underneath the vehicle, e.g. dry grass.
- Never apply additional underseal or anti-corrosion coatings to the exhaust pipes, catalytic converters, heat shields or particulate filter.

Catalytic converter

Please refer to  and  on page 147 and  at the start of the chapter on page 150.



Observe the following information to help ensure the long-term functionality of the exhaust system and the catalytic converter in the petrol engine:

- Only use fuel that has been approved for the vehicle → page 148.
- Do not run the fuel tank empty → page 149.
- Do not overfill engine oil → page 173.
- Do not tow-start the vehicle. Use jumper cables for emergency starting → page 160.

If you notice misfiring, loss of power or uneven running when driving, reduce speed immediately and have the vehicle checked by a correspondingly qualified workshop → page 151. Otherwise, unburned fuel can enter the exhaust system and escape into the atmosphere. The catalytic converter can also be damaged by overheating.

 The emissions may have a sulphur-like smell even if the emission purification system is working properly.

Particulate filter

Please refer to  and  on page 147 and  at the start of the chapter on page 150.

Function

To comply with national regulations on vehicle emissions, certain vehicle models are equipped with particulate filters in their emission purification systems. These filters are designed to capture fine carbon particles from the exhaust gases, thereby reducing atmospheric pollution.

In order to maintain optimal particulate filter performance, engines equipped with a particulate filter should be used in conjunction with low-ash engine oil → page 170 to ensure the proper functioning of the filter.

Regeneration¹⁾

During vehicle operation, the particulate filter continuously captures carbon particles from the exhaust gas and undergoes intermittent combustion at high temperatures.

In normal vehicle operation, the soot in the particulate filter is burnt off at high temperatures on a periodic basis. If it is not possible for the filter to clean itself, for example if the vehicle is only ever used for short trips, the filter will become saturated with soot. When the accumulation reaches a certain level, the particulate filter requires regeneration.

Noises, slight smells, and increased idle speeds may occur during regeneration. **These are not indicative of any malfunction.** Additionally, it is possible to observe the radiator fan continuing to run during driving or after the engine has been switched off.

The particulate filter requires regeneration

When the yellow indicator lamp  lights up, the engine will initiate active regeneration. It is recommended to drive at medium to high speeds for a certain distance to facilitate the swift completion of the regeneration process by the particulate filter.

The regeneration process is performed automatically by the engine, and the indicator lamp  should switch off once regeneration is complete.

If the indicator lamp remains lit up or if indicator lamp **EPC** appears (some vehicle models may appear indicator lamp ), go to the nearest qualified workshop. Volkswagen recommends using a Volkswagen dealership. If not handled in time, the driving experience may be impacted. This could potentially cause damage to the particulate filter.

WARNING

Unintended driving manoeuvres may put other road users at risk.

- Always adjust your speed and driving style according to visibility, weather, road, and traffic conditions.





- Comply with the relevant national and local traffic regulations.

CAUTION

If the engine operates under the following conditions for an extended period, the particulate filter will quickly accumulate carbon particles. It is recommended to avoid working under these situations continuously. These situations include:

- Frequent short journeys
- Frequent cold starts of the engine at low temperatures.

Troubleshooting

 Please refer to  and  on page 147 and  at the start of the chapter on page 150.

Irregular engine running and faults

Irregular engine running or faults when driving may be a sign of poor fuel quality:

- Reduce your speed immediately.
- Drive to the nearest correspondingly qualified workshop at medium engine speeds and low loads on the engine. Volkswagen recommends using a Volkswagen dealership.
- If these symptoms occur immediately after refuelling, switch off the engine immediately to avoid any subsequent damage.
- Seek expert assistance.

Emissions-relevant fault

The indicator lamp lights up yellow.

Fault in an emissions-relevant component that can damage the vehicle.

- Go to a correspondingly qualified workshop and have the engine and exhaust system checked. Volkswagen recommends using a Volkswagen dealership.
- Test the engine and emissions-relevant component.

Misfiring

The indicator lamp flashes yellow.

¹⁾ Regeneration: The process of removing carbon particles from the particulate filter through technical means to restore its normal operation.

Misfiring is occurring that can damage the vehicle.

- Go to a correspondingly qualified workshop and have the engine and exhaust system checked. Volkswagen recommends using a Volkswagen dealership.
- Test the engine and emissions-relevant component.

 There may be engine faults and fuel consumption may be higher if the indicator lamps are lit up or flashing.

If and when

Vehicle toolkit

Introduction

This chapter contains information on the following subjects:

- Stowage 152
- Contents of the vehicle toolkit 153

When a vehicle breaks down, it is necessary to protect the vehicle in accordance with relevant national regulations.

Vehicle toolkit

The vehicle is equipped with a temporary spare wheel. The vehicle toolkit is located in the luggage compartment.

WARNING

In the event of a sudden driving or braking manoeuvre or accident, spare wheel or loose vehicle toolkit could be flung through the vehicle interior. This can result in serious or fatal injuries.



- Always ensure that the vehicle toolkit and spare wheel are always properly secured in the luggage compartment.

WARNING

Working with unsuitable tools or damaged tools from the vehicle toolkit can lead to accidents. This can result in serious or fatal injuries.

- Never work with unsuitable or damaged tools from the vehicle toolkit.

Stowage

 Please refer to  at the start of the chapter on page 152.

The vehicle toolkit, spare wheel, or temporary spare wheel may be located in various places in the vehicle, such as under the luggage compartment floor → page 145.

 After using the jack, crank it back to its original position so that it can be stowed safely.

Contents of the vehicle toolkit

📖 Please refer to ⚠ at the start of the chapter on page 152.

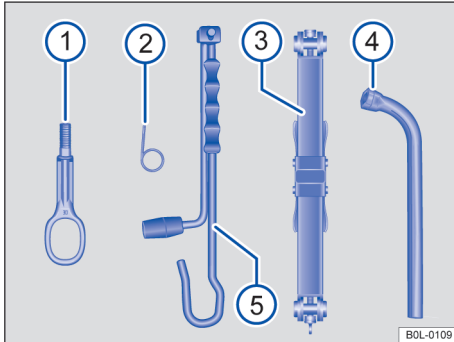

Fig. 120 Contents of the vehicle toolkit

The scope of the on-board toolkit depends on the vehicle equipment. The following describes the maximum content.

The on-board toolkit available in this vehicle is shown as below. → Fig. 120

- ① Screw-in towing eye (depending on the vehicle equipment).
- ② Hook for pulling off the centre covers, wheel covers, and the wheel bolt caps ¹⁾.
- ③ Jack. Before you repack the jack, you must fully wind in the claw.
- ④ Box spanner for wheel bolts.
- ⑤ Jack handle.

Servicing the jack

The jack is not generally subject to any maintenance intervals. Grease the jack with a universal lubricant when necessary.

¹⁾ Purchase it separately

Wipers

Moving the windscreen wipers to service position

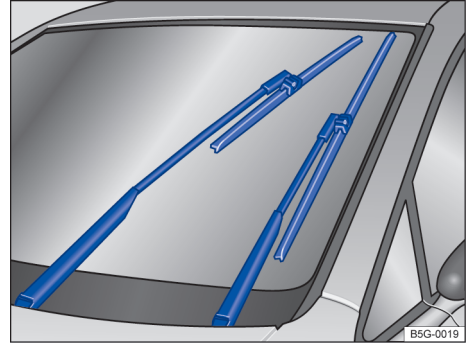

Fig. 121 Wipers in service position

The wiper arms can be lifted off the windscreen when in the service position. To place the wipers in the service position → Fig. 121, follow the actions below:

Activating the service position

- Close the bonnet → page 165.
- Switch the ignition on and then off again.
- Press the wiper lever briefly.

Lifting the windscreen wiper arms

- Move the wiper arms to the service position before lifting → ①.
- Hold and lift the wiper arm **only** in the area of the wiper blade mounting.

Before starting your journey, place the wiper arms on the windscreen. Press the wiper lever briefly with the ignition switched on. The wiper arms move back to their initial position.

⚠ NOTICE

- Only when the wiper is in the maintenance position can the wiper arm be lifted away from the windscreen to avoid damaging the bonnet and wiper arms.
- Always place the wiper arms carefully back on the windscreen before starting a journey.

Cleaning and changing wiper blades

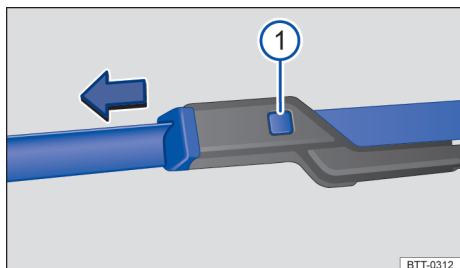

Fig. 122 Changing the windscreen wiper blades

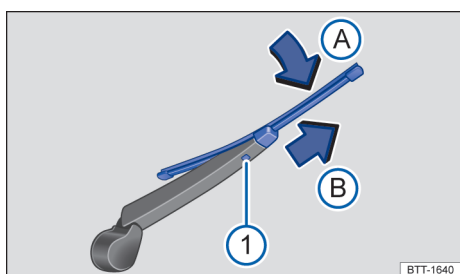

Fig. 123 Changing the wiper blade for the rear window

The factory-fitted windscreen wiper blades are coated with graphite. The graphite coating ensures that the wiper blade moves quietly over the window. If the graphite coating is damaged, the wiper will become louder.

Check the condition of the wiper blades on a regular basis. Wiper blades **that judder** should be changed if damaged or cleaned if dirty → ①.

Damaged wiper blades should be replaced immediately. Wiper blades are available from a correspondingly qualified workshop. Volkswagen recommends using a Volkswagen dealership.

Cleaning wiper blades

Windscreen wipers cleaning instructions: Move the wiper arms to the service position before lifting → page 153.

- Hold and lift the wiper arms **only** in the area of the wiper blade mounting.
- Clean the wiper blades carefully using a damp sponge → ①.
- Place the wiper arms carefully back onto the windscreen.

Changing the windscreen wiper blades

- Move the wiper arms to the service position before lifting → page 153.
- Hold and lift the wiper arms **only** in the area of the wiper blade mounting.
- Press and hold the release button → Fig. 122 ① and simultaneously pull off the wiper blade in the direction of the arrow.
- Connect a **new wiper blade of the same length and design** on the respective wiper arm and push it on until it engages.
- Place the wiper arms carefully back onto the windscreen.

Changing the wiper blade for the rear window

- Hold and lift the wiper arms **only** in the area of the wiper blade mounting.
- Lift and fold back the wiper arm.
- Press and hold the release button → Fig. 123 ①.
- Tilt the wiper blade in the direction of the wiper arm → Fig. 123 (the arrow (A)) and pull it off in the direction of the arrow (B) at the same time. You may need to use some force to do this.
- Connect a **new wiper blade of the same length and design** onto the wiper arm against the direction of the arrow → Fig. 123 (B). Push it on until it engages. The wiper blade must be in folded-down position to do this → Fig. 123 (arrow (A)).
- Place the wiper arms carefully back onto the rear window.

⚠ WARNING

Worn or dirty windscreen wiper blades reduce visibility and increase the risk of accidents and severe injuries.

- Always change wiper blades if they are damaged or worn and no longer clean the windscreen properly.

ⓘ NOTICE

- Damaged or dirty wipers can scratch the windows.
- Cleaning agents containing solvents, hard sponges, and other sharp objects may damage the graphite coating of the wiper blade.
- Do not use fuel, nail varnish remover, paint thinner or similar liquids to clean the windows. ▶

 If wax residue from car washes and other care products remains on the vehicle windows, this can cause the wipers to rub. Remove wax residue using a special cleaning product or cleaning cloths.

Changing bulbs

Introduction

This chapter contains information on the following subjects:

– “Information on changing bulbs” Checklist 156

Expertise is required to check and replace bulbs or LED light units. If you are uncertain about how to change a bulb or LED light unit, have the work carried out by a suitably qualified workshop. If the replacement requires the removal of other vehicle components, you should have them replaced by a suitably qualified workshop. Volkswagen recommends using a Volkswagen dealership.

It may be illegal to drive with faulty exterior lights.

LED light units in the vehicle

Exterior lighting may use LED technology. Some LEDs cannot be replaced. If individual LEDs fail, this may be an indication that more LEDs are on the point of failure. In this case, have the LED light units checked and renewed if necessary at a correspondingly qualified workshop.

Additional bulb specifications

Some bulbs in the headlights or combination taillights might have factory specifications that differ from standard bulbs. The designation is inscribed on the bulb, either on the glass part or on the base.

WARNING

If the road lighting is not bright enough, other road users may have difficulty seeing the vehicle or may not see it at all. This can cause accidents and serious or fatal injuries.

WARNING

Improper replacement of bulbs can cause accidents and serious or fatal injuries.

- When working in the engine compartment, always follow the described work steps and observe the general safety precautions → page 165. The vehicle's engine compartment is a high-risk area. Use extreme caution when working in the engine compartment to avoid serious injuries.
- H7 bulb is treated with high voltage inside. It may explode when replaced!
- Change bulbs only when they have cooled down completely.
- Never change a bulb unless you know exactly how to carry this out. If you are uncertain about how to change a bulb, have the work carried out by a suitably qualified workshop. Volkswagen recommends using a Volkswagen dealership.
- Do not touch the bulb with unprotected fingers. When switched on, the heat of the bulb would cause the remaining fingerprint to evaporate and be deposited on the glass. This will cause the reflector to become “blown”.
- Be cautious when replacing bulbs to avoid being scratched by the sharp parts of the headlight and combination taillight housings in the engine compartment.

NOTICE

Always fit the covers on the headlight housing after changing bulbs and make sure that the covers are secured correctly. If water enters the headlight housing, it can cause damage to the electrical system.

"Information on changing bulbs" Checklist

📖 Please refer to ⚠️ and ⓘ at the start of the chapter on page 155.

Checklist

Always carry out the following actions → ⚠️ for changing a bulb in the given order:

1. Park the vehicle on a firm and level surface at a safe distance from the flow of traffic.
2. Switch on the electronic parking brake → page 123.
3. Switch off the light. → page 73
4. Move the turn signal and main beam lever to neutral position → page 72.
5. Vehicles with an automatic gearbox: Engage the parking lock P → page 104.
6. Stop the engine and switch off the ignition → page 99.
7. Vehicles with a manual gearbox: Select a gear → page 103.
8. Allow the orientation lighting to go out → page 76.
9. Leave the defective bulbs to cool down.
10. Check to see if a fuse has visibly blown → page 156.
11. Follow the instructions to change the affected bulb → ⓘ. Always replace bulbs with identical bulbs of the same type. The designation is inscribed on the bulb, either on the glass part or on the base.
12. Do not touch the glass part of the bulb with unprotected fingers. When switched on, the heat of the bulb would cause the remaining fingerprint to evaporate and be deposited on the reflector. This will impair the light output of the headlight.
13. After changing a bulb, check to ensure that the bulb is working properly. If the bulb is not working properly, the bulb may not have been inserted properly, may have failed again, or the connector may have been fitted incorrectly.
14. Each time you change a bulb at the front of the vehicle, the headlight settings should be checked by a correspondingly qualified workshop. Volkswagen recommends using a Volkswagen dealership.

⚠️ WARNING

If the described activities for changing bulbs are not observed, this can lead to accidents and serious or fatal injuries.

- Always follow the described work steps and observe the general safety precautions.

ⓘ NOTICE

Carefully remove and refit bulbs to avoid damaging the vehicle's paint and bodywork. ◀

Changing fuses

📖 Introduction

This chapter contains information on the following subjects:

- | | |
|-----------------------------------|-----|
| – Fuses in the dash panel | 157 |
| – Fuses in the engine compartment | 157 |
| – Changing blown fuses | 158 |

Because the vehicle is constantly evolving, and the configuration of the fuse depends on the configuration of the vehicle, in addition, several appliances may share a fuse. You can get more information about the fuse layout from a correspondingly qualified workshop. Volkswagen recommends using a Volkswagen dealership.

Several electrical consumers can share a single fuse. Conversely, a single consumer could have more than one fuse.

Therefore fuses should only be replaced when the cause of the fault has been rectified. If a new fuse blows again shortly after fitting, have the electrical system checked by a correspondingly qualified workshop as soon as possible. Volkswagen recommends using a Volkswagen dealership.

⚠️ WARNING

The high voltage in the electrical system can cause electric shocks and serious burns. Contact with the electrical wiring of the ignition system can cause serious or fatal injuries!

- Never touch the electrical wiring of the ignition system.
- Avoid short circuit in the electrical system. ▶

⚠ WARNING

Using unsuitable fuses, repairing fuses and bridging an electrical circuit without fuses can cause serious damage or a fire in the vehicle. This can result in serious or fatal injuries.

- Never use a fuse with a fuse that has a higher rating. Replace fuses only with fuses with the same rating and size. Make sure that the colour and markings are identical to the defective fuse.
- Never repair fuses.
- Never use a metal strip, paper clip or similar objects to replace a fuse.

ⓘ NOTICE

- Switch off the engine and switch off the lights and other electrical consumers. Make sure that the engine cannot be started when changing a fuse.
- Damage can also be caused at other locations in the electrical system if a fuse is replaced with a fuse that has a higher rating.
- Protect open fuse boxes against the ingress of dirt and moisture because dirt and moisture in the fuse boxes can damage the electrical system.
- The fuse box cover should be carefully removed and properly installed to avoid damage to the vehicle.

i There are other fuses in the vehicle in addition to those described in this chapter. These should be changed only by a correspondingly qualified workshop. Volkswagen recommends using a Volkswagen dealership.

Fuses in the dash panel

📖 Please refer to **⚠** and **ⓘ** at the start of the chapter on page 156.

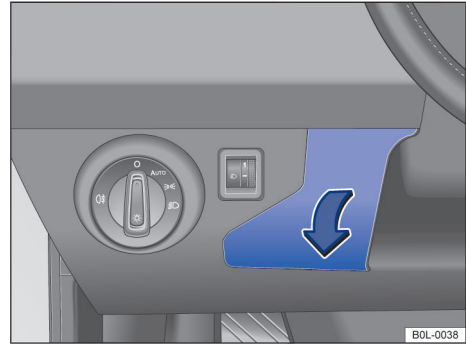

Fig. 124 In the dash panel on the driver side: fuse box cover

Opening the fuse box in the dash panel

- Grab the cover → **Fig. 124** and pull out in the direction of the arrow. **◀**

Fuses in the engine compartment

📖 Please refer to **⚠** and **ⓘ** at the start of the chapter on page 156.

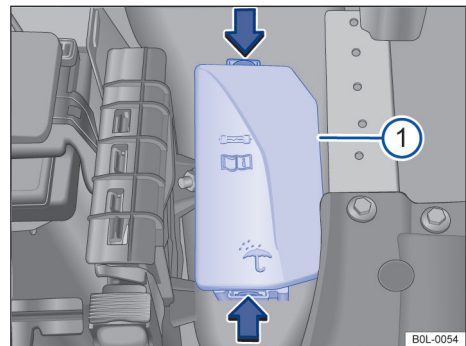

Fig. 125 In the engine compartment: fuse box cover **①**.

Opening the fuse box in the engine compartment

- Open the bonnet **△** → page 165.
- Press the button in the direction of the arrow to open the cover → **Fig. 125** **①** of the fuse box. **▶**

- Lift off the cover.
- Place the cover on the fuse box, and press the cover down until the cover audibly engages into position on both sides.

Changing blown fuses

📖 Please refer to ⚠ and ⌚ at the start of the chapter on page 156.

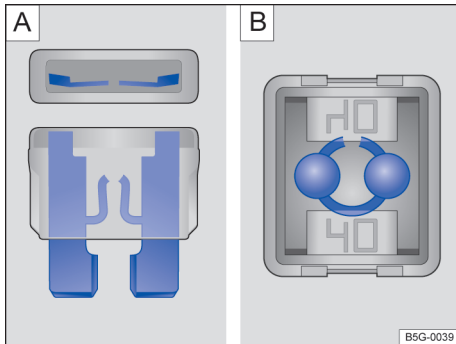

Fig. 126 Blown fuse: **A** a flat blade fuse, **B** a cartridge fuse

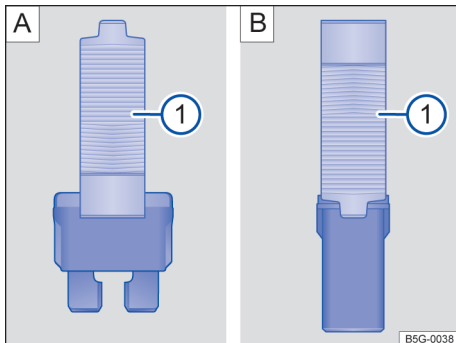

Fig. 127 Plastic grippers for pulling out and inserting a fuse: **A** a flat blade fuse, **B** a cartridge fuse

Fuse types

- Standard flat blade fuse (ATO[®])
- Small flat blade fuse (MINI[®])
- Cartridge fuse (JCASE[®])
- Large Plug-in fuse (MAXI[®] or MAXI+[®])

Colour coding of fuses

Fuse (ATO/MINI/MAXI[®] or MAXI+[®])

Colour Amp rating

- Black 1 A
- Purple 3 A
- Orange 5 A
- Brown 7.5 A
- Red 10 A
- Blue 15 A
- Yellow 20 A
- White or clear 25 A
- Green 30 A
- Light green 40 A

Fuse (JCASE)

- Blue 20 A
- Pink 30 A
- green 40 A
- Red 50 A
- Yellow 60 A

Preparation

- Switch off the ignition, the lights and all electrical consumers.
- Open the corresponding fuse box. → page 157

Detecting a blown fuse

- The blown fuse can be found by using a flash light.
- Flat blade fuse (ATO[®], MINI[®], MAXI[®] / MAXI+[®]) can be identified by looking at the fused state of the metal on the top and side of the transparent housing in which it is encased. → Fig. 126**A**
- Cartridge fuse (JCASE[®]) can be viewed through the top of the transparent housing to see if it is blown. → Fig. 126**B**

Changing fuses

- Opening the fuse box cover in the engine compartment. → page 157 Prepare a plastic gripper or similar tool¹⁾.
- Adjust the plastic gripper to the position that fit → Fig. 127 **A**(1) or → Fig. 127 **B**(1) depending on the fuse type, and clamp the fuse from the side.
- Pulling out the fuse. ▶

¹⁾ To be purchased by user.

- The blown fuse must be changed with a new fuse with the same rating (same colour and same markings) and *same* size → ⓘ.
- Insert the cover again or close the fuse box cover.

ⓘ NOTICE

Damage can also be caused at other locations in the electrical system if a fuse is replaced with a fuse that has a higher rating.

Jump starting

📖 Introduction

This chapter contains information on the following subjects:

- Jump starting procedure 160

For technical reasons, your vehicle may not be push-started → ⓘ.

If the engine cannot be started because the 12-volt vehicle battery is flat, the discharged battery can be connected to the 12-volt battery of another vehicle to start the engine.

A suitable cable is required for jump starting.

Cross section of cable for jump starting:

- at least 25 mm² for vehicles equipped with gasoline engines.

⚠ WARNING

Using the jump leads incorrectly or performing the jump start procedure incorrectly can cause the vehicle battery to explode. This can result in serious injuries! To prevent battery explosion, observe the following rules:

- Always be fully aware of the hazards when working with 12-volt vehicle batteries and electrical systems. Improper operation can easily cause fire, chemical burns, and electric shock. Always read and observe the warnings and safety information before carrying out any kind of work on the 12-volt vehicle battery. → page 179

- The voltage of the 12-volt battery must be the same as the voltage of the unpowered 12-volt battery and the capacity of both batteries must be approximately the same (see specifications on the battery).
- Never perform jump starting on a vehicle with a frozen or thawed 12-volt vehicle battery. A discharged 12-volt vehicle battery can already freeze at temperatures around 0°C.
- Always replace a 12-volt vehicle battery which is frozen or has been frozen.
- A highly explosive mixture of gases is given off when the battery is charging! Always keep fire, sparks, naked flames and lit cigarettes away from the 12-volt vehicle battery. Do not use mobile phones when connecting or disconnecting jump starting.
- Position the leads in such a way that they cannot come into contact with any moving parts in the engine compartment
- Never confuse the positive battery terminal with the negative battery terminal.
- Observe the jump lead manufacturer's instructions.

ⓘ NOTICE

In order to avoid serious damage to the vehicle electrical system, please observe the following items during operation:

- An incorrect cable connection may cause a system short circuit.
- Use only jumper start cables with safety insulated electrode clips.
- The two vehicles must not contact each other, otherwise, once connected to the positive terminal, the current will flow immediately.

ⓘ NOTICE

Tow-starting the vehicle can cause considerable damage to the vehicle.

Jump starting procedure

📖 Please refer to ⚠️ and ⌚ at the start of the chapter on page 159.

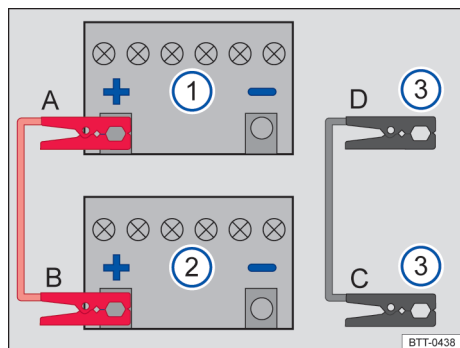

Fig. 128 Schematic diagram of how to connect the

Fig. 128 jump leads:

- ① Vehicle with depleted 12-volt battery that accept jump starting.
- ② Vehicle with a powered 12-volt battery for jump starting.
- ③ Suitable earth connection: e.g. bolted metal parts on the engine block or on the engine block itself.

The depleted battery must be properly connected to the vehicle grid.

Make sure that there is a sufficient distance between the vehicle providing jump starting assistance and the vehicle being jump started otherwise current could already flow when the positive terminals are connected.

Ensure that the terminal clamps have good metal-to-metal contact with the terminals.

If the engine does not start immediately, switch off the starter after about 10 seconds and try again after about half a minute.

Please contact an expert if the vehicle's engine still will not start.

Connect the jump leads

Only in the order A - B - C - D to connect the jumper lead. → Fig. 128

Do not connect *black* jump lead to the negative terminal of the 12-volt battery (-). Connecting the negative terminal may lead to an incorrect assessment of the battery status within the vehicle's electronic system.

- Switch off the ignition in both vehicles.
→ page 99
- If necessary, fold open the cover on the positive battery terminal (+) on the 12-volt vehicle battery in the engine compartment.
→ page 179
- Connect *the red jump lead* to the positive terminal of the 12-volt vehicle battery
→ Fig. 128 ① with the discharged vehicle battery (+) → ⚠️.
- Connect *the red jump lead* to the positive terminal of the 12-volt vehicle battery → Fig. 128 ② providing assistance (+).
- Connect *black jump lead* → Fig. 128 ③ to a solid metal part that is securely bolted onto the cylinder block or to the cylinder block itself on the vehicle with the 12-volt vehicle battery providing assistance.
- Connect the other end of the *black jump lead* → Fig. 128 ③ to a solid metal part that is securely bolted onto the cylinder block or to the cylinder block itself on the vehicle with the 12-volt vehicle battery. → ⚠️.
- Position the leads in such a way that they cannot come into contact with any moving parts in the engine compartment.

Starting the engine

- Start the engine of the vehicle which is providing assistance and let it run at idle;
- Wait a few minutes and then start the engine in the vehicle with the discharged 12-volt vehicle battery until the engine is "running smoothly".

Removing the jump leads

- Before disconnecting the jump leads, switch off the dipped beam headlights, if switched on.
- Switch on the air conditioning blower and rear window heater in the vehicle with the discharged 12-volt vehicle battery. This helps minimise the voltage peaks generated when the leads are disconnected. ▶

- After jump starting, the jump leads should be removed only in the order **D -- C -- B -- A** → Fig. 128.
- Check the 12-volt vehicle battery by a correspondingly qualified workshop. Volkswagen recommends using a Volkswagen dealership.

WARNING

Jump starting the vehicle incorrectly can cause the 12-volt vehicle battery to explode, which can lead to serious injuries! To prevent battery explosion, observe the following rules:

- Always be fully aware of the hazards when working with 12-volt vehicle batteries and electrical systems. Improper operation can easily cause fire, chemical burns, and electric shock. Always read and observe the warnings and safety information before carrying out any kind of work on the 12-volt vehicle battery. → page 179
- Always wear suitable eye protection and protective gloves. Never bend over the 12-volt vehicle battery.
- Always first connect the positive lead and then the negative lead.
- Never connect the negative lead to parts of the fuel system or to the brake lines.
- Make sure that there is no contact between the uninsulated parts of the terminal clamps. In addition, do not allow the lead attached to the positive battery terminal on the 12-volt vehicle battery to touch electrically conductive parts of the vehicle.
- Check the battery observation hole of the 12-volt vehicle battery and use a flashlight if necessary. If the window is light yellow or colourless, do not jump start the vehicle. Seek expert assistance.
- There shall be no electrostatic discharge near the 12-volt vehicle battery! The explosive gas emitted from the 12-volt vehicle battery could be ignited by sparks.
- If the 12-volt vehicle-mounted battery is damaged, frozen or thawed, the jumper cable must not be used to start the engine.

NOTICE

After jump starting, have the 12-volt vehicle battery checked by a correspondingly qualified workshop. Volkswagen recommends using a Volkswagen dealership.

Towing

Introduction

This chapter contains information on the following subjects:

- Notice on towing 162
- Towing instruction 163
- Fitting the rear towing eye 163
- Fitting the towing eye at front 164

Towing requires experience, especially when using a tow-rope. Both drivers should be familiar with the technique required for towing. Inexperienced drivers should not attempt to tow.

Make sure that no excessive pulling forces occur and take care to avoid jerking movements. When towing offroad, there is always a risk of overloading the anchorage points.

Observe any legal requirements when towing.

Towing start

To move a vehicle and start an engine with the help of towing.

The vehicle can be started with a tow-bar or a tow-rope.

Towing

Towing is where a vehicle that cannot be driven is pulled with the aid of another vehicle.

The vehicle can be towed with a tow-bar or a tow-rope. When the engine stops running, the gearbox cannot be fully lubricated as the speed increases and the distance increases:

- The maximum permitted towing speed is 30 km/h.
- The maximum permitted distance is 50 km.

Tow-rope, tow-bar

It is easier and safer to tow a vehicle with a tow-bar. Use a tow-rope only if you do not have a tow-bar.

The tow-rope must have a certain degree of elasticity, it is advisable to use a tow-rope made of synthetic fibre or similarly elastic material.

The tow-rope or tow-bar must be connected to the tow-ring provided with the vehicle. ▶

Towing with a breakdown truck

If one of your vehicle's axles is to be raised for towing, then which axle depends on the gearbox and drive combination. Only the following axles must be used:

Front-wheel drive

Manual gearbox Front axle or rear axle

Automatic gearbox Front axle

WARNING

If a vehicle is being towed, the vehicle handling and braking efficiency will change significantly.

WARNING

Do not tow a vehicle without battery power.

- Never switch off the ignition or remove the vehicle key from the ignition lock during towing, using the starter button. Otherwise the mechanical steering lock device (steering lock) or electronic steering lock device may suddenly jam. The steering wheel then can no longer be moved. This can result in accidents and serious or even fatal injuries.
- If the power supply of the vehicle fails during towing, stop towing immediately and seek expert assistance.

WARNING

Vehicle components can be severely damaged by incorrectly secured tow-ropes or tow-bars. The risk of accident is increased and serious or fatal injuries may be caused.

- Attach the vehicle only at the points provided for recovery and towing.
- Never attach the tow-rope or tow-bar to axle or running gear components.
- Seek expert assistance and have the vehicle transported standing on a breakdown truck if necessary.

NOTICE

Towing the vehicle with tow-rope or tow-bar may cause considerable damage to the vehicle.

- Carefully pull the vehicle with a tow-rope or tow-bar.
- Seek expert assistance and have the vehicle transported on a breakdown truck if necessary.



NOTICE

When pushing the vehicle by hand, do not press on the tail light clusters, side spoilers on the rear window, large panels and the rear spoiler. Otherwise it will damage the vehicle and cause the rear spoiler to come loose.

NOTICE

Remove and install cover plates and the towing eye carefully to avoid damaging the vehicle (e.g. paint).

Notice on towing

 Please refer to  and  at the start of the chapter on page 162.

It is still possible to activate the turn signals in a vehicle that is being towed, even if the hazard warning lights are switched on. To do this, operate the turn signal and main beam lever in the required direction while the ignition is switched on. The hazard warning lights will not flash while the turn signal is being used. The hazard warning lights will start flashing again automatically as soon as the turn signal and main beam lever is moved back to the neutral position.

Towing the vehicle with a manual gearbox

Check that the vehicle can be towed [page 163](#), *In which situations may the vehicle not be towed?*

- Switch on the ignition.
- Move the selector lever to neutral.
- The speed to be towed must not exceed 30 km/h.
- The distance to be towed must not exceed 50km.

Towing the vehicle with automatic gearbox:

Check that the vehicle can be towed [page 163](#), *In which situations may the vehicle not be towed?*

- Switch on the ignition.
- Move the selector lever to the position **N**.
- The speed to be towed must not exceed 30 km/h.

- The distance to be towed must not exceed 50km.
- If the vehicle is towed by a rescue vehicle, the front wheel of the vehicle must be lifted off the ground.

In which situations may the vehicle not be towed?

Do not have the vehicle towed in the following situations:

- The vehicle gearbox is damaged or without lubrication.
- The 12-volt vehicle battery is discharged. On vehicles equipped with Keyless access, the steering system will be locked and the electronic steering lock cannot be detached.
- The distance to be towed is further than 50 km.
- If the steering function or the operating clearance of the wheels cannot be ensured after an accident.

If the vehicle cannot be towed on its own wheels due to one of the above conditions, seek expert assistance and have the vehicle transported on a breakdown truck if necessary.

Towing instruction

📖 Please refer to ⚠️ and ⌚ at the start of the chapter on page 162.

Preparations

- The tow-rope or tow-bar can only be fixed to the specified tow-eye. → page 163
- Ensure that the tow-rope is not twisted. Otherwise a towing eye can become unscrewed during towing.
- Switch on the ignition and hazard warning lights on both vehicles. Observe any regulations to the contrary.
- Comply with the information on towing contained in the owner's manual for the other vehicle.

Pulling vehicle (front)

- The tow-rope must be taut before you drive off properly.
- Press the accelerator carefully. Avoid sudden braking and driving manoeuvres.
- Brake in advance and gently press the brake pedal

In vehicles with a manual gearbox:

- engage the clutch particularly gently when moving off.

Pulling vehicle (rear)

- Make sure that the ignition is always switched on so that the steering wheel is not locked and you can operate the turn signals, horn, and wipers if necessary.
- Because steering assistance may not work, the driver must turn the steering wheel with much more force than normal.
- The brake servo and power steering function only when the engine is running. Otherwise you must press the brake pedal with significantly more force and also use more effort for steering. Be careful not to get too close to the pulling vehicle.
- Switch off the electronic parking brake.
- Ensure that the tow-rope is taut.
- Put the gearbox in neutral.

Fitting the rear towing eye

📖 Please refer to ⚠️ and ⌚ at the start of the chapter on page 162.

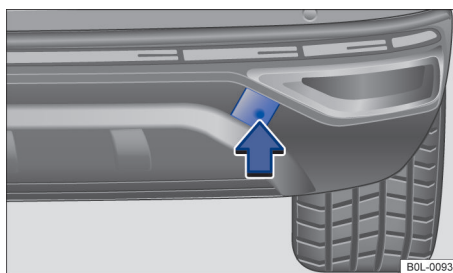

Fig. 129 In the rear bumper on the right: removing the cover

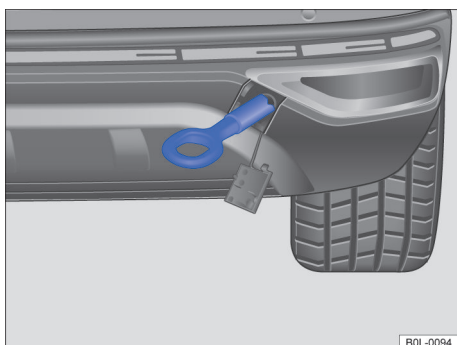

Fig. 130 In the rear bumper on the right: screwing in the towing eye

The towing eye must always be kept in the vehicle.

Pay attention to the tips about towing. → page 162

Fitting the rear towing eye

- Always use the towing eye supplied in the vehicle toolkit. → page 152
- Press the marked area of the cover in the direction of the arrow → Fig. 129 to release the cover catch.
- Remove the cover, allow it to hang on the vehicle.
- Turn the towing eye **as shown by the arrow in to the threaded hole** and tighten as far as possible → Fig. 130 → **D**. Use a suitable object to screw the towing eye fully and securely into the mounting.
- After you have finished towing, remove the towing eye **by unscrewing it in the clockwise direction** using a suitable object.
- Insert the cap in the respective recess and press in until it engages.
- Clean the towing eye if necessary and place it back in the vehicle toolkit in the luggage compartment.

D NOTICE

Always screw the towing eye fully and securely into the mounting. Otherwise the towing eye may damage the support during towing starting or towing.

Fitting the towing eye at front

📖 Please refer to **A** and **D** at the start of the chapter on page 162.

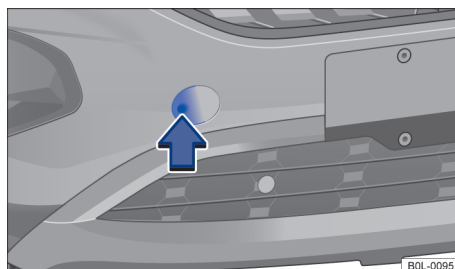

Fig. 131 In the front bumper on the right: removing the cover

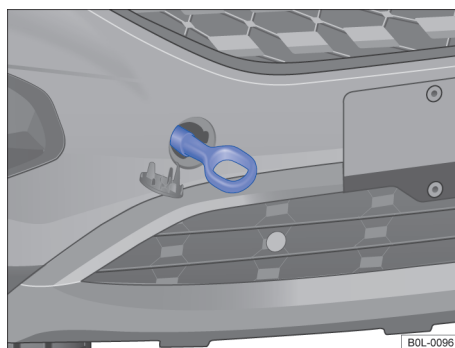

Fig. 132 In the front bumper on the right: screwing in the towing eye

The towing eye must always be kept in the vehicle.

Pay attention to the tips about towing. → page 162

Fitting the front towing eye

- Always use the towing eye supplied in the vehicle toolkit. → page 152
- Press the marked area of the cover in the direction of the arrow → Fig. 131 to release the cover catch.
- Remove the cover, allow it to hang on the vehicle.
- Turn the towing eye **as shown by the arrow in to the threaded hole** and tighten as far as possible → Fig. 132 → **D**. Use a suitable object to screw the towing eye fully and securely into the mounting.

- After you have finished towing, remove the towing eye **by unscrewing it in the clockwise direction** using a suitable object.
- Insert the cap in the respective recess and press in until it engages.
- Clean the towing eye if necessary and place it back in the vehicle toolkit in the luggage compartment.

NOTICE

- If the towing eye is not screwed fully and securely into the mounting, it can tear out of the mounting during towing. The vehicle can be damaged if the towing eye is torn out.

Checking and refilling

Engine compartment

Safety notes for working in the engine compartment

The engine compartment of a motor vehicle is a hazardous area! You should carry out work in the engine compartment only if you know exactly how to perform the required tasks, are aware of the general safety procedures and have access to the correct equipment, service fluids and suitable tools. Failing to carry out work correctly can cause serious injuries. → . In case of any doubt, it should be carried out by a correspondingly qualified workshop

Always park the vehicle on a level and stable surface before working in the engine compartment.

WARNING

Unintentional vehicle movements may cause accidents and serious or fatal injuries.

- Always exercise extreme care and caution when carrying out all work! Appropriate measures must be taken to prevent vehicles from moving. Make sure that the vehicle is standing on a flat surface and that the wheels are blocked if work is carried out under the vehicle, and the vehicle key must be removed from the ignition switch while the wheels are touching the ground.
- Always exercise extreme care and caution when carrying out all work under the vehicle! Additionally support the vehicle with suitable support stands when you are working under the vehicle. The jack is not sufficient for this task and can fail.
- The automatic engine start-stop system must be off.

WARNING

The engine compartment of a motor vehicle is a hazardous area! Accidents and serious or fatal injuries can occur.

- All operations in the engine compartment must be carried out with extreme caution and attention, and must strictly follow the safety regulations, do not take risks!

- Perform work in the engine compartment only if you are familiar with the necessary tasks. Have the necessary work carried out by a suitably qualified workshop if you are uncertain about how to carry out work in the engine compartment. Volkswagen recommends using a Volkswagen dealership.
- Never open or close the bonnet if steam or coolant is escaping. Always wait until you can no longer see or hear steam or coolant coming from the engine compartment.
- Do not open the bonnet until the engine cools down.
- Escaping hot steam or coolant and hot components can cause serious burns.
- The following matters must be paid attention to before opening the engine hatch cover after engine cooling:
 - Switch on the electronic parking brake and move the selector lever to position **P**. Or move the selector lever to neutral.
 - Switch off the ignition and keep the vehicle key in a safe place far enough away from the vehicle so that the engine cannot be started accidentally, especially in vehicles with the system Keyless Access.
 - Always keep children away from the engine compartment and never leave children unsupervised.
- The cooling system is under pressure when the engine is hot. If the cap is opened without due care, coolant can spray out and cause serious burns or fatal injuries.
 - Turn the cap of the coolant expansion tank slowly and very carefully anticlockwise while exerting slight downwards pressure on the cap.
 - If you have to open the cap of the coolant tank, always protect your face, hands, and arms from hot coolant or steam with a large, thick cloth.
- When adding vehicle oil, be careful not to splash the oil into the engine compartment or exhaust system to prevent fire!

WARNING

The high voltage in the electrical system can cause electric shocks and burns. This can result in serious or fatal injuries!

- Never short circuit the electrical system. The 12-volt vehicle battery can explode.

- The following precautions must be observed during engine starting or running to prevent electric shock or injury:
 - Never touch the electrical wiring of the ignition system.
 - Never touch the connections of gas discharge bulbs.

WARNING

There are rotating parts in the engine compartment. This can cause serious injury.

- Never reach into the radiator fan or into the area of the radiator fan. Reach into the fan may result in serious injury. Even if the engine or ignition is switched off. The fan is temperature controlled and could start automatically.
- If the engine is started or running, contact with rotating parts, e.g. multi-wedge belt, generator, and rotor blades of the radiator fan, can cause serious or fatal injuries. Always be extremely cautious.
 - Make sure that body parts, jewellery, ties, loose clothing, and long hair do not get caught up in rotating engine parts. Before starting work, remove any jewellery and ties, tie up long hair, and pull clothes in tightly to avoid them getting caught in the engine.
 - Be very careful and do not press the accelerator pedal carelessly. The vehicle could start moving even if the electronic parking brake is switched on.
- Never leave objects in the engine compartment. Objects left behind can cause functional failure, engine damage and fire.

WARNING

Additional insulating materials in the engine compartment can cause malfunctions, damage to the engine, and fire. This can result in serious or fatal injuries.

- Never cover the engine with blankets or other insulating materials.

WARNING

The vehicle service fluids and some materials in the engine compartment are highly flammable substances, beware of causing fire and casualties!

- Never smoke in the vicinity of the engine compartment.
- Never work in the direct proximity of sparks or naked flames.
- Never spill service fluids onto the engine. These service fluids can cause fire on engine parts, causing injury.
- If you need to work on fuel systems or electrical installations, observe the following:
 - The 12-volt vehicle battery must be discharged.
 - Do not work near warm air units, continuous heaters or other open flames.
- Always have a fully functional and tested fire extinguisher to hand.

NOTICE

Do not add wrong service fluids when adding or changing vehicle service fluids! When refilling or replacing service fluids, ensure that you pour the correct service fluids into the corresponding openings. Otherwise, it is bound to deteriorate the system function, damage the engine!

 Any service fluids leaks from the vehicle are harmful to the environment. You should therefore regularly check the ground underneath your vehicle. If there are patches of oil or other fluids on the ground, the vehicle should be inspected by a suitably qualified workshop. Any spilt service fluids must be disposed of properly. Volkswagen recommends using a Volkswagen dealership.

Preparing the vehicle for working in the engine compartment

Checklist

The following actions should always be carried out in the given order before working in the engine compartment → :

- ✓ Park the vehicle safely on a level and firm surface.
- ✓ Press and hold the brake pedal until the engine stops running.
- ✓ Switch on the electronic parking brake → page 123.

- ✓ Move the selector lever in neutral position → page 103 or the selector lever in position P → page 104.
- ✓ Switch off the engine and remove the key from the ignition. → page 97
- ✓ Allow the engine to cool sufficiently.
- ✓ Always keep children and unrelated persons away from the engine compartment.
- ✓ Secure the vehicle against rolling away.

WARNING

If the described activities for performing work in the engine compartment are not observed, this can lead to accidents. This can result in serious injuries.

- Be sure to strictly follow the above table and safety procedures.

Opening and closing the bonnet

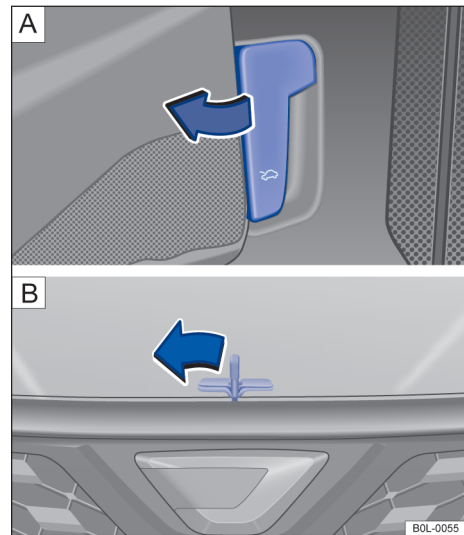

Fig. 133 **A** In the footwell on the driver side: bonnet release level; **B** Above the radiator grille: bonnet control lever

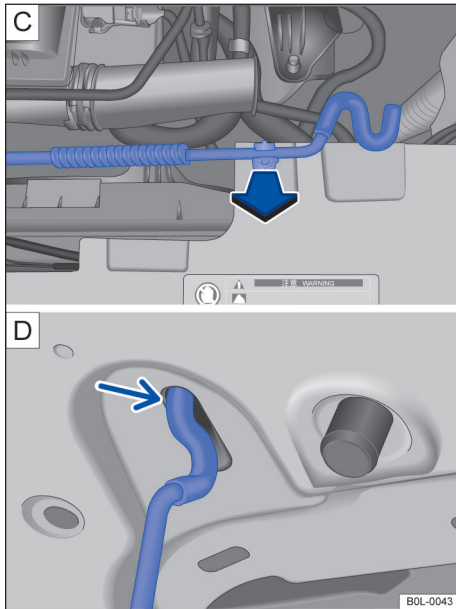

Fig. 134 C In the engine compartment: bonnet stay in the holder; D On the bonnet: holder for bonnet stay

Open the bonnet

- Always fold the wiper arms back onto the windscreen before driving away before opening the bonnet → ⓘ.
- Open the driver door and pull the release lever in the direction of the arrow (marked with symbols ⓘ) → Fig. 133 A. The bonnet is released from the lock carrier catch by spring force → ⚠.
- Lift the bonnet slightly while simultaneously pressing the opening lever in the direction of the arrow → Fig. 133 B to open the bonnet fully.
- Take the bonnet stay out of its holder in the direction of arrow → Fig. 134 C and insert it into the opening → Fig. 134 D (Arrow).

Closing the bonnet

- Lift the bonnet slightly and hold → ⚠.
- Unhook the bonnet stay from the opening and push it into its holder → Fig. 134 C.
- Let the bonnet drop into the catch from a height of about 20 cm, *do not* press it down!

If the bonnet has not closed properly, lift it and then close it again.

Properly closed the bonnet should be flush with the adjacent body. If the bonnet is not closed properly, a corresponding display appears in the instrument cluster display. → page 168

⚠ WARNING

If the bonnet is not closed properly, it can open suddenly while you are driving and completely obscure your view of the road. This can result in accidents and severe or fatal injuries!

- After closing the bonnet, always check that the catch is properly engaged in the lock carrier, closed bonnet must be flush with the surrounding adjacent body.
- If you notice while driving that the bonnet is not closed properly, park the vehicle safely and close the bonnet.
- Therefore, be careful when closing the bonnet to ensure that no one is within bonnet range.

ⓘ NOTICE

- Always fold the wiper arms back onto the windscreen, avoiding damage to the bonnet and wiper arms.
- Always fold the wiper arms back onto the windscreen before driving away.

Display

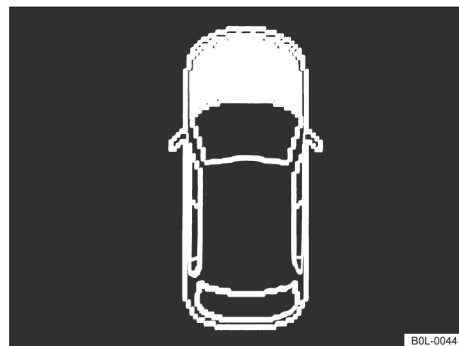

Fig. 135 The display in the instrument cluster: the bonnet is open or is not closed properly

A symbol on the instrument cluster display → Fig. 135 indicates if the bonnet is open or is not closed properly.

STOP Do not drive on! If necessary, lift the bonnet and then close it again.

This symbol is also visible when the ignition is switched off and will go out a few seconds after the vehicle has been locked when all doors are closed.

WARNING

Failure to observe displayed warnings can lead to your vehicle breaking down in traffic and can cause accidents and serious injuries.

- Never ignore warnings.
- Stop the vehicle as soon as possible and when safe to do so.

 Symbol display may be different depending on the type of instrument cluster.

Service fluids and consumables

All service fluids and consumables (e.g. flat-toothed belts, tyres, coolant, engine oils, ignition plug, and 12-volt batteries) **are being constantly further developed**. Have service fluids and consumables replaced by a suitably qualified workshop. Volkswagen recommends using a Volkswagen dealership.

WARNING

Improper use of service fluids and consumables and use of the wrong service fluids and consumable parts may cause accidents, serious injury, burns or toxic!

- Store service fluids only in the closed original container.
- Never store service fluids in empty food containers, bottles, or any other non-original containers as people finding these containers could drink them!
- Keep children away from all service fluids and consumables.
- Always observe and follow the information and warnings on the service fluid packaging.
- When using products that give off harmful fumes, always work outdoors or in a well-ventilated area.

- Never use turpentine, engine oil, fuel, nail varnish remover, or other volatile fluids for vehicle care, because the above materials are toxic and combustible substances, easy to cause fire and explosion.

NOTICE

- Only the vehicle oil suitable for this vehicle can be added! The vehicle oil must be added according to the system function. Adding the wrong vehicle oil may cause serious function failure and damage the engine.
- If optional equipment and other accessories are installed in front of the air inlet, the cooling effect of the engine coolant will be weakened. The ambient temperature is very high, and the engine is easy to overheat when the engine is running under a large load!

 Any service fluids leaks from the vehicle are harmful to the environment! Leakage of vehicle oil must be collected in a suitable container and waste vehicle oil must be properly disposed of in accordance with environmental regulations.

Checking and refilling washer fluid





Fig. 136 In the engine compartment: washer fluid reservoir cap

The washer fluid level should be checked regularly and refilled as necessary.

There is a strainer in the filler throat of the washer fluid reservoir. The strainer keeps large dirt particles away from the washer jets when refilling. The strainer can be removed for cleaning. If the strainer is damaged or the strainer is not

present when the cleaning solution is filled, the dirt will enter the system and block the washer jet.

- Open the bonnet  → page 165.
- The washer fluid reservoir is identified by the  symbol on the cap → Fig. 136.
- Check whether there is enough washer fluid in the reservoir.
- Add washer fluid, must be filled in accordance with the company's regulations. → page 170.
- At low outside temperatures, add a special anti-freeze agent so that the fluid cannot freeze → .

Depending on the equipment, the amount added to the washer fluid tank is approximately 3.0 L.

Specifications for washer fluid

This vehicle has been filled with windscreen washer liquid (freezing point about -17°C) in accordance with the regulations. If the vehicle is used in the cold season and region, the anti-freezing ability of the windscreen washer liquid needs to be improved. The original winter special windscreen washer liquid recommended by the company should be replaced to prevent the freezing of the washer liquid → .

If the vehicle is used in summer and hot areas, it is recommended to use the original summer windscreen washer fluid recommended by our company (freezing point is about -8°C) in order to improve the use economy. If there is still any remaining winter washer liquid in the liquid storage tank, the concentration of the windscreen washer liquid can be reduced by adding an appropriate amount of clean water (non-distilled water).

Since clean water (not distilled water) cannot completely clean the window glass, please choose the appropriate original washer fluid recommended by our company according to the current lowest ambient temperature in the area where the vehicle is used, and make sure to prepare a suitable concentration of washer fluid according to the ratio instructions on the packaging container of the windscreen washer fluid → .

WARNING

Do not mix other inappropriate additives into the windscreen washer fluid, otherwise, oil film may be formed on the window glass, affecting the front vision.

- It is recommended to use the original air windscreen washer fluid recommended by our company.
- Appropriate antifreeze can be added to the windscreen washer fluid if necessary.

NOTICE

- Do not mix the cleaning agent recommended by our company with other cleaning agents. Mixing different windscreen washer fluids can lead to flocculation of ingredients in the fluid and cause clogging of the washer jets.
- When adding washer fluid, do not mix with other vehicle oil, otherwise, it may lead to serious failure and dysfunction.

Engine oil

Introduction

This chapter contains information on the following subjects:

- Engine oil standards 171
- Changing engine oil 172
- Consumption of engine oil 172
- Checking the engine oil level and adding engine oil 173
- Troubleshooting 174

Engine oils are matched to the requirements of the engines, exhaust purification systems, and fuel quality. Due to the way in which a combustion engine works, engine oil always comes into contact with combustion residues and fuel, which has an effect on the ageing process of the oil. The correct engine oil is important for the function and service life of the engine. A special multigrade high-lubricity oil has been filled at the factory and this can normally be used as an all-season oil, except for extreme cold weather.

Like other parts of the vehicle, the engine oil is also in constant development. The authorized dealers of our company have mastered the latest development trends and technical data of the vehicle oil, and it is recommended that the authorized dealers of our company should replace the engine oil.

For information about the lighted warning lights and indicators, see Troubleshooting at the end of this chapter. → page 174

⚠ WARNING

If engine oil is handled without due care, this can cause serious burns to the body. This can result in serious or fatal injuries!

- Always wear eye protection when operation.
- Engine oil is toxic, must be stored in a safe place. Always keep engine oil out of the reach of children!
- Engine oil must be stored in its original container and spent oil must also be stored in its original container before disposal.
- Never store engine oil in empty food containers, bottles, or any other non-original containers as people finding these containers could drink them!
- Avoid regular contact with engine oil in order to prevent damage to the skin. Wash your skin with soap and water after working with engine oil.
- The engine oil temperature is very high when the engine is running, beware of scald skin, should let the engine fully cool before operation.

 Leaking or spilt engine oil can pollute the environment. Spilt service fluids must be collected and disposed of properly and with respect for the environment.

Engine oil standards

📖 Please refer to ⚠ and Ⓜ on page 165 and ⚠ at the start of the chapter Ⓜ on page 171.

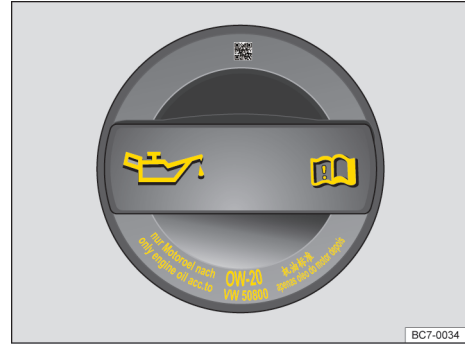

Fig. 137 Sticker showing the engine oil standard (illustration)

It is strongly recommended to use only the oil approved by us for the engine of the vehicle you purchase → Ⓜ.

The quality of the oil on the market varies greatly, therefore, the selection of engine oil must be careful.

While choosing the standard engine oil for your vehicle engine, you must also use high quality unleaded gasoline conforming to the GB17930 standard.

Permitted engine oil standards

Permitted engine oil standards → Ⓜ	
Engine type	Regular maintenance (depending on driving time/mileage)
Engine	Type 0W-20 oil conforms to VW 508 00

For engine oil that need to be filled with 0W-20 oil conforming to VW 508 00, the oil filling cap may be marked with the standard of engine oil that can be filled, and the engine performance can be maintained in normal condition by using this standard oil. → Fig. 137

Ⓜ NOTICE

If you do not know the engine type and the engine oil specifications that can be refilled, please consult dealership. ▶

- Use only engine oils that meet the quality requirements of the corresponding VW standard for refilling. Use of other engine oil may damage the engine!

NOTICE

- Do not add any other lubricants to the engine oil! Vehicle breakdown and damage caused by the use of other lubricants are not covered by the quality guarantee.
- You must use the engine oil suitable for the engine of the vehicle you purchased according to the engine oil specifications listed in the above table. Using other engine oil specifications may damage the engine!

Changing engine oil

 Please refer to  and  on page 165 and  at the start of the chapter on page 171.

The engine oil must be changed regularly and in accordance with the service interval according to the Maintenance Manual.

You should always have engine oil and filter changes performed by a suitably qualified workshop. Volkswagen recommends using a Volkswagen dealership. The same is true for the disposal of waste motor oil, which is also recommended by dealership.

Detailed information on the engine oil service interval can be found in the Maintenance Manual.

Additives in the engine oil can cause new engine oil to discolour quickly. This is normal and does not mean that the engine oil should be changed more frequently.

WARNING

Under special circumstances, if you have to change the engine oil, the following precautions must be observed:

- Always wear eye protection when changing engine oil.
- Always allow the engine to cool down completely before changing the engine oil.

- Keep your arms horizontal when unscrewing the oil drain plug with your fingers to prevent the emerging oil from running down your arm.
- Use a suitable container when draining the used oil. It must be at least large enough to hold the entire filling quantity of engine oil.
- Never store engine oil in empty food containers, bottles, or any other non-original containers as people finding these containers could drink them!
- Engine oil is toxic, must be stored in a safe place. Always keep engine oil out of the reach of children!

 Before replacing engine oil, find out where you can dispose of the waste oil nearby.

 Waste oil must be treated strictly in accordance with the relevant provisions of the environmental protection law. Because of the waste oil to the environment and water pollution, it is not allowed to pour waste oil in gardens, woods, streets, rivers or sewers.

Consumption of engine oil

 Please refer to  and  on page 165 and  at the start of the chapter on page 171.

Depending on vehicle service conditions, the oil consumption rate of each engine may be different, and it will also change with the life of the engine.

According to the driving mode and vehicle conditions, The maximum oil consumption rate of this vehicle is not more than 0.5 L/1,000 km- The oil consumption rate of a new car may be slightly higher within the first 5,000 km. Therefore, the engine oil level must be checked regularly, preferably when adding fuel and before a long drive.

In summer, when driving long distances on the highway, or by towing, or in mountainous areas, the oil level must be located at the upper limit of zone → Fig. 138  during the engine operating in harsh conditions.

Checking the engine oil level and adding engine oil

📖 Please refer to ⚠ and ⌚ on page 165 and ⚠ at the start of the chapter on page 171.

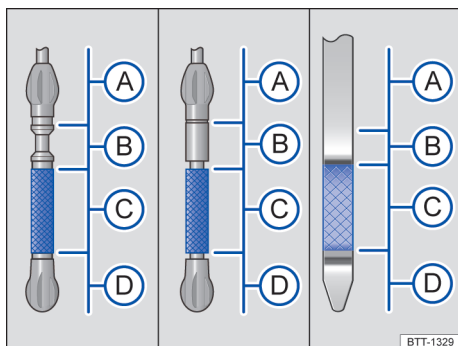

Fig. 138 Engine oil level markings on the oil dipstick (illustration)

Fig. 138 Note:

- Ⓐ Engine oil level is too high - Please contact dealership.
- Ⓑ Do not add engine oil.



Fig. 139 In the engine compartment: engine oil filler opening cap (illustration)

- Ⓒ Engine oil level in the normal range.
- Ⓓ Engine oil level too low - Add engine oil.

Checklist

The steps should be carried out in the given order only:→ ⚠:

1. Park the vehicle **on a level surface** with the engine at operating temperature.
2. Switch off the engine and wait a few minutes for engine oil to flow back into the sump.
3. Open the bonnet ⚠→ page 165.
4. Identify the engine oil filler opening and oil dipstick. The engine oil filler opening can be recognised by the symbol on the cap→ Fig. 139, and the oil dipstick has a coloured handle. If you are not clear about the location of the lid and oil dipstick, Volkswagen recommends using a Volkswagen dealership.
5. Pull the oil dipstick out of the guide tube and wipe it off with a clean cloth.
6. Insert the oil dipstick into the guide tube again as far as it will go. If there is a marking on the oil dipstick, this marking must fit in the corresponding groove at the top end of the guide tube when inserting.
7. Pull out the oil dipstick again and read the engine oil level on the dipstick as follows:→ Fig. 138
 - Ⓐ **Do not** starting the engine→ ⌚. Volkswagen recommends using a Volkswagen dealership.
 - Ⓑ **Do not** add engine oil→ ⌚. Go to Step 16.
 - Ⓒ It is essential to refill engine oil. When the vehicle is working particularly hard, the engine oil level should be kept within **the upper permissible area**. Go to Step 8 or 16.
 - Ⓓ **Must** add engine oil. Go to Step 8.
8. After reading off the engine oil level, push the oil dipstick back into the guide tube as far as it will go.
9. Unscrew the engine oil filler opening cap→ Fig. 139
10. It is strongly recommended to use only the oil approved by us for the engine of the vehicle you purchase→ page 171 and fill engine oil gradually in small quantities, not more than 0.5 L at a time. ▶

Checklist (Continued)

11. In order to avoid overfilling, wait for at least 1 minute after each refill step to allow the engine oil to flow into the sump.
12. Read the engine oil level from the dipstick again before refilling with a further small quantity of engine oil → ①.
13. After filling, the engine oil level should be in the middle of the area → Fig. 138(C). The engine oil level should not be above the area (C) into the area (B), but must not be in the area above (A) → ①.
14. If you have added an excessive amount of engine oil by accident and the engine oil level is thus above area → Fig. 138(A), **do not start the engine**. Seek expert assistance.
15. After refilling, close the engine oil filler opening with the cap.
16. Insert the oil dipstick into the guide tube again as far as it will go. If there is a marking on the oil dipstick, this marking must fit in the corresponding groove at the top end of the guide tube when inserting.
17. Closing the bonnet  → page 165.

WARNING

When refilling, engine oil can spill or overflow and ignite if it gets onto hot engine parts. This can cause fires or burns. This can result in serious or fatal injuries.

- Spilled oil on cold engine components, the oil temperature will rise when it's running, easy to spontaneous combustion.
- After filling the oil, make sure to tighten the oil filler opening cap and insert the oil dipstick into the guide tube correctly to prevent oil from spilling over to the hot components of the engine when the engine is running.

NOTICE

- Do not start the engine if the engine oil level is in the area → Fig. 138(A)! Seek expert assistance, or this can damage the engine and catalytic converter.
- Do not add wrong service fluids when adding or changing vehicle service fluids! The use of incorrect oil could result in serious malfunctions and engine damage.

 Engine oil level shall not be in the area → Fig. 138(A). Otherwise the oil will enter the crankcase ventilation unit and enter the atmosphere through the exhaust unit.

Troubleshooting

 Please refer to  and  on page 165 and  at the start of the chapter on page 171.

and Engine oil pressure too low

The warning lamp flashes red and a message is shown: **Engine oil pressure: Pull over! Pay attention to the messages on board.**

Do not drive on!

Switch off the engine and check the engine oil level. → page 173 If the warning lamp is flashing even when the engine oil level is correct, *do not* drive on or leave the engine running. The engine could otherwise be damaged. Seek expert assistance. 

Coolant

Introduction

This chapter contains information on the following subjects:

- ◀ – Coolant specification 175
- Checking the coolant level and refilling coolant 176
- Troubleshooting 177 ▶

Do not work on the cooling system unless you are familiar with the task, aware of the general safety procedures and have the correct equipment, service fluids and suitable tools → ⚠. In case of any doubt, it should be carried out by a correspondingly qualified workshop

⚠ WARNING

Coolant is toxic!

- Engine coolant must be stored in its original container and stored in a safe place.
- Never store coolant in empty food containers, bottles or any other non-original containers as people finding these containers may then drink the coolant. Poisoning by mistake!
- Always keep coolant out of the reach of children .
- The coolant must be prepared according to the current lowest ambient temperature in the area where the vehicle is used.
- Coolant can freeze at extremely cold outside temperatures, causing the vehicle to break down. This can lead to the heating no longer working in the vehicle. Vehicle occupants with inadequate winter clothing could freeze to death.

 Coolant and coolant additives can pollute the environment. Therefore, spilt service fluids must be collected and disposed of properly and in an environmentally responsible way.

Coolant specification

 Please refer to ⚠ and ⓘ on page 165 and ⚠ at the start of the chapter on page 175.

This vehicle has been filled with coolant in accordance with the regulations (G12 EVO). The coolant is violet in colour.

The freezing point of the coolant is below -35°C, and can prevent corrosion of alloy parts of the cooling system and scale production of the system, and improve the boiling point of the coolant.

If the vehicle is used in the cold season and area, it is necessary to improve the anti-freezing ability of the coolant, so the corresponding type of orig-

inal coolant should be selected according to the current lowest ambient temperature of the vehicle use area.

In order to obtain the optimum anti-corrosion effect, it is recommended to fill the cooling system with our original coolant → ⓘ.

⚠ WARNING

Inadequate frost protection of the engine cooling system can lead to engine failure, which can lead to injury or death.

- Make sure that the coolant additive is always adapted corresponding to the ambient temperature
- Coolant can freeze at extremely cold outside temperatures, causing the vehicle to break down. This can lead to the heating no longer working in the vehicle. Vehicle occupants with inadequate winter clothing could freeze to death.

ⓘ NOTICE

When adding coolant additives, never mix genuine coolant additives with other coolant additives that have not been approved by Volkswagen, otherwise, the engine and its cooling system may be damaged.

- If the liquid in the coolant expansion tank is not violet but brown, the suitable coolant has been mixed with another unsuitable coolant. In this case, the coolant must be replaced, otherwise, it may seriously deteriorate the engine performance and damage the engine.

 Coolant and coolant additives can pollute the environment. Spilt service fluids must be collected and disposed of properly and with respect for the environment.

Checking the coolant level and refilling coolant

📖 Please refer to ⚠️ and ⌚ on page 165 and ⚠️ at the start of the chapter on page 175.

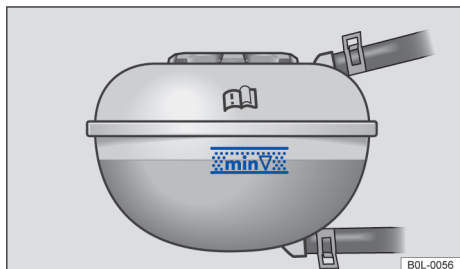

Fig. 140 In the engine compartment: markings on the coolant expansion tank (illustration).



Fig. 141 In the engine compartment: coolant expansion tank cap (illustration)

If the engine coolant level is too low, the warning lamp will flash.

Preparations

- Park the vehicle on a firm and level surface.
- Allow the engine to cool down → ⚠️.
- Open the bonnet ⚠️ → page 165.
- The coolant expansion tank is identified by the symbol 📖 on the cap → Fig. 141.

Checking engine coolant level

The coolant may be above the marked area upon delivery of new vehicles or after repairs to the cooling system. This is normal. The coolant does not have to be sucked off.

- When the engine is cold, check the coolant level at the side markings of the coolant expansion tank. → Fig. 140
- Have coolant added if the fluid level in the coolant expansion tank is below the minimum marking ("min"). When the engine is warm, the engine coolant level may be slightly above the upper mark ("max").

Warning lamp



If the engine coolant level is too low, the warning lamp will flash.

🚫 **Do not drive on!** Stop as soon as practicable and safe to do so. Seek expert assistance.

Adding coolant

If the coolant level is too low and there is no qualified workshop nearby, the following matters when adding the coolant by yourself:

- Always protect your hands and arms from hot coolant or steam with a large, thick cloth if you have to open the cap of the coolant tank.
- Unscrew the lid carefully → ⚠️.
- Fill only with **in** coolant according to Volkswagen's specification (→ page 174) → ⌚.
- Do not add coolant if there is no longer any coolant visible in the coolant expansion tank. This may damage the engine! If there is no coolant in the engine coolant expansion tank, **do not drive on**, seek expert assistance.
- If there is any coolant left in the coolant expansion tank, add the coolant until the level remains stable.
- The coolant level must be within the marked area of the engine coolant expansion tank. → Fig. 140 **Do not fill coolant above the top edge of the marked area on the coolant tank** → ⌚.
- Close the cap tightly.
- If in an emergency you do not have access to coolant with the required specification → page 174, do not use any other coolant additive, the qualified workshop shall be contacted immediately for treatment, and the

original coolant that meets the local temperature requirements shall be filled as soon as possible!

WARNING

Escaping hot steam or coolant can cause serious burns.

- Never open the bonnet if you can see or hear steam or coolant coming out of the engine compartment! Always wait until you can no longer see or hear steam or coolant coming from the engine compartment.
- Do not open the bonnet until the engine cools down. Touching hot components can burn your skin.
- The following matters must be paid attention to before opening the bonnet after engine cooling:
 - Switch on the electronic parking brake and move the selector lever to position **P** Move the selector lever to neutral.
 - Remove the vehicle key from the ignition lock.
 - Always keep children away from the engine compartment and never leave children unsupervised.
- The cooling system is under pressure when the engine is hot! At this time, do not open the coolant expansion tank cover, otherwise, the coolant may be ejected from the expansion tank, serious scald or injury to the operator.
 - Turn the cap of the coolant expansion tank slowly and very carefully anticlockwise while exerting slight downwards pressure on the cap.
 - Always protect your face, hands and arms from hot coolant or steam when you have to open the cap of the expansion tank with a large, thick cloth.
- Do not spill oil on engine components or exhaust system when filling vehicle oil! Otherwise, it may cause a fire. Glycol in engine coolant can ignite under certain conditions.

NOTICE

- Fill only with original coolant according to Volkswagen's specification! Other types of coolant may not meet the requirements of the

vehicle and may cause corrosion damage in the engine or even lead to failure of the engine.

- Add coolant shall not exceed the upper limit of the marked area. Otherwise, when the engine reaches the hot state, the excess coolant may overflow under the pressure of the system and damage the components in the engine compartment.
- If the coolant loss is large, the engine is not *cooling completely*, do not add coolant! In this case, it indicates that there is leakage fault in the cooling system. Please contact the qualified workshop to check the system as soon as possible, otherwise, the engine will be damaged.
- Do not add coolant when the coolant in the expansion tank is completely exhausted! Otherwise air may enter the cooling system. Do not drive on. Seek expert assistance! Otherwise it may cause engine damage!
- Must fill the vehicle oil according to the system function, do not add the wrong oil! Otherwise, this can cause serious malfunctions and damage the engine. <

Troubleshooting

 Please refer to  and  on page 165 and  at the start of the chapter on page 175.

Engine coolant

The warning lamp flashes red.

The engine coolant temperature is too high or the coolant level is too low.

Do not drive on!

Stop as soon as practicable and safe to do so.

- Switch off the engine.
- Allow the engine to cool down.

Engine cooling system:

- Check the coolant level → page 174.

Do not drive on or leave the engine running if the warning lamp does not go out even though the coolant level is correct.

- Seek expert assistance. <

Brake fluid

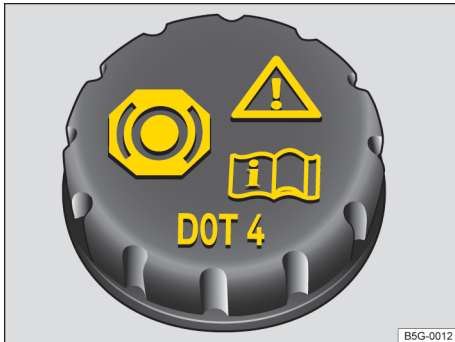

Fig. 142 In the engine compartment: cap of the brake fluid reservoir

Brake fluid will gradually absorb water from the surrounding air over the course of time. The brake system will be damaged if there is too much water in the brake fluid. The boiling point of the brake fluid is also considerably reduced by the water content. Heavy use of the brakes may cause a vapour lock in the brake system if the water content is too high. Vapour locks reduce the braking efficiency, considerably increase braking distance and can even cause the brake system to fail completely. Your own safety and that of other road users depends on having a brake system that functions properly at all times → ⚠.

Brake fluid specification

Volkswagen has developed a brake fluid that has been optimised for the brake system in the vehicle. To ensure the best possible operation of the brake system, only the brake fluid recommended by the original manufacturer is allowed to be used.

Brake fluid level

The brake fluid level must always be between the MIN (minimum) and MAX (maximum) markings on the brake fluid reservoir → ⚠.

The brake fluid level cannot be checked accurately in all models as a flap or engine components may partially conceal the brake fluid container. If the brake fluid level cannot be read exactly, please seek assistance from a suitably qualified workshop. Volkswagen recommends using a Volkswagen dealership.

The brake fluid level drops slightly during vehicle operation as the brake pads wear and the brakes are automatically adjusted. This is normal, and there is no need to worry about it.

⚠ Brake fluid level

The indicator light lights up red

Low brake fluid level is too low.

🛑 **Do not drive on!** Checking the brake fluid level.

Seek expert assistance if the brake fluid level is too low.

Changing the brake fluid

These should be changed only by a qualified workshop. Volkswagen recommends using a Volkswagen dealership. Further information can be obtained from a correspondingly qualified workshop. Volkswagen recommends using a Volkswagen dealership. Have the brake system filled only with new brake fluid.

⚠ WARNING

The brakes may fail or the braking efficiency may be reduced if the brake fluid level is too low or if unsuitable brake fluid is used!

- Have the brake system and brake fluid level checked regularly.
- The brake fluid should be changed regularly.
- Heavy use of the brakes may cause a vapour lock in the brake system if the brake fluid is used for a long time. Vapour locks reduce the braking efficiency, considerably increase braking distance and can even cause the brake system to fail completely.
- Only brake fluid that conforms with the required specification should be used. Old brake fluid or unsuitable brake fluid can reduce the braking efficiency or even lead to total brake failure in the brake system or components! In this way, Volkswagen does not assume any responsibility (including quality guarantee) for the resulting vehicle breakdown and damage. Before using a particular brake fluid, check that the specifications printed on the container correspond to the vehicle requirements.
- The use of other brake fluid or inferior brake fluid will worsen the brake function, reduce the brake efficiency!
- New brake fluid must be added.

WARNING

Brake fluid is toxic!

- Never store brake fluid in empty food containers, bottles or any other non-original containers as people finding these containers could drink the brake fluid in them!
- Always keep brake fluid out of the reach of children and only in the closed original container to avoid poisoning accidents.

NOTICE

Brake fluid that has leaked or been spilled will attack vehicle surfaces. The vehicle paintwork, plastic parts and tyres could be damaged as a result. It should be promptly wiped off the spilled brake fluid on the paint and other vehicle components.



Brake fluid can pollute the environment. Any spilt service fluids must be cleaned up and disposed of properly.

12-volt vehicle battery

Introduction

This chapter contains information on the following subjects:

- Checking the battery 180
- Charging, replacing, disconnecting and connecting the battery 181
- Troubleshooting 182

The 12-volt vehicle battery is a component of the electrical system.







You should only carry out work on the electrical system if you know exactly how to perform the required tasks, are aware of the general safety procedures and have access to the correct equipment, service fluids and suitable tools. →  All work should be carried out by a correspondingly qualified workshop. Volkswagen recommends using a Volkswagen dealership. Failing to carry out work correctly can cause serious injuries.

Information on warning and indicator lamps that light up can be found in the troubleshooting sections at the end of the chapter. → page 182

Installation position of 12-volt vehicle battery

The 12-volt vehicle battery is located in the engine compartment.

Explanation of the warnings on the 12-volt vehicle battery

-  Always wear eye protection!
-  Electrolyte is very corrosive and caustic. Always wear protective gloves and eye protection!
-  No fire, sparks, naked lights or smoking!
-  A highly explosive mixture of gases is given off when the 12-volt vehicle battery is charging!
-  Always keep children away from electrolyte and the 12-volt vehicle battery!
-  Always observe the owner's manual!

WARNING

Any work on the 12-volt vehicle battery and the electrical system can cause serious chemical burns, fire or electric shocks. Read and always observe the warnings on the 12-volt vehicle battery:

- Switch off the ignition and all electrical consumers before carrying out any work on the 12-volt vehicle battery and also disconnect the negative cable from the 12-volt vehicle battery.
- Children should always be kept away from electrolyte and the 12-volt vehicle battery.
- Always wear eye protection and protective gloves.
- Electrolyte is very corrosive and caustic. Improper handling can burn the skin and even cause blindness. When working with the 12-volt vehicle battery, ensure that your hands, arms and face in particular are protected from acid spillage.
- No smoking, no naked flames or sparks in the workplace.
- When handling cables and electrical equipment, avoid generating sparks and electrostatic discharge.
- Never short circuit battery terminals.
- Never charge damaged 12-volt vehicle battery. Damaged vehicle battery may explode. Replace the damaged 12-volt vehicle battery immediately.

- Never charge a 12-volt vehicle battery which is frozen or has been frozen. A discharged 12-volt vehicle battery can already freeze at temperatures around 0°C. The 12-volt vehicle battery must be replaced if it has ever frozen.

NOTICE

- Do not expose the 12-volt vehicle battery to direct sunlight for an extended period. Ultra-violet radiation can damage the battery housing.
- Protect the 12-volt vehicle battery against frost if the vehicle is left standing for extended periods.

 When you start the engine after the 12-volt battery has been totally discharged or after jump starting, you may find that system settings (time, date, personal convenience settings and programming) have been changed or deleted. Check and correct the settings as necessary once the 12-volt vehicle battery has been sufficiently charged.

Checking the battery

 Please refer to  and  on page 165 and  and  at the start of the chapter on page 179.

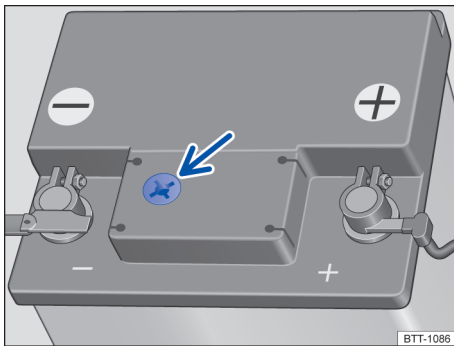



Fig. 143 On the top of the 12-volt vehicle battery: battery window (illustration)

The electrolyte level of the 12-volt vehicle battery should be checked regularly in high-mileage vehicles, in hot countries and in older 12-volt vehicle batteries. The 12-volt vehicle battery is otherwise maintenance-free.

Preparations

- Instructions for safe operation in engine bay. → page 165
- Open the bonnet  → page 165.

Checking the electrolyte level (12-volt vehicle battery with battery window)

- Ensure that enough light is available for you to clearly see the colour indicator in the round window on the top of the 12-volt vehicle battery (Arrow) → Fig. 143 Do not use naked flames or objects flashing sparks as lighting.
- The colour displayed in the round battery window changes according to the electrolyte level in the 12-volt vehicle battery.

Light yellow or without colour The electrolyte level of the 12-volt vehicle battery is too low. Have the 12-volt vehicle battery replaced by a correspondingly qualified workshop. Volkswagen recommends using a Volkswagen dealership.

black jump lead The electrolyte level of the 12-volt vehicle battery is correct.

WARNING

Any work on the 12-volt vehicle battery and the electrical system can cause serious chemical burns, fire or electric shocks!

- Always wear protective gloves and eye protection!
- Electrolyte is very corrosive and caustic. Improper handling can burn the skin and even cause blindness. When working with the 12-volt vehicle battery, ensure that your hands, arms and face in particular are protected from acid spillage.
- Never tilt the 12-volt vehicle battery. Electrolyte may spill out of the gas vents and cause severe burns.
- Never open a 12-volt vehicle battery.
- If acid comes into contact with the eyes or skin, rinse the affected area gently with water for a few minutes. Then consult a doctor immediately.
- If you drink electrolyte by mistake, consult a doctor immediately!

Charging, replacing, disconnecting and connecting the battery

📖 Please refer to ⚠️ and ⌚ on page 165 and ⌚ and ⌚ at the start of the chapter on page 179.

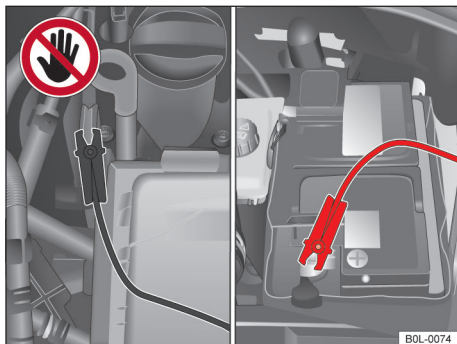

Fig. 144 Engine compartment: port for charging device or auxiliary starting cable

If you suspect that the 12-volt vehicle battery is damaged or faulty, go to a correspondingly qualified workshop and have the 12-volt vehicle battery checked. Volkswagen recommends using a Volkswagen dealership.

Charging the 12-volt vehicle battery

As the technology used in factory-fitted 12-volt vehicle batteries requires voltage-limited charging.→ ⚠️. The 12-volt vehicle battery should be charged by a correspondingly qualified workshop.

Precondition: **Only use the charging equipment of maximum charging voltage 14.8 volts.** The connecting cable of the battery remains connected.

The battery is located in the engine compartment.

- Switch all electrical consumers off.
- Open the bonnet.→ page 165
- Lift the cover plate on the positive terminal.→ Fig. 144
- Clamp the electrode clip of the charging device to the proper grounding position on the vehicle body and the positive terminal (+) of the battery according to the regulations.
- Plug the power cable from the charging device into the power outlet and switch on the device.

- At the end of charging: Switch off the charging device, then unplug the power from the socket.
- At this point, remove the electrode clamp of the charging device.
- Close the cover on the positive terminal.
- Close the bonnet.→ page 165

Replacing the 12-volt vehicle battery

The 12-volt vehicle battery has been developed to suit the conditions of its installation location and has special safety features. If you must replace the battery, you should consult qualified workshop about the electromagnetic compatibility, size, maintenance, capacity and safety features of the new battery before purchasing the battery. Volkswagen recommends using a Volkswagen dealership.

Only maintenance-free 12-volt vehicle batteries compliant with the standards TL 825 06 and VW 750 73 should be used. These standards must be dated October 2014 or later.

The 12-volt vehicle battery must always be replaced by a workshop qualified to do this, as the vehicle electronics must be adapted as part of the replacement process. Only workshops qualified to do this have the technology required to carry out this adjustment and also the correct replacement batteries.

Disconnecting the 12-volt vehicle battery

, please note the following if the 12-volt vehicle battery has to be disconnected from the electrical system in the vehicle:

- Switch all electrical consumers off.
- Unlock the vehicle before disconnecting the battery.
- First disconnect the negative cable and then the positive cable→ ⚠️.

Connecting the 12-volt vehicle battery

- Switch all electrical consumers off before connecting the 12-volt vehicle battery.
- First reconnect the positive cable and then the negative cable→ ⚠️.

Various indicator lamps may light up after the 12-volt vehicle battery has been connected and the ignition is switched on. They will go out if you drive a short distance at a speed of around 15 km/h to 20 km/h. If the indicator lamps stay ▶

lit, the vehicle should be checked by a suitably qualified workshop. Volkswagen recommends using a Volkswagen dealership.

If the 12-volt vehicle battery was disconnected for an extended period, the system may not be able to calculate or correctly display the time when the next service is due. → page 13

Automatic switch-off for electrical consumers

If the 12-volt vehicle battery is subject to high loads, the intelligent onboard supply management system automatically performs various measures to prevent discharge of the 12-volt vehicle battery:

- The idling speed is increased so that the alternator provides more electricity.
- The performance of large electrical consumers may be reduced or they may be switched off completely.
- The USB power supply to the socket may be interrupted briefly while the engine is being started.

If the ignition is switched on for an extended period when the engine is switched off or the side or parking lights are switched on for a long time when the vehicle is parked, the intelligent onboard supply management system cannot always prevent discharge of the 12-volt vehicle battery.

Discharge of 12-volt vehicle battery

- By long standing periods without running the engine, especially if the ignition is switched on.
- Through use of electrical consumers when the ignition is switched off.

WARNING

Use of a 12-volt vehicle battery that does not have the same specifications and dimensions as the factory-fitted 12-volt vehicle battery can lead to short circuits or cause a fire. This can result in serious or fatal injuries!

- Always use a maintenance-free and leak-proof 12-volt vehicle battery that has the same specifications and dimensions as the factory-fitted 12-volt vehicle battery.

WARNING

A highly explosive mixture of gases is given off when the 12-volt vehicle battery is charging!

- 12-volt vehicle batteries should only be charged in well-ventilated spaces.
- Never charge a 12-volt vehicle battery which is frozen or has been frozen! Note that discharged 12-volt vehicle batteries can already freeze at temperatures of around 0°C.
- The 12-volt vehicle battery must be replaced if it has ever frozen.
- Incorrectly connected cables can cause a short circuit. First connect the positive cable and then the negative cable.





NOTICE

- Never connect or disconnect the 12-volt vehicle battery if the ignition is switched on or the engine is running! Do not use batteries that do not match the technical specifications of the vehicle; otherwise, the electrical system or electronic components of the vehicle may be damaged, resulting in other failures, such as automatic engine start-stop system failure.
- If accessories that supply electric power are connected to the 12-volt socket to charge the 12-volt vehicle battery, this can damage the electrical system and the electronic components and lead to electrical malfunctions.

 Dispose of the 12-volt vehicle battery in accordance with the relevant regulations. 12-volt vehicle batteries may contain toxic substances such as sulphuric acid and lead.

 Electrolyte can pollute the environment! Clean up any service fluid leakages and dispose of them properly according to relevant regulations. <

Troubleshooting

 Please refer to  and  on page 165 and  and  at the start of the chapter on page 179.

12-volt vehicle battery

The warning light lights up red.

The engine failed. Do not charge the 12-volt vehicle battery when the engine is running.

Switch off any electrical consumers that are not required. Seek expert assistance.

The start/ stop system cannot start the engine. → page 101 <

Wheels and tyres

Tyre monitoring system

Introduction

This chapter contains information on the following subjects:

- Tyre Pressure Loss Indicator 184
- Troubleshooting for Tyre Pressure Loss Indicator 185

The tyre pressure monitoring system alerts the driver when the tyre pressure is too low.

This vehicle is equipped with two different tyre pressure monitoring systems, the distinguishing characteristics are as follows:

Indirect tyre pressure monitoring

- Different parameters (especially rolling circumference) of all wheels are monitored by ABS sensors (indirect measurement).

WARNING

The intelligent technology of tyre pressure monitoring system cannot exceed the specified limit, and can only work within the limits of the system. Improper wheel and tyre handling can result in a sudden loss of tyre pressure, cracked tread, or even a blown tyre!

- Check the tyre pressure regularly and always maintain the specified pressure. → page 189
If the tyre pressure is too low, it is possible that the tyre temperature will increase to such an extent when driving that the tread peels off and the tyre bursts.
- The cold pressure of the tyre must conform to the value listed on the tyre pressure label. → page 189
- Check the tyre pressure regularly when the tyres are cold and adjust the tyre cold pressure according to the recommended tyre pressure of the vehicle you purchase. → page 189
- Check the tyres regularly for damage and wear.

- Never exceed the top speed and load permitted for the fitted tyres.

WARNING

Different tyre pressure or too low tyre pressure may cause tyre failure, vehicle out of control, easy to cause casualties!

- Stop as soon as the light is  on and check the condition of all tyres. → page 189
- Different or low tyre pressure is bound to aggravate tyre wear, reduce vehicle stability, prolong the braking distance.
- Tyres with different or lower air pressure can suddenly malfunction, causing the tyre to burst and the vehicle to lose control.
- The driver must ensure that the correct air pressure is maintained on all tyres. The tyre pressure plate lists the prescribed tyre pressure. → page 189
- The tyre pressure monitoring system can function properly when all cold tyres maintain correct pressure.
- All tyre pressure must be properly adjusted for vehicle load. → page 189
- Make sure all tyres are charged to the correct air pressure before driving. → page 189
- If the tyre pressure is too low, it is possible that the tyre temperature will increase to such an extent when driving that the tread peels off and the tyre bursts.
- Excessive speeds and overloading of the vehicle can cause overheating and sudden tyre damage including tyre bursts.
- Whether the tyre pressure is too high or too low, the tyres will wear prematurely and the car will not handle well.
- If the tyre is not flat and it is not necessary to change the wheel immediately, drive at low speed to the nearest correspondingly qualified workshop and have the tyre pressure checked and corrected. → page 189
- Always adapt the Tyre Pressure Loss Indicator correctly.

 If the tyre pressure is too low, this will increase fuel consumption and tyre wear.

 When new tyres are driven at high speeds for the first time, they can expand slightly and trigger a one-off tyre pressure warning. ▶

i Old tyres should only be replaced by tyres that have been approved by Volkswagen for the vehicle type.

i Do not rely only on the tyre monitoring system! Check your tyres regularly to ensure that they are properly inflated and have no signs of damage, such as punctures, cuts, cracks, and blisters. Remove any objects that become embedded in the tyre tread but have not penetrated into the body of the tyre itself.

Tyre Pressure Loss Indicator

📖 Please refer to **▲** at the start of the chapter on page 183.

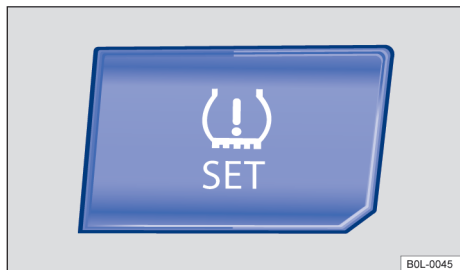

Fig. 145 On Centre console: tyre pressure monitoring button

Function description

The Tyre Pressure Loss Indicator is a tyre monitoring system and uses data from the ABS sensors and other functions to check the speed of rotation and the rolling circumference of the individual wheels when the vehicle is in motion. If the tyre pressure of one or more wheels changes, the e Tyre Pressure Loss Indicator gives an alarm.

However, the following situations can also lead to a change in the rolling circumference:

- If the tyre pressure has been changed.
- If the tyre pressure is too low.
- If the tyre has structural damage.
- If the vehicle is loaded more heavily on one side.
- If snow chains have been fitted.
- If a temporary spare wheel has been fitted.
- If one wheel per axle has been changed.

The Tyre Pressure Loss Indicator (⚠) may react with a delay or not display anything at all in the event of a sporty driving style, when driving on snow-covered or icy roads or unpaved roads or when driving with snow chain.

The Tyre Pressure Loss Indicator shows a change in rolling circumference of the tyres with the indicator lamp (⚠) in the instrument cluster.

◀ The recommended tyre pressure for the factory-fitted tyres is indicated on the tyre pressure sticker on the driver's door pillar. → page 189

The tyre pressure of all tyres including the spare wheel or temporary spare wheel must be checked monthly on a cold tyre and correspond to the vehicle manufacturer's specifications on the tyre pressure sticker. If the tyre size of the mounted tyres differs from the specifications on the type plate or tyre pressure sticker, the correct tyre pressure must be determined.

The tyre monitoring system does not remove the need for regular maintenance and inspection of tyres. The driver is responsible for ensuring the correct tyre pressure is maintained at all times, even if the tyre monitoring system does not give any warning that the tyre pressure is too low.

The tyre monitoring system additionally has a fault indicator that issues a warning if the system is not functioning properly. (⚠). When the vehicle is started, if the system detects a fault, (⚠)The indicator lamp flashes for about 1 minute and then remains lit continuously.

If the tyre monitoring system indicates a malfunction, the tyre pressure cannot be monitored correctly. A malfunction of the Tyre Pressure Loss Indicator can have various causes, e.g. due to replacement of a wheel or tyre. When a wheel or tyre has been replaced, (⚠)check whether the warning lamp is indicating a system malfunction to ensure that the tyre monitoring system is functioning properly. → page 185

Synchronising the Tyre Pressure Loss Indicator

- Switch on the ignition.
- When all four tyre pressures correspond to the required values, tap (Ⓜ) → Fig. 145 until the system emits a confirmation sound.

After an extended driving time and driving at different speeds, the system will automatically learn the new values and monitor them. ▶

The Tyre Pressure Loss Indicator must be re-synchronised under the following conditions:



- If the tyre pressures have been changed.
- If one or more wheels have been changed.
- If the wheels are swapped over, e.g. from front to rear.

The Tyre Pressure Loss Indicator may only be re-synchronised if all the tyres have been filled at the correct tyre pressure when measured on a cold tyre. To measure the cold tyre pressure, the vehicle must have been stationary for 3 hours or driven only a few kilometres at a slow speed during this time.

 If the electronic stability program or anti-lock braking system is faulty, Tyre Pressure Loss Indicator will not work. → page 132

 After a warning about the tyre pressure being too low, switch the ignition off and then back on again. This is necessary before you can adapt the Tyre Pressure Loss Indicator again. <

Troubleshooting for Tyre Pressure Loss Indicator

 Please refer to  at the start of the chapter on page 183.

Low tyre pressure

The indicator lamp lights up yellow.

There is a loss of pressure in one or more tyres or the tyre is structurally damaged.

-  **Do not drive on!**
- Check and adjust the tyre pressures. → page 189
- Replace the damaged tyre.
- Re-synchronise the Tyre Pressure Loss Indicator → page 184.
- If the fault persists, go to a correspondingly qualified workshop. Volkswagen recommends using a Volkswagen dealership.

Fault in the Tyre Pressure Loss Indicator

The indicator lamp flashes for about 10 seconds and then remains lit continuously yellow.

There is a system fault.

-  **Do not drive on!**
- Switch the ignition off and on.

- Re-synchronise the Tyre Pressure Loss Indicator → page 184.
- If the fault persists, go to a correspondingly qualified workshop. Volkswagen recommends using a Volkswagen dealership.

WARNING

Different tyre pressure or too low tyre pressure may cause tyre failure, vehicle out of control, easy to cause casualties!

- Stop as soon as the light is  on and check the condition of all tyres. → page 186
- Different or low tyre pressure is bound to aggravate tyre wear, reduce vehicle stability, prolong the braking distance.
- Tyres with different or lower air pressure can suddenly malfunction, causing the tyre to burst and the vehicle to lose control.
- The driver must ensure that the correct air pressure is maintained on all tyres. The tyre pressure plate lists the prescribed tyre pressure. → page 189
- The tyre pressure monitoring system can function properly when all cold tyres maintain correct pressure.
- All tyre pressure must be properly adjusted for vehicle load. → page 189
- Make sure all tyres are charged to the correct air pressure before driving. → page 189
- If the tyre pressure is too low, it is possible that the tyre temperature will increase to such an extent when driving that the tread peels off and the tyre bursts.
- Excessive speeds and overloading of the vehicle can cause overheating and sudden tyre damage including tyre bursts.
- Whether the tyre pressure is too high or too low, the tyres will wear prematurely and the car will not handle well.
- If the tyre is not flat and it is not necessary to change the wheel immediately, drive at low speed to the nearest correspondingly qualified workshop and have the tyre pressure checked and corrected. → page 186
- Always adapt the Tyre Pressure Loss Indicator correctly.

 Driving on unpaved roads for long periods or a sporty driving style can temporarily deactivate the Tyre Pressure Loss Indicator. In the ▶

event of a malfunction, the indicator lamp will flash. However, the indicator lamp will go out when the road conditions or driving style change. ◀

Wheels and Tyres

Introduction

This chapter contains information on the following subjects:

– Using of Wheels and Tyres	187
– Wheel rims and wheel bolts	189
– Tyre pressure	189
– Tread depth and Tyre wear	191
– Tyre damage	191
– Wheel unbalance degree	192
– Tyre identification number	193
– Winter tyres	196
– Snow chains	196

The tyres are the most heavily loaded and most underestimated parts of a vehicle. Tyres are very important! As the narrow tyre surfaces are the only contact between the vehicle and the road.

The service life of tyres is dependent on tyre pressure, driving style, handling and correct fitting.

WARNING

New tyres or tyres which are old, worn down or damaged cannot provide full levels of vehicle control and braking efficiency.

- Incorrect handling of wheels and tyres can reduce vehicle safety and cause serious accidents and fatal injuries.
- All four wheels must be fitted with radial tyres of the same type, size (rolling circumference) and the same tread pattern.
- New tyres as the tyres have to be run in. Because its grip is unlikely to reach the best state, thus reducing the braking effect, it is necessary to drive carefully for the first 600 km to avoid causing serious accidents.
- Check the tyre pressure regularly and always maintain the specified pressure. If the tyre pressure is too low, it is possible that the

tyre temperature will increase to such an extent when driving that the tread peels off and the tyre bursts.

- Check the tyres regularly for damage and wear.
- Never drive with worn tyres or tyres that shows signs of damage due to holes, cuts, cracks or blisters. This can cause serious accidents and fatal injuries. Replace worn or damaged tyres immediately.
- Never exceed the top speed and load permitted for the fitted tyres.
- The efficiency of intelligent driver assistance systems and brake assistance systems depends on the road adhesion of tyres.
- If you notice unusual vibration, or if the vehicle pulls to one side when driving, stop immediately and check the wheels and tyres for damage.
- To reduce the risk of serious injury or death due to loss of control of the vehicle, never loosen the bolts on wheel rims with bolted-on rim rings.
- Do not use wheels or tyres if you do not know their history! Used wheels and tyres could be damaged, even if the damage is not visible.
- Old tyres (even if the tyres have never been used) can suddenly lose air or burst, particularly at high speeds. This can cause serious accidents and fatal injuries. Use tyres that are more than six years old only if you have no alternative. In this case, drive with extra care at all times at a low speed.

WARNING

Incorrectly tightened or missing wheel bolts can lead to loss of control over the vehicle, serious accidents and fatal injuries.

- Never drive if wheel bolts are missing or loose.
- Always use wheel bolts that match the wheel rims and the vehicle type.
- Always tighten the wheel bolts with the correct tightening torque. If you do not have a torque wrench available, tighten the wheel bolts with the wheel bolt wrench and have the torque checked immediately by the nearest suitably qualified workshop. Volkswagen recommends using a Volkswagen dealership. ▶

⚠ WARNING

If the tyre is not fitted correctly on the wheel rim, this can lead to damage to the wheel rim and the tyre could suddenly lose air or burst while driving. This can cause serious accidents and fatal injuries.

- Have tyres fitted on the wheel rims only by a correspondingly qualified workshop. Volkswagen recommends using a Volkswagen dealership.

Using of Wheels and Tyres

📖 Please refer to ⚠ at the start of the chapter on page 186.

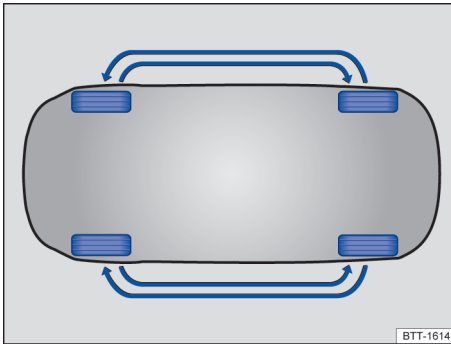

Fig. 146 Illustration: diagram showing how to swap wheels

Volkswagen-approved tyres and rims are guaranteed to have the dimensions that are suitable for the vehicle.

Swap wheels from the front to the rear

Regularly rotating the wheels as shown in the illustration is recommended to help ensure that tyres wear evenly. → Fig. 146 All the tyres will then last for about the same time.

Volkswagen recommends having a wheel change carried out by a correspondingly qualified workshop. Volkswagen recommends using a Volkswagen dealership.

Tyres and rim failure precautions

- Drive over kerbs and other low obstacles slowly and at right angles so that the two front wheels come into contact with the obstacle at the same time.
- Check the tyre pressure regularly.
- Check the tyres for damage such as cuts at regular intervals.
- Never exceed the maximum speed and load permitted for the tyres that are fitted. → page 193
- Have qualified workshop replace damaged or worn tyres as soon as possible. → page 191
- Protect the tyres from contact with aggressive substances, including grease, oil, petrol and brake fluid → ⚠.
- Replace missing dust caps on the valves immediately.
- Remove foreign bodies that have not yet penetrated to the inside of the tyre. → page 191
- Observe all warnings of the tyre monitoring system. → page 185

Tyres that are more than six years old

Tyres age through physical and chemical processes that can impair their function. Tyres that have been stored unused for an extended period of time age more quickly than tyres that are used all the time.

Volkswagen recommends replacing tyres that are more than six years old with new tyres. This also applies to tyres which appear to still be in good condition and whose tread depth has not yet reached the minimum value stipulated by legislation → ⚠.

Winter and all-season tyres also largely **lose their effectiveness** through ageing – regardless of the remaining tread depth.



The age of each tyre can be determined on the basis of the manufacturing date. → page 193

Notes on storing tyres

Before removing the tyre, mark the tyre to indicate the direction of rotation and installation position. When installing the tyre, it should be reset according to the mark (left, right, front, rear), so that the direction of rotation and dynamic balance of the wheel remain unchanged. ▶

- Always store tyres in a cool, dry and preferably dark place. Do not place **tyres** vertically.
- Any tyres not fitted on rims should be kept in suitable sleeves to protect against dirt and should be stored vertically (standing on the tread).

New tyres

- New tyres as the tyres have to be *run in*. Drive particularly carefully for the first 600 km, because its grip is unlikely to reach the best state, →  the braking efficiency is reduced → .
- All four wheels must be fitted with radial tyres of the same type, size (rolling circumference) and the same tread pattern.

Volkswagen Genuine tyres

The vehicle may be fitted with Volkswagen Genuine tyres at the factory. When used correctly Volkswagen Genuine tyres meet the highest standards with respect to safety and vehicle handling.

Replacing tyres

- The vehicle may be fitted with optimised rolling resistance tyres at the factory. Only with these tyres can the indicated fuel consumption values be achieved. → page 92 When replacing a new tyre, radial tyres of the same type, size (rolling circumference) and the same tread pattern as original tyres should be fitted.
- Seek advice from a suitably qualified workshop before purchasing new reduced rolling resistance tyres. Volkswagen recommends using a Volkswagen dealership.
- Always replace tyres at least on an axle-by-axle basis → .
- Old tyres should only be replaced by tyres that have been approved by Volkswagen for the vehicle type.
- Never use tyres with an effective size that is larger than Volkswagen-approved tyres.

Re-synchronising the Tyre Pressure Loss Indicator

The Tyre Pressure Loss Indicator must be re-synchronised each time one or more wheels is changed. → page 183 This also applies if the wheels have been swapped, e.g. from the front to the rear.

WARNING

Corrosive liquids and other substances can cause visible and invisible damage to the tyres, which can cause the tyre to burst!

- Always keep chemicals, oils, lubricants, fuel, brake fluid and other corrosive substances away from the tyres.

WARNING

Old tyres, even if they can still be used, can suddenly leak or burst at higher speeds, resulting in accidents and serious injuries.

- Use tyres that are more than six years old only if you have no alternative and drive with extra care at all times.

WARNING

New tyres as the tyres have to be run in. Because its grip is unlikely to reach the best state, thus reducing the braking effect,

- it is necessary to drive carefully for the first 600 km to avoid causing serious accidents.

WARNING

Wheels must have the necessary clearance. If there is insufficient clearance, there may be frictional contact between the wheels and parts of the running gear, body and brake lines. This can cause failure of the brake system, detachment of the tyre tread or a burst tyre and can thus lead to serious accidents and fatal injuries.

- Use only tyres whose dimensions do not exceed the tyre dimensions of tyre makes approved by Volkswagen and that do not rub on any vehicle parts.

NOTICE

Avoid strong impacts and drive around obstacles if possible. Potholes, bumps and curb edges can severely squeeze and deform tyres, especially those with low flat ratios, leading to tyre damage and rim deformation or cracks.

NOTICE

Do not damage the valve when refitting on other tyres. Never drive without valve caps. This can damage the valve.

 Old tyres should be disposed of properly and as required by legislation. ▶

i If the spare tyre is not the same as the tyres that are mounted on the vehicle only use the spare tyre in the event of a breakdown for a short period of time and drive with extra care. Replace the temporary spare wheel with a normal wheel as soon as possible.

i Volkswagen-approved tyres are guaranteed to have the dimensions that are suitable for the vehicle. In the case of other tyres, the tyre seller must provide a certificate from the tyre manufacturer stating that the tyre is also suitable for the vehicle. Store the certificate in a safe place and keep it in the vehicle.

Wheel rims and wheel bolts

📖 Please refer to **⚠️** at the start of the chapter on page 186.

The structure of the wheel bolt must match the rim. If different types of rims are installed, wheel bolts of appropriate length and bolt head shape must be used to ensure that the wheel is firmly installed and the braking system works properly. → page 198

Generally, for technical reasons, wheels of other vehicles cannot be used, and wheels of other vehicles of the same model cannot be used.

The tightening torque of the wheel bolt must usually be checked with a functioning torque wrench.

Wheel bolt

Correct wheel bolts must be used and tightened to the specified tightening torque. → page 198

Wheel rim identification

In some countries, new wheel rims must contain information on certain properties. The following information may be provided on the wheel rim.

- Seal of conformity
- Rim size
- Name of manufacturer or brand name
- Date manufactured (month/year)
- Country of origin
- Production number
- Raw material batch number
- Product code

⚠️ WARNING

The use of unsuitable or damaged wheel rims can impair vehicle safety and cause accidents and serious injury!

- Use only wheel rims that have been approved for the vehicle.
- Check the wheel rims regularly for damage and replace them if necessary.

Tyre pressure

📖 Please refer to **⚠️** at the start of the chapter on page 186.

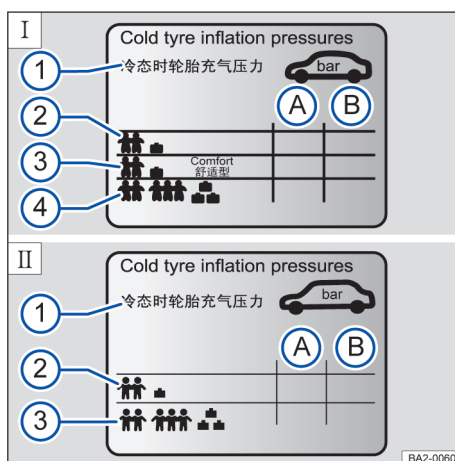

Fig. 147 Symbols on the tyre pressure sticker

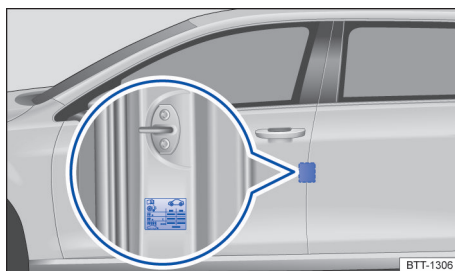

Fig. 148 On the driver door pillar: tyre pressure sticker

Data on the sticker (type I) → Fig. 147:

- Ⓐ Tyre pressure for the tyres on the front axle.
- Ⓑ Tyre pressure for the tyres on the rear axle.

- ① *Note:* Check the tyre pressure when the tyres are cold.
- ② Tyre pressure for partial load.
- ③ *Vehicle-dependent:* comfort tyre pressure for partial load.
- ④ Tyre pressure for full load.

Data on the sticker (type II) → Fig. 147:

- Ⓐ Tyre pressure for the tyres on the front axle.
- Ⓑ Tyre pressure for the tyres on the rear axle.
- ① *Note:* Check the tyre pressure when the tyres are cold.
- ② Tyre pressure for partial load.
- ③ Tyre pressure for full load.

The specified values of the original tyre pressure are marked on a sticker and the data listed on it are applicable in both winter and summer. The sticker is located below the inside of the driver door pillar. → Fig. 148

The appearance of the sticker may differ between vehicles.

An incorrect tyre pressure can adversely affect driving performance and cause tyre wear to accelerate and to burst. →  **When** driving tyre pressure is particularly important, tyre pressure does not meet the requirements will aggravate tyre wear, tyre easy to burst.

Comfort tyre pressure

Depending on the vehicle, the tyre pressure sticker may show details of a comfort tyre pressure → Fig. 147 ③. The comfort tyre pressure allows increased driving comfort. Fuel consumption may increase when driving with comfort tyre pressure.

Check tyre pressure

- Check tyre pressures regularly, at least once a month.
- Always check the tyre pressure when the tyres are cold. The specified tyre pressure applies to **cold tyres**. Tyre pressure is always higher in warm tyres than it is in cold tyres. For this reason, never reduce the pressure in warm tyres to adjust the tyre pressure.
- Tyre pressure should be adjusted according to the load condition ④.

- After adjusting the tyre pressures, always screw the caps onto the valves and observe the information on the tyre monitoring system.
- Always use the tyre pressure specified on the sticker. Never exceed the maximum tyre pressure which is given on the sidewall of the tyre.

WARNING

If the tyre pressure is too low or too high, this may cause the tyre to suddenly lose air or the tyre to burst while the vehicle is in motion! This can cause serious accidents and fatal injuries.

- If the tyre pressure is too low, it is possible that the tyre temperature will increase to such an extent when driving that the tread peels off and the tyre bursts.
- Excessive speeds and overloading of the vehicle can cause overheating, sudden tyre damage including tyre bursts and detachment of the tread.
- Whether the tyre pressure is too high or too low, the tyres will wear prematurely and the car will not handle well.
- Check tyre pressures regularly, at least once a month, and before every long journey.
- Always adapt the tyre pressure to the corresponding load level.
- Never reduce the increased tyre pressure of warm tyres.

NOTICE

- When attaching the tyre pressure gauge, ensure that you do not position it at an angle to the valve stem. Otherwise, the valve can be damaged if the tyre pressure gauge is not used with due care.
- Missing of the valve cap or improper fitting of the valve cap may damage the tyre valve, always use the same size valve cover as the original one and fit it correctly.



Underinflated tyres will result in increased fuel consumption. <

Tread depth and Tyre wear

📖 Please refer to ⚠️ at the start of the chapter on page 186.

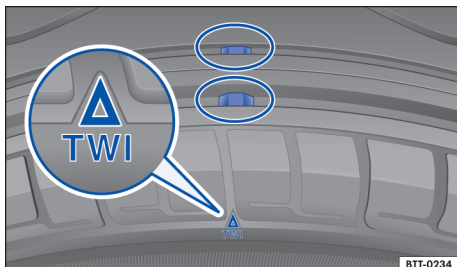

Fig. 149 Tyre tread: tread wear indicators (illustration)

Tread depth

Most driving situations require the highest possible tread depth. The tyres should have the same tread depth, at the minimum on each axle. This is especially true in wet or wintry road conditions.

In most countries, the minimum tread depth required by law is 1.6 mm, measured in the tread grooves next to the tread wear indicators. Observe any deviating country-specific legal regulations. The tyres should have the same tread depth, at the minimum on each axle. → ⚠️

Observe any country-specific legal requirements relating to the permissible minimum tread depths for winter and all-year tyres.

Tread wear depth indicators in tyres

The tread wear indicators show if a tyre is worn down. The tyre must be replaced at the latest when the tread depth is just down to the tread wear indicator.

There are 1.6 mm high wear indicators in the tread base of the tyres. → Fig. 149 Wear indicators are evenly distributed on the outer circumference of the tyre, and markings on the tyre sidewall indicate the position of the tread wear indicator, (e.g. "TWI" or other symbol) → Fig. 149.

⚠️ WARNING

Worn tyres can lead to loss of control over the vehicle, serious accidents and fatal injuries!

- Replace the tyres with new tyres at the latest when the tyres are worn down to the tread wear indicators.

- Worn tyres are easily to slippage (floating) when driving on wet roads.
- Worn tyres are a safety risk and make it difficult to control the vehicle well. They also increase the braking distance and the risk of skidding.

Tyre damage

📖 Please refer to ⚠️ at the start of the chapter on page 186.

Damage to tyres and rims is often not easily detected. If you notice **unusual vibration**, or if the **vehicle pulls to one side when driving**, indicates that a tyre is damaged → ⚠️.

- If you suspect that a wheel is damaged, slow down immediately!
- Check the tyres and rims for damage.
- Do not drive on if a tyre is damaged.
- Changing a damaged wheel → page 198. Seek expert assistance if necessary.
- If there is no visible damage, drive slowly and cautiously to the next correspondingly qualified workshop in order to have the vehicle checked. Volkswagen recommends using a Volkswagen dealership.

Foreign body embedded in the tyre

- Leave the foreign body in the tyre if it has entered the inner tyre! But foreign bodies that are stuck between the tyre tread blocks can be removed.
- Changing a damaged wheel → page 198. Seek expert assistance if necessary.
- Check and adjust the tyre pressures.
- Go to a correspondingly qualified workshop. Volkswagen recommends using a Volkswagen dealership.

Tyre wear

The tyre wear is affected by several factors:

- Style of driving.
- How well the tyres are balanced.
- Adjustments made to the running gear.

Fast cornering, heavy acceleration and hard braking all increase tyre wear. ▶

The wheels have been balanced when the vehicle leaves the factory, but there are many different factors that affect wheel balance in normal vehicle driving, resulting in wheel imbalance and steering oscillation. Unbalanced wheels will affect the level of tyre wear. In this case the wheels should be balanced again. Wheel balance must be carried out after replacement of new wheels.

Incorrect wheel alignment causes excessive tyre wear, impairing the safety of the vehicle. The wheel alignment should be checked by a suitably qualified workshop if tyres show excessive wear. Volkswagen recommends using a Volkswagen dealership.

WARNING

If you notice unusual vibration, or if the vehicle pulls to one side when driving, indicates that a tyre is damaged.

- Slow down your vehicle speed immediately and park your vehicle where it will not obstruct traffic.
- Check the tyres and rims for damage.
- If the tyre or rim is damaged, do not continue to drive, as soon as possible contact the qualified workshop.
- If there is no visible damage, drive slowly and cautiously to the next correspondingly qualified workshop in order to have the vehicle checked. Volkswagen recommends using a Volkswagen dealership.

Wheel unbalance degree

 Please refer to  at the start of the chapter on page 186.

If the wheel dynamic balance side more than 8 grams must be used to rebalance the wheel balance block.

Wheel balance must be carried out after replacement of wheels.

Cause of vehicle vibration while driving

There are many different factors that can cause a vehicle to run unsmoothly →  in *Tyre damage* on page 192.

Tyre wear is one of the causes of vibration when the vehicle is running. Tyre wear caused by driving is not evenly distributed on the surface of the whole pattern, which may make the original well-balanced tyre produce a mild imbalance, resulting in the uneven running of the tyre.

The driver may not be aware of this actual mild tyre imbalance through the steering wheel, which further increases tyre wear and reduces tyre life.

It is recommended to balance the tyre at least twice during the life of the tyre in order to ensure safety and ensure smooth operation and uniform wear throughout the life of the tyre.

Radial runout and lateral runout of tyres

Tyre and wheel rim concentric deviation that may produce radial runout and lateral runout.

For technical reasons, the tyre and the rim cannot be perfectly concentric.

If the deviation of the relative position of the tyre and the rim is too large, it may cause the unbalance of the tyre to exceed the allowable value.

WARNING

If you notice unusual vibration, or if the vehicle pulls to one side when driving, indicates that a tyre is damaged.

- Slow down immediately and stop the vehicle as soon as it is safe to do so.
- Check the tyres and rims for damage.
- Never drive with damaged tyres or tyres. Do not drive on. Seek expert assistance!
- If damage cannot be identified from the exterior, drive slowly and cautiously to the next correspondingly qualified workshop in order to have the vehicle checked. Volkswagen recommends using a Volkswagen dealership.

Tyre identification number

📖 Please refer to ⚠️ at the start of the chapter on page 186.

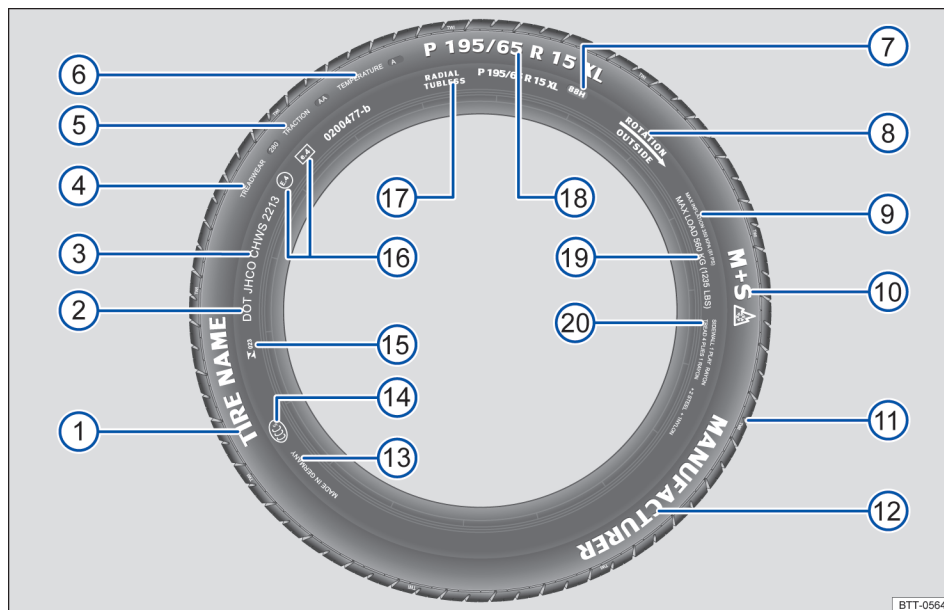





Fig. 150 International tyre lettering

→ Fig. 150	Tyre lettering (example)	Meaning	
①	Product name	Individual tyre designation of the manufacturer.	
②	DOT	The tyre complies with the legal requirements of the USA Department of Transportation, responsible for tyre safety standards.	
③	JHCO CHWS 2213	Tyre identification number TIN^{a)} - Possibly only on the inside of the wheel) and date of manufacture:	
		JHCO CHWS	Identifier of producing plant and specifications of the tyre manufacturer on size and characteristics.
		2213	Date of manufacture: 22nd week in 2013.
④	TREADWEAR 280	Relative life expectancy for the tyre, with reference to a US-specific standard test. Tyres with the specification 280 wear at a rate of 2.8 times more slowly than standard tyres that have a treadwear value of 100. The performance of tyres is determined by how they are used and can significantly deviate from standard values due to driving style, maintenance, road surface and climatic conditions. ▶	

→ Fig. 150	Tyre lettering (example)	Meaning	
⑤	TRACTION AA	Wet braking performance of the tyre (AA, A, B or C). The wet braking performance is tested under controlled conditions on certified test tracks. Tyres marked C have a low traction performance. The traction value assigned to the tyres is based on linear traction tests and does not include acceleration and lateral stability or aquaplaning and traction under maximum load.	
⑥	TEMPERATURE A	Temperature stability of the tyre at high speeds on a test bed (A, B or C). Tyres marked A and B tyres exceed legal requirements. The temperature evaluation is based on tyres with correct pressure and does not allow for excess pressure. Excessive speed, incorrect pressure or excess pressure can cause heat build-up or tyre damage. This applies to one or a combination of these factors.	
⑦	88 H	Load code → page 195 → page 195 Speed index.	
⑧	Rotation and arrow	Denotes direction of rotation. → page 195	
	Or: Outside	Denotes outside of tyres. → page 195	
⑨	MAX INFLATION 350 KPA (51 psi / 3.51 bar)	Limitation for the maximum air pressure.	
⑩	M+ <i>Sor</i> M/ <i>Sor</i> 	Denotes winter tyres (mud and snow tyres) → page 196. Studded snow tyres are labelled with an E after the S.	
⑪	TWI	Indicates the position of the tread wear indicator. → page 191	
⑫	<i>Brand name, logo</i>	Manufacturer.	
⑬	Made in Germany	Country of manufacture.	
⑭		Country-specific identification for China (China Compulsory Certification).	
⑮	 023	Country-specific identification for Brazil.	
⑯	E4 e4 0200477-b	Indicates conformity with international regulations. Approved tyres which comply with ECE regulations are identified with E. Tyres which comply with EG regulations are identified with E. This is followed by the multiple-digit approval number.	
⑰	RADIAL TUBELESS	Tubeless radial tyre.	
⑱	P 195 / 65 R 15 XL	Size designation:	
		P	indicates identification for passenger vehicle
		195	Tyre width (mm).
		65	Aspect ratio in (%).
		R	Tyre construction: radial.
		15	Rim diameter in inches.
XL	Heavy-duty tyres ("extra load tyres").		
⑲	MAX LOAD 615 KG (1235 LBS)	Load data for the maximum load per wheel. ▶	

→ Fig. 150	Tyre lettering (example)	Meaning
20	SIDEWALL 1 PLY RAYON	Details of the tyre carcass components: 1 ply of rayon (artificial silk).
	TREAD 4 PLYES 1 RAYON + 2 STEEL + 1 NYLON	Details of the tread components: In the example there are 4 plies under the tread surface: 1 ply of rayon (artificial silk), 2 steel belt plies and 1 nylon ply.

a) The TIN is the tyre serial number.

The tyre lettering can be located on the inner side of tyre. Certain labels may only be found on one side of the tyre, e.g. tyre identification number and manufacturing date.

Any further numbers and letters are internal codes used by the tyre manufacturer or country-specific codes.

Low-profile tyres

Low-profile tyres have a wider tread surface, larger rim diameter and lower side walls than conventional wheel/tyre combinations. → ① in *Using of Wheels and Tyres* on page 188. Low-profile tyres can improve the vehicle's handling and precision. They may however result in a less comfortable ride on uneven road surfaces and tracks.

Tyres with directional tread pattern

An arrow on the tyre sidewall indicates the direction of rotation on tyres with directional tread. Therefore, the tyres must be fitted in accordance with the marked rotation direction to ensure that the tyres have the best road adhesion, prevent the wheels from slipping, and reduce the rolling noise and wear rate of the tyres.

If, however, the tyre is fitted in the opposite direction to the tread pattern, you must take more care when driving, especially on slippery roads. The tyres must be replaced as quickly as possible or be fitted with the tread in the correct direction.

Asymmetrical tyres

Asymmetrical tyres take into account the differing behaviour of the inner and outer areas of the tread pattern. The sidewalls of asymmetrical tyres are marked to indicate "inside" or "outside", to ensure that the tyre has the best road adhesion, prevent the wheel from slipping and reduce the rolling noise and wear rate of the tyres.

Tyre load

The load index indicates the maximum load capacity of an individual tyre in kilograms (kg, tyre load).

Examples:

88	560 kg
91	615 kg
92	630 kg
93	650 kg
95	690 kg
97	730 kg
99	775 kg
100	800 kg
101	825 kg
102	850 kg
103	875 kg
104	900 kg
105	925 kg

Speed index.

The speed index indicates the maximum permitted speed that may be driven with the tyre.

P	Max. 150 km/h
Q	Max. 160 km/h
R	Max. 170 km/h
S	Max. 180 km/h
T	Max. 190 km/h
U	Max. 200 km/h
H	Max. 210 km/h
V	Max. 240 km/h
Z	above 240 km/h
W	Max. 270 km/h
Y	Max. 300 km/h

Some tyre manufacturers use the letter "ZR" to indicate a tyre with a maximum permissible speed above 240 km/h.

Winter tyres

📖 Please refer to ⚠️ at the start of the chapter on page 186.

Winter or all-season tyres improve the handling and braking characteristics in winter road conditions. Volkswagen recommends that winter tyres be fitted to the vehicle at temperatures below +7°C or in winter road conditions.

Tread pattern: Winter and all-season tyres lose their effectiveness when the tread is worn down to a depth of 4 mm.

The following applies when using winter tyres:

- Observe any country-specific legal requirements.
- Use winter tyres on all four wheels at the same time.
- Only use in winter road conditions.
- Only use the sizes of tyre that have been approved for the vehicle.
- Winter tyres must have the same belt type, size (rolling circumference) and the same tread pattern.
- Observe the maximum speed permitted by the speed rating → ⚠️.

Speed limitation

Winter tyres have a speed limit depending on the speed index. → page 193

Depending on the vehicle, the speed warning can be set using the instrument cluster. → page 13

V-rated winter tyres: The speed limits and required tyre pressure are determined by the engine size. You can get more information from the correspondingly qualified workshop. Volkswagen recommends using a Volkswagen dealership.

⚠️ WARNING

The improved handling due to winter tyres in winter conditions must not make you take safety risks.

- Exceeding the winter tyre speed limit can lead to loss of control over the vehicle and serious injuries.
- Adapt your speed and driving style to the current visibility, weather and road or traffic conditions.

- Never exceed the speed and load permitted for the fitted winter tyres.

🍃 The vehicle handling is better if summer tyres are fitted at temperatures above +7°C. The rolling noise is quieter, the tyre wear lower and the energy efficiency higher in this case

📖 In vehicles with a Tyre Pressure Loss Indicator, the system has to re-synchronise after changing to winter tyres. → page 183

📖 Ask a correspondingly qualified workshop about the permitted winter tyre sizes. Volkswagen recommends using a Volkswagen dealership. <

Snow chains

📖 Please refer to ⚠️ at the start of the chapter on page 186.

Please observe legislation and also the maximum permitted speed when driving your vehicle with snow chains.

On icy or snow-covered roads, snow chains will improve traction and braking response.

Snow chains: It may be fitted only to the front wheels. Also they may be fitted only to the following tyre and wheel rim combinations.

Tyre size	Wheel rim
215/60 R16	6J×16 ET43

Volkswagen recommends that you ask a correspondingly qualified workshop for information about appropriate wheel, tyre and snow chain sizes. Volkswagen recommends using a Volkswagen dealership.

Only fine-linked snow chains that add no more than around 15 mm (including tensioning device).

Remove hubcaps and trim rings before fitting snow chains → ⚠️. For safety reasons, cover caps must then be fitted over the wheel bolts. Caps are available from a correspondingly qualified workshop. Volkswagen recommends using a Volkswagen dealership. ▶

Temporary spare wheel

For technical reasons, snow chains must not be used on the temporary spare wheel or collapsible spare wheel. → page 200

In event of a flat tyre on one of the front wheels, fit the temporary spare wheel or collapsible spare wheel on the rear axle. Replace the damaged front wheel with the removed rear wheel. Observe the direction of rotation. Volkswagen recommends fitting the snow chains before fitting the wheel.

WARNING

The use of snow chains that are unsuitable for your vehicle or the incorrect installation of snow chains can cause serious accidents and fatal injuries!

- Always use the correct snow chains.
- Observe the fitting instructions of the snow chain manufacturer.
- When snow chains are fitted, never exceed the maximum speed specified by the snow chain manufacturer or the legally permitted maximum speed.

NOTICE

- Always remove the snow chains on road sections where there is no snow, otherwise they will adversely affect the vehicle handling and damage the tyres and will also be quickly destroyed.
- Snow chains that are in direct contact with the wheel rim can scratch or damage it. To avoid damage, use snow chains with integrated wheel rim protection.

 In vehicles with a Tyre Pressure Loss Indicator, the system must be re-synchronised when snow chains are fitted. → page 183

Wheel covers

Centre wheel trim



Fig. 151 Removing the centre wheel trim by pulling off

The centre wheel trim protects the wheel bolts and must be fitted again after changing the wheel.

Vehicles with the centre wheel trim

- *Removing:* Hold the back of the two edges and unplug the wheel centre trim until it comes loose from the rim. → Fig. 151
- *Place the cover on the fuse box:* Place the centre wheel trim centrally on the wheel rim and press against the wheel rim until you feel the trim engage in position.

WARNING

Using unsuitable hubcaps, or fitting them incorrectly, can cause accidents and serious injuries.

- Incorrectly fitted hubcaps can become loose while the vehicle is in motion and endanger other road users.
- Do not use damaged hubcaps.
- Incorrectly fitted hubcaps can interrupt or reduce the air supply for cooling the brakes. This also applies if hubcaps are retrofitted. If the airflow is not sufficient, the braking distance could increase significantly.

Wheel bolt caps



Fig. 152 Removing the wheel bolt caps (illustration)

The caps protect the wheel bolts and should be fitted fully back in position after changing the wheel.

Removing and fitting the caps

- *Removing:* Take the hook from the vehicle toolkit. → page 152
- Insert the hook through the opening in the cap, → Fig. 152 and then use the hook to pull off the cap in the direction of the arrow.
- *Place the cover on the fuse box:* Press the caps onto the bolts as far as they will go.

Self purchased and installed **anti-theft wheel bolt¹⁾** has a separate cap. It only fits onto the anti-theft wheel bolt and not onto the conventional wheel bolts. ◀

Changing a wheel

Introduction

This chapter contains information on the following subjects:

- | | |
|---|-----|
| – Preparations for changing wheels | 199 |
| – Wheel bolts | 199 |
| – Spare wheel and Temporary spare wheel | 200 |
| – Lifting the vehicle with the jack | 201 |
| – Changing a wheel | 203 |
| – After changing a wheel | 203 |

The jack supplied with the vehicle is only designed for changing a wheel when one vehicle tyre is damaged and has to be replaced. If both tyres on one side of the vehicle, both tyres on one axle, or all tyres are damaged, go to a suitably qualified workshop. Volkswagen recommends using a Volkswagen dealership.

You should carry out a wheel change yourself only when the vehicle is parked safely, you are familiar with the safety procedures and have access to the correct equipment. If the above conditions cannot be met, have the wheel change carried out by a suitably qualified workshop.

⚠ WARNING

Changing a wheel at the edge of the road can be dangerous! Therefore, in order to reduce the risk of injury or death, the following items must be observed when changing the wheel:

- Stop as soon as practicable and safe to do so. To be able to safely change the wheel, park the car at a safe distance from moving traffic.
- Move all vehicle occupants and particularly children so that they are at a safe distance from the work area and away from moving traffic.
- To warn other road users, switch on the hazard warning lights and set up the warning triangle.
- Jack up the vehicle only on a flat and firm surface, and use a large, strong board or similar support for the jack if necessary.
- Only when you are familiar with the replacement process can you replace the wheel by yourself. Seek expert assistance. Volkswagen recommends using a Volkswagen dealership.
- Always use suitable and undamaged tools to change the wheel.
- Before changing the wheel, switch off the engine and the electronic parking brake, and put the selector lever in position **P**. Or to reduce the risk of an unintended vehicle movement, engage a gear on vehicles with a manual gearbox.
- The wheel bolt tightening torque should be checked with a correctly functioning torque wrench immediately after changing a wheel. ▶

¹⁾ To be purchased by user.

- If your vehicle is equipped with a Tyre Pressure Loss Indicator, you must immediately adapt the system again after a wheel change. → page 184

- Always observe the items on the checklist and the generally valid safety precautions.

Preparations for changing wheels

📖 Please refer to ⚠ at the start of the chapter on page 198.

Checklist

The following actions must always be carried out in the given order in preparation for changing the wheel → ⚠:

1. If you find tyre loses air, park the vehicle at a safe distance from moving traffic as far as possible and park your vehicle on a flat, firm surface.
2. Switch on the electronic parking brake → page 122.
3. Automatic gearbox: move the selector lever to **P** → page 104.
4. Switch off the engine and remove the key from the ignition.
5. Manual gearbox: mounted into a gear.
6. Ensure that all occupants exit the vehicle and go to a safe place away from moving traffic.
7. Place the warning triangle in position to draw the attention of other road users to your vehicle, → page 49 and observe any legal requirements.
8. Chock the wheel diagonally opposite the wheel being worked on with a stone, collapsible chocks or another suitable object.
9. Remove any items of luggage from the luggage compartment
10. Remove the temporary spare wheels and the vehicle toolkit from the luggage compartment.
11. Depending on the vehicle, remove the wheel cover. → page 197

⚠ WARNING

Ignoring any of the items on this important safety checklist can lead to accidents and severe injuries.

Wheel bolts

📖 Please refer to ⚠ at the start of the chapter on page 198.

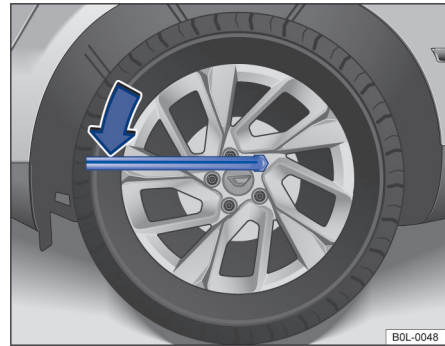

Fig. 153 Changing a wheel: loosening the wheel bolts

Use a suitable box spanner to loosen the wheel bolts.

Only loosen the wheel bolts by approximately one turn before raising the vehicle with the jack.

If one of the wheel bolts is very tight, you may be able to loosen it by pushing down the end of the box spanner carefully with your foot. Hold on to the vehicle for support and ensure that you have a secure footing.

Loosening the anti-theft wheel bolt

- Fit the box spanner over the wheel bolt as far as it will go. → Fig. 153
- Hold the end of the box spanner and turn the wheel bolt anticlockwise *for one* turn → ⚠.

Loosening the anti-theft wheel bolt¹⁾

If you buy and fit anti-theft wheel bolts

¹⁾ To be purchased by user.

- Insert the anti-theft wheel bolt adapter into the anti-theft wheel bolt as far as it will go.
- Push the box spanner onto the adapter as far as it will go.
- Hold the end of the box spanner and turn the wheel bolt anticlockwise *for one* turn → ⚠

An important note on wheel bolts

The structure of the rim and wheel bolts must match that of the original wheel. If other types of rims are installed, wheel bolts of appropriate length and bolt head shape must be used to ensure that the wheel is firmly installed and the braking system works properly.

Never use wheel bolts of other wheels, including those of other vehicles of the same type.

Tightening torque for wheel bolts

Specified tightening torque for wheel bolts for steel or alloy wheel rims: **140Nm**. After replacing the wheel, check the wheel bolt tightening torque at our qualified workshop immediately.

If the wheel bolts are corroded and stiff, **they must be renewed** and the wheel hub threads cleaned before the tightening torque is checked.

Never grease or oil the wheel bolts or the threads of the wheel hubs, otherwise the bolts may come loose while the vehicle is moving even if they are tightened to the specified tightening torque.

⚠ WARNING

Incorrectly tightened or missing wheel bolts can lead to loss of control over the vehicle, serious accidents and fatal injuries.

- Make sure that the wheel bolts and threads of the wheel hubs are clean, smooth running and free of oil and grease.
- Always use wheel bolts that match the wheel rims and the vehicle type.
- Only loosen the wheel bolts by approximately one turn before raising the vehicle with the jack.
- Never grease or oil the wheel bolts or the threads of the wheel hubs, otherwise the bolts may come loose while the vehicle is moving even if they are tightened to the specified tightening torque.
- Never loosen the bolts on wheel rims with bolted-on rim rings.

- If the tightening torque of the wheel bolts is too low, the wheel bolts and thus the wheel can become loose while the vehicle is in motion. The wheel bolts and the threads could be damaged if the tightening torque is too high.

⚠ WARNING

If the wrong wheel bolts are used, the wheel bolts can come loose while driving and lead to loss of control over the vehicle, serious accidents and fatal injuries.

- Always use wheel bolts that match the wheel rims and the vehicle type.
- Never use different wheel bolts.

Spare wheel and Temporary spare wheel

📖 Please refer to ⚠ at the start of the chapter on page 198.

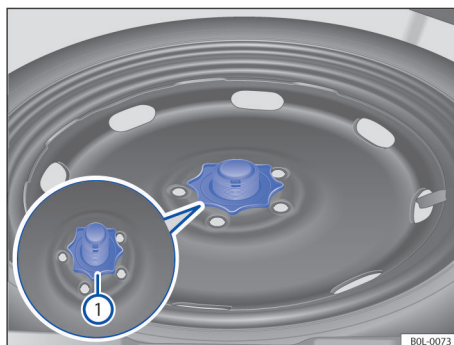

Fig. 154 In the luggage compartment: handwheel for securing the spare wheel or temporary spare wheel;

Take out temporary spare wheel

- Open the boot lid.
- Fold up or remove the luggage compartment floor. → page 145
- Fully unscrew the handwheel in the middle of the spare wheel or temporary spare wheel → Fig. 154 ① anticlockwise
- Take out temporary spare wheel.

Stowing the removed wheel

- Open the boot lid.
- Fold up or remove the luggage compartment floor. → page 145
- Place the removed wheel into the spare wheel well with the front of the rim facing downwards so that the centre hole in the rim is positioned exactly above the hole or threaded pin, then load the replacement wheel into the spare wheel well.
- Screw the handwheel clockwise onto the threaded pin until the replaced wheel is firmly secured.
- Return the vehicle toolkit to the container and stow the container in the luggage compartment. → page 145
- Close the boot lid.

If the spare wheel tyre differs from the other tyres on the vehicle

If the spare wheel tyre differs from the other tyres on the vehicle, the spare wheel must be used only in the event of a tyre failure and for a short time → .

Observe these driving guidelines:

- Do not drive faster than 80 km/h
- Avoid full acceleration, sudden braking and fast driving through bends in the road!
- Do not use snow chains on the temporary spare wheel. → page 196
- The tyre pressure must be checked as soon as possible after fitting the spare wheel or temporary spare wheel. → page 189

WARNING

Incorrect use of the spare wheel or temporary spare wheel can lead to a loss of control of the vehicle, serious accidents and fatal injuries!

- Do not use the spare wheel or temporary spare wheel under any circumstances if it is damaged or worn down to the tread wear indicators!
- The temporary spare wheel can be recognised by a sticker and the text "80 km/h" This is the maximum speed at which you are permitted to drive with this tyre.
- Never drive faster than 80 km/h! Do not accelerate quickly, brake suddenly or drive at high speed through bends.

- Never drive further than 200 km with a temporary spare wheel if it is fitted to the drive axle.
- Replace the temporary spare wheel with a normal wheel as soon as possible. The temporary spare wheel is designed for a short period of use only.
- Always secure the temporary spare wheel with the wheel bolts supplied from the factory.
- Never use more than one temporary spare wheel at a time.
- After fitting the spare wheel or temporary spare wheel, check the tyre pressure as quickly as possible. → page 189
- Do not use snow chains on the temporary spare wheel.

Lifting the vehicle with the jack



 Please refer to  at the start of the chapter on page 198.



Fig. 155 Jacking points

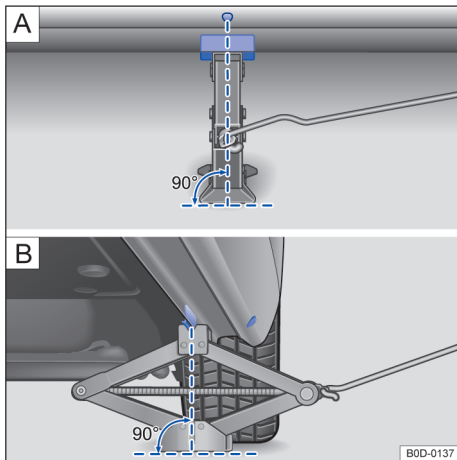

Fig. 156 Jack applied at the rear left-hand side of the vehicle

The jack may be positioned only at the reinforcements on the underbody, which are located behind the markings on the body. → Fig. 155 There are corresponding jacking points beside each wheel → ⚠.

Checklist

For your own safety, carry out the following points in the specified order → ⚠:

1. Find a flat and firm surface suitable for lifting vehicles.
2. Turn the steering wheel to keep the wheels straight.
3. Switch off the engine. If the vehicle with manual manual gearbox, move the selector lever into a gear; For automatic gearbox, put the gear lever in position P → page 104, switch on the electronic parking brake. → page 122
4. Chock the wheel diagonally opposite the wheel being worked on with collapsible wheel stop or other suitable object.
5. Loosen the wheel bolts of the wheel to be replaced. → page 199
6. Find the jacking point under the vehicle which is closest to the wheel that is being changed. → Fig. 155
7. Insert the hand crank into the opening on the jack. (depending on the vehicle type).
8. Crank up the jack until it just fits under the jacking point of the vehicle.

9. Make sure that the entire surface of the foot of the jack is resting securely on the ground and that the foot of the jack is positioned vertically directly beneath the jacking point → Fig. 156[A] and [B]
10. Position the jack and simultaneously continue to crank the claw up until it is in position around the jacking point underneath the vehicle. → Fig. 156
11. Crank the jack further until the wheel is just clear of the ground.

⚠ WARNING

Incorrect use of the vehicle jack can cause the vehicle to slip off the jack! This can lead to serious and fatal injuries! To reduce the risk of accident casualties, the following precautions must be strictly observed when lifting a vehicle:

- Use only vehicle jacks that have been approved by Volkswagen for your vehicle. Other vehicle jacks could slip out of position – this includes vehicle jacks supplied with other Volkswagen models.
- Jack up the vehicle only on a flat and firm surface. Soft ground or surfaces at an incline under the vehicle jack may cause the vehicle to slip off the jack. If necessary, use a large, strong board or similar support for the jack to prevent the jack from slipping.
- Use an anti-slip surface covering, e.g. a rubber mat, to prevent the jack from slipping on slippery ground, e.g. a tiled floor.
- Fit the jack only at the described jacking points. The jack claw must grip the vertical rib under the side member securely.
- Never place any part of your body, e.g. your arm, underneath the vehicle if the latter is only supported by the jack. Beware of injury!
- If you have to work underneath the vehicle, use suitable stands to provide extra support for the vehicle.
- Never lift the vehicle when the vehicle is tilted to one side or the engine is running.
- Never start the engine when the vehicle is jacked up! Engine vibrations can cause the vehicle to fall off the jack.

⚠ WARNING

Ignoring any of the items on this important safety checklist can lead to accidents and severe injuries! ▶

- Always observe the items on the checklist and the generally valid safety precautions to lift the vehicle.

Changing a wheel

📖 Please refer to ⚠️ at the start of the chapter on page 198.



Fig. 157 Wheel change: Unscrew the wheel bolts with the wheel wrench

Removing the wheel

- Observe the checklist carefully.→ page 199
- Loosening the wheel bolts→ page 199.
- Jack up the vehicle.→ page 201
- Using the wheel wrench, completely unscrew loosened wheel bolts→ Fig. 157 and place them on a clean surface.
- Remove the wheel.

Fitting the spare wheel

Note the tyre direction of rotation.→ page 193, *Tyre identification number*

- Put the wheel in place.
- If you buy and fit anti-theft wheel bolts,¹⁾ insert the anti-theft wheel bolt adapter into the anti-theft wheel bolt,¹⁾ Use the box spanner to tighten all the wheel bolts securely in a clockwise direction.
- Screw in wheel bolts in a clockwise direction, **and tighten them** slightly.
- Lower the vehicle with the jack.

¹⁾ Purchase it separately

- Use the box spanner to tighten all the wheel bolts securely in a clockwise direction.→ ⚠️. Do not tighten the bolts in clockwise or anticlockwise sequence. Tighten them in diagonal sequence.
- Fit caps or wheel bolt caps, wheel cover, and centre wheel trim.→ page 197

⚠️ WARNING

Incorrectly tightened or missing wheel bolts can lead to loss of control over the vehicle, serious accidents and fatal injuries!

- Never grease or oil the wheel bolt and the threads in the wheel hubs. This could cause them to loosen while the vehicle is in motion, even if the required torque setting is used.

After changing a wheel

📖 Please refer to ⚠️ at the start of the chapter on page 198.

- Clean the tools and place them back in the foam rubber holder in the luggage compartment.→ page 152
- Stow the changed wheel securely in the luggage compartment.
- Have the tightening torque of the wheel bolts checked as soon as possible at the nearest qualified workshop.→ page 200
- The damaged tyre should be replaced as soon as possible.

i After changing a wheel, the indicator lamp for the tyre monitoring system may indicate a fault in the system.→ page 185

Vehicle care

Vehicle care

Notes on vehicle care

Regular and expert care helps to maintain your vehicle's condition.

The longer contamination or dirt is left on the surface of vehicle components, the more difficult it can become to clean and treat them. Extended exposure may mean that it is no longer possible to remove contamination or dirt.

Appropriate accessories are available from a suitably qualified workshop. Follow the application instructions on the packaging. Consult a suitably qualified workshop if you have any questions about care products or if components are not listed. Volkswagen recommends using a Volkswagen dealership.

WARNING

Improper care and cleaning of components can irreparably damage the safety features of the vehicles. This can lead to serious injuries in the event of an accident.

- Use cleaning agents only in accordance with the manufacturer's instructions.
- Always use approved or recommended cleaning products.
- Use cleaning agents that contain solvents have corrosive effects on vehicle parts materials.
- Protect your hands and arms against parts with sharp edges, e.g. when cleaning the insides of the wheel housings.

WARNING

irty, misted-up or iced-up windows reduce visibility and can prevent the safety features of the vehicle from functioning properly.

- Drive only when you have a clear view through all windows.
- Do not treat the windscreen with water-repellent window coating agents. In unfavourable conditions, they can cause increased dazzle, which is dangerous!

WARNING

Care products may be toxic, highly flammable and hazardous. Improper use of care products or the use of unsuitable care products can cause burns and poisoning and can lead to accidents and serious or fatal injuries.

- Store care products only in the closed original container.
- Observe the instructions supplied with the product.
- Keep children away from all care products.
- May produce toxic vapours when used. Therefore, use care products only outside or in well-ventilated rooms.
- Never use turpentine, engine oil, fuel, nail varnish remover or other volatile fluids for vehicle care.

NOTICE

Contamination with aggressive and solvent-based ingredients can cause irreparable damage to the vehicle equipment, e.g. even if left for only a short time on seat covers or trim parts.

- Remove stains, dirt, and other fouling as soon as possible. Do not let contamination or dirt dry.
- Have stubborn stains removed by a suitably qualified workshop. <

Washing the vehicle

The longer materials such as insects, bird droppings, resins, road dust, industrial dust, tar, soot, anti-slip salt and other corrosive materials remain on the surface, the greater the damage to the body paint. High temperatures (e.g., sun exposure) further aggravate the corrosion effect. May only **bottom** need to be cleaned regularly.

Automatic car washes

Please observe information of the car wash operator, especially where add-on parts.→ .

- Preferably use car washes without brushes.
- Spray wash the vehicle with water before cleaning it.
- In the automatic car washer, the steering column shall not be locked.→ page 108 ▶

- The electronic parking brake, → page 123
windscreen wipers → page 78 and rain sensor
must be switched off before cleaning.
- Lock the boot lid.
- The exterior mirrors must be folded away.
- Close all doors, Windows and glass roof.
- Do not select cleaning programmes with hot
wax for vehicles with decorative and protec-
tive films.
- Regularly have the bottom of the vehicle thor-
oughly cleaned to remove residue.

High-pressure cleaner

- Never use rotary nozzles. → ⓘ Observe the
manufacturer's instructions.
- Use water up to a maximum temperature of
+60 °C only.
- Move the jet of water uniformly so that the
nozzle is at least 50 cm away from all the vehi-
cle components.
- Do not point the water jet at the same location
for too long. Tough stains should be pre-soft-
ened.
- Aim the water jet indirectly at sensitive vehicle
components if possible, e.g. rubber seals, side
windows, gloss strips, tyres, sensors, camera
lenses, decorative, protective film, rubber hos-
es, and insulation or door locks.
- Never clean windows that are iced up or cov-
ered in snow with a high-pressure cleaner.

Hand wash

Hand wash is often a protective way to clean a
vehicle. The following precautions must be ob-
served → ⓘ.

- Before washing the car, soften the dirt with
plenty of water, then rinse carefully.
- Clean with a soft sponge, a wash mitt or a
brush applying only light pressure. Start with
the roof and work from the top to the bottom.
- Clean sponges, gloves, or brushes thoroughly
at short intervals.
- Finally, clean wheels, doorsills and similar
parts. Use another sponge for this purpose.

Use a cleaning shampoo only for very stubborn
dirt.

Waxing

Regular waxing helps protect the body finish. *After washing*, when there is no obvious **water drop on the body surface of the vehicle** high quality hard wax curing agent can be applied.

Even if a preservative wax is used regularly in the car wash, Volkswagen recommends protecting the paint with suitable hard wax or with Volkswagen Genuine hard wax at least twice a year.

Polishing

The paint needs to be polished when the finish becomes dark and cannot be restored even after waxing.

Parts sprayed with matte paint shall not be polished to prevent them from shining → ⓘ.

Cleaning matte painted vehicles

Clean matte paint vehicles by hand or fabric cleaning device, and **do not** use preservative wax. When cleaning by hand, clean the vehicle with plenty of water to remove dust and coarse soiling, and then clean the surface with a neutral cleaning shampoo.¹⁾

In the case of matt paint, remove insects, grease stains and fingerprints with a special cleaner for matt paints.

⚠ WARNING

After a car wash, the braking action may be delayed as the brake discs and brake pads will be wet, or iced up in winter. The braking distance will increase as a result.

- Carry out careful braking manoeuvres several times to "dry and de-ice the brakes". Do not endanger other road users when performing braking manoeuvres and do not ignore any legal requirements.

ⓘ NOTICE

Improper vehicle cleaning can cause severe damage to the vehicle!

- Always observe the described tasks for vehicle care and cleaning.
- Do not wash the vehicle in direct sunlight.
- Never aim a water jet directly at doors or the boot lid in cold weather. Otherwise the lock and seal may freeze!

¹⁾ Neutral soap solution: Add up to two tablespoons of neutral soap diluted in one litre of water.

- The vehicle shall not be polished when the vehicle is dirty or in a dusty environment.

NOTICE

Vehicle washer that mechanically detect the outline of the vehicle may damage the vehicle, such as spoilers.

NOTICE

Improper car washing can damage parts spraying matt paint, plastic parts, headlamp glass and tail-light.

- Do not use a scraping brush with strong bristles.
- Matte paint vehicles can only be cleaned in the fabric brush washing device.
- Do not handle matt surfaces with hot wax.
- Never polish matt-painted surfaces.

 Wash the vehicle in dedicated cleaning areas only. This prevents any waste water contaminated by oil from entering the sewage system.

Caring for and cleaning the vehicle exterior

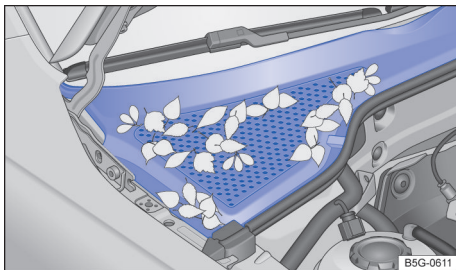

Fig. 158 Between the engine compartment and the windshield: drainage channel (illustration)

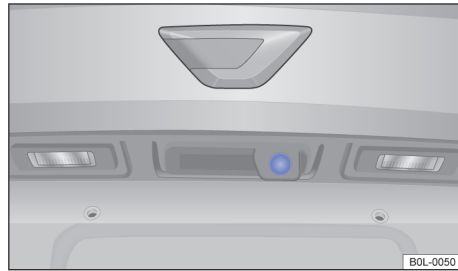



Fig. 159 At the rear of the vehicle: rear view camera (illustration)

The following overview contains recommendations for cleaning and care of individual vehicle components → .

Windows, glass surfaces:

Remove wax residue, e.g. from care products, using a suitable glass cleaner or with the Volkswagen Genuine cleaning cloth.

Remove snow with a hand brush. It is recommended to use the thaw ice with a suitable de-icer or with Volkswagen Genuine de-icer and remove ice with a plastic scraper. Move the scraper in one direction only.

Wiper blades: → page 153.

Paint:

Always treat surfaces with care so as not to remove the paint. Use a clean, soft cloth and a mild soap solution¹⁾ or cleaning clay to remove any light dirt immediately, e.g. deposits, insect residue, or cosmetics.

Only use touch-up pen to repair slightly damaged paint. In the event of matt paint damage, go to a correspondingly qualified workshop and have the paint damage repaired. Volkswagen recommends using a Volkswagen dealership.

Note:

- Overflowing fuel or service fluids: remove it with clean water immediately.
- Rust film: Remove sediment with rust film scavenger. Do not remove sediment by polishing! Then paint the vehicle with hard wax. If the fault persists, go to a correspondingly qualified workshop. Volkswagen recommends using a Volkswagen dealership.

¹⁾ Neutral soap solution: Add up to two tablespoons of neutral soap diluted in one litre of water.

- Rust: Should be handled by qualified workshop.
- When water no longer clearly forms small drops: apply the hard wax at least twice a year.
- The wax/paint lost its shine: clean the dirt and dust of the vehicle with appropriate polish product. If the polish does not contain wax material, apply the vehicle with hard wax.

Plenum chamber, engine compartment:

Remove leaves and other loose objects with a vacuum cleaner or by hand → Fig. 158 → ①. Always have cleaning of the engine compartment performed by a suitably qualified workshop. Volkswagen recommends using a Volkswagen dealership → ⚠.

Water that has entered the plenum chamber via a manual process (e.g. from a high-pressure cleaner) can cause considerable damage to the vehicle.

Sensors, camera lenses:

Clean the area in front of the sensors or camera with a soft cloth and solvent-free cleaning agent. Pay attention to the installation position. → page 5

Clean sensitive surfaces on the light sensor and the camera window on the windscreen in the same way as **Windows and glass surfaces** (Depending on vehicle equipment).

Remove snow with a hand brush. Never use warm or hot water. Thaw ice with a suitable de-icer or with Volkswagen Genuine de-icer.

Decorative films, protective films:

Remove the dirt on **paint**. Use a suitable plastic cleaner or Volkswagen Genuine plastic cleaner for matt decorative films.

Treat the vehicle with liquid hard wax every three months after washing and removing dust. Only use clean, soft microfibre cloths to apply the wax. **Do not use hot wax**, even in car washes.

Note:

- Remove carefully using white spirits, and then rinse with warm water.

Trim parts, trim strips made of chrome, aluminium or stainless steel:

Clean with soft cloth and mild soap solution¹⁾ in a dust-free environment.

If the chrome-plated strip is badly soiled, use a solvent-free cleaning agent if necessary.

Anodised surfaces: Do not use chrome care product.

Highlight plastic parts:

Remove soiling using a soft sponge soaked with a mild soap solution. Do not use any cleaning agents that contain alcohol or solvents.

Headlights, tail light clusters:

Remove soiling using a soft sponge soaked with a mild soap solution.¹⁾ Do not use any cleaning agents that contain alcohol or solvents.

Wheels:

Remove dirt and gritting salt deposits with plenty of water. Do not use vehicle paint polish or other abrasive agents.

For light metal wheels: Wash once every two weeks and then treat with an acid-free cleaner. Volkswagen recommends treating the wheel rims with a suitable hard wax or with Volkswagen Genuine hard wax every three months.

Note:

- Damaged protective paint: Repair the paint immediately with a touch-up pen. Go to a correspondingly qualified workshop if necessary.
- Brake dust: Use special cleaner.

Door lock cylinders:

It is suggested that the original factory spray with lubrication and rust prevention should be used when defrosting the door lock cylinders. Do not use door lock de-icer containing degreasing substances.

WARNING

Exercise extreme caution when working in the engine compartment! Pay attention to prevent being scratched, scald, cause accident and fire!

- Familiarize yourself with the necessary operations and general safety precautions before operation. → page 165
- It is recommended that qualified workshop perform these operations.

¹⁾ Neutral soap solution: Add up to two tablespoons of neutral soap diluted in one litre of water.

NOTICE

Improper cleaning and care may damage the vehicle.

- Always observe the described tasks for vehicle care and cleaning.
- Do not use hard cleaning materials that scratch.

NOTICE

The drainage channels for the plenum chamber may become blocked by leaves and dirt. Water that does not drain away can enter the vehicle interior and cause damage. Water that has entered the plenum chamber via a manual process (e.g. from a high-pressure cleaner) can cause considerable damage to the vehicle.

- Remove leaves and other loose objects with a vacuum cleaner or by hand from the cover of drainage channels.
- The area under the drain cover is cleaned by qualified workshop. Volkswagen recommends using a Volkswagen dealership.

 The durability and colour of decorative and protective films may be affected by environmental influences, such as sunlight, moisture, polluted air, stone impacts, etc. Signs of use and ageing are normal wear and tear and do not indicate any defects. Decorative films may show signs of wear and ageing after around one to three years, and protective films after two to three years. In very hot climates, decorative films may become faded within one year. The protective film is more durable and may become faded within two years.

Cleaning and care of the vehicle interior

The following overview contains recommendations for cleaning and care of individual vehicle components →  in *Caring for and cleaning the vehicle exterior* on page 208.

Windows:

Clean windows with a glass cleaner, and then wipe the windows dry with a clean chamois leather or a lint-free cloth.

Textiles, microfibre cloth and leatherette:

Remove dirt with a suitable interior cleaner or with Volkswagen Genuine interior cleaner. Never use leather care agents, solvents, wax polish, shoe cream, stain removers or similar.

Note:

- Never use high-pressure cleaners, steam cleaners and coolant spray.
- Dirt particles adhering to surfaces: Regularly remove them with a vacuum cleaner so that the material is not permanently damaged by abrasion.
- In the case of grease-based soiling such as oil, cosmetics: use a suitable interior cleaner or Volkswagen Genuine interior cleaner. Dab off dissolved grease and colour particles with an absorbent cloth. Then treat with water if necessary.
- In the case of soiling caused by ballpoint pens or nail varnish, latex paint, shoe polish, blood stains, for example, use a suitable interior cleaner or Volkswagen Genuine interior cleaner. If necessary, treat subsequently with a neutral soap solution.¹⁾

Natural leather:

Remove fresh contamination using a cotton cloth with a mild soap solution¹⁾. Do not allow fluids to seep into the seams.

Treat dried-in stains with a suitable leather cleaner or Volkswagen Genuine leather cleaner.

Apply a curing oil with anti-light and impregnation effect regularly and after each cleaning, and use a special coloured leather nourishing cream if necessary. If the vehicle is parked outdoors for long periods, you should cover the leather to protect it from direct sunlight.

Never treat leather with solvents, wax polish, shoe cream, stain removers or similar.

Note:

- For grease-based soiling such as oil, remove fresh stains with an absorbent cloth.
- In the case of soiling caused by ballpoint pens or nail varnish, and dried-in stains, use a suitable leather cleaner or Volkswagen Genuine leather cleaner.

Plastic parts:

¹⁾ Neutral soap solution: Add up to two tablespoons of neutral soap diluted in one litre of water.

Clean with a soft, moist cloth.

If stubborn soiling cannot be removed with mild soap solution, ¹⁾use a solvent-free plastic cleaning agent or Volkswagen Genuine plastic cleaner if necessary.

Trim parts, trim strips made of chrome, aluminium or stainless steel:

Clean with soft cloth and mild soap solution¹⁾ in a dust-free environment.

Anodised surfaces: Do not use chrome care product.

Control elements:

Remove coarse dirt and other dirt that is difficult to reach using a soft brush. Use a clean, soft cloth with some mild soap solution¹⁾ to clean control elements. Do not allow liquids to enter the controls.

Displays and screens:

Use a suitable cleaning cloth or Volkswagen Genuine cleaning cloth with a little water, a suitable glass cleaner or LCD cleaner. Do not clean the instrument cluster display and Infotainment system screen with a dry cloth. Switch off the Infotainment system temporarily before cleaning.

Rubber seals:

Clean with a soft and lint-free cloth as well as plenty of water.

Regularly treat with a suitable rubber care product or the Volkswagen Genuine rubber care product.

Seat belt:

Carefully pull the seat belt right out and leave it out. → . Remove coarse dirt with a soft brush. Use *mild* soap solution to clean the seat belts. Leave the belt fabric to dry completely and then allow it to roll up.

Wooden trims:

Clean with a soft cloth and some mild soap solution.¹⁾

Cleaning seat covers

For fabrics that fade easily, such as denim seat upholstery, fading will not affect the performance of the fabric. Parts of the airbag system and electrical connectors may be installed in the seat cover. Improper cleaning or soaking can damage

these components or interfere with correct functioning of the components. This can in turn then also lead to damage to other parts of the vehicle's electrical system →  in *Notes on vehicle care* on page 204.

Seat cushions with seat heating have electrical components and connectors that may be damaged in the event of incorrect cleaning or treatment. → . This can also result in damage to other parts of the vehicle electrics.

For the above reasons, the following items must be observed when cleaning the seat covers:

- Never use high-pressure cleaners, steam cleaners and coolant spray.
- Never switch on the seat heating to dry the seats.
- Do not use washing paste or fine detergent solutions.
- Never soak seat covers.
- If in doubt, go to a correspondingly qualified workshop. Volkswagen recommends using a Volkswagen dealership.

WARNING

Improper cleaning of the seat belts, their anchorages and the belt retractors can cause damage and prevent them from functioning properly.

- Never carry out any modifications on the seat belts for cleaning.
- Never clean the seat belts and their components with chemical agents.
- Do not use any caustic liquids, solvents or sharp objects.
- Protect the belt buckles against the ingress of liquids and foreign bodies.
- Let the cleaned seat belt to dry completely before allowing it to retract.

WARNING

Improper care and cleaning of components can irreparably damage the safety features of the vehicle, and prevent them from functioning properly. This can lead to serious injuries in the event of an accident.

- Vehicle parts must be cleaned according to the manufacturer's instructions. ▶

¹⁾ Neutral soap solution: Add up to two tablespoons of neutral soap diluted in one litre of water.

NOTICE

Improper cleaning and care may damage the vehicle.

- Always observe the described tasks for vehicle care and cleaning.
- Do not touch the seats with sharp-edged objects. Sharp objects, such as zips, rivets on clothing or belts, may damage surfaces.
- Do not use a steam cleaner, brushes or hard sponges etc.
- Have stubborn stains removed by a qualified workshop, so as not to damage the vehicle.

Accessories, modifications, repairs and renewal of parts

Accessories and replacement parts

Seek advice from a suitably qualified workshop before purchasing accessories, replacement parts or service fluids. If the vehicle is to be retrofitted with accessories or if parts have to be renewed, qualified workshops can provide information on legal requirements and also recommend accessories, replacement parts and service fluids. Volkswagen recommends using a Volkswagen dealership.

Volkswagen recommends using **Volkswagen Genuine Parts** and **Volkswagen Genuine Parts**[®]. These parts and accessories have been specially tested by Volkswagen for suitability, reliability and safety. A suitably qualified workshop also has the specialist skills for correct installation. Volkswagen recommends using a Volkswagen dealership.

Although the market is constantly scrutinised, **Volkswagen cannot assume responsibility for the reliability, safety and suitability of products** Volkswagen has not approved. Therefore, even if they have been approved by an official testing agency or are covered by an official approval certificate, Volkswagen can therefore assume no responsibility for these parts!

Any **retrofitted** equipment has a direct impact on the vehicle, it shall be confirmed by the Volkswagen whether it is suitable for the vehicle. These devices include cruise control systems or electronically controlled damping systems.

If auxiliary electrical equipment not related to the handling of the vehicle is added, **this equipment** must comply with the relevant national laws and regulations and meet the relevant technical requirements of the vehicle. Such devices include refrigerator boxes, computers and ventilator fans.

WARNING

Improper maintenance or modification of a vehicle can impair the protection of the airbags and lead to a fatal accident!

- Never secure or position objects in the deployment zones of the airbags.
- Objects in the deployment zone of the airbags can be flung through the vehicle interior or if the airbags are triggered. This can cause severe or fatal injuries.

Repairs and technical modifications

Repairs and technical modifications must always be carried out according to Volkswagen specifications → ⚠.

Unauthorised modifications to the electronic components or software in the vehicle may cause faults. As the electronic components are linked together in networks, these faults may indirectly affect the working of other systems. This can seriously impair vehicle safety, lead to excessive wear of components and also invalidate the type approval for the vehicle.

The Volkswagen dealership is not responsible for damage caused by technical modifications and/or work performed incorrectly. Such damage is not covered by the Volkswagen guarantee.

Volkswagen recommends using a Volkswagen dealership that supplies **Volkswagen Genuine Parts**[®]. Go to a correspondingly qualified workshop. Volkswagen recommends using a Volkswagen dealership. ▶

Vehicles with special auxiliary equipment or body parts

Auxiliary equipment and manufacturers must ensure that the equipment and bodies adhere to the stipulated environmental laws and regulations.

The vehicle owner must keep all assembly documentation for these conversions and pass it on to the scrapping company upon vehicle handover if the vehicle is scrapped. This is intended to facilitate environmentally responsible disposal for all vehicles, including refitted vehicles (including the old car with accessories and parts).

Repair windscreen

Some systems must be equipped with sensors. If the windscreen has been damaged in the viewing field of the sensors and camera, e.g. by stone chips, the windscreen must be replaced. Repair of the stone chip damage can lead to malfunctions or functional faults in the driver assist systems.

After replacing the windscreen, the camera and sensors must be adjusted and calibrated by a suitably qualified workshop. Volkswagen recommends using a Volkswagen dealership.

Damage in the area of sensors and cameras

Incorrectly performed repairs, structural changes to the vehicle, e.g. "lowering the suspension", retrofitted add-on parts or changes to the trim can lead to sensors and cameras being displaced or damaged. If the area around sensor and cameras is damaged, e.g. by stone chips or impacts when parking,

this can prevent the driver assist systems from functioning correctly.

Do not cover the area in front of and around sensors and cameras with stickers, auxiliary headlights, license plate frames, or similar items.

Go to a correspondingly qualified workshop. Volkswagen recommends using a Volkswagen dealership.

Note:

- Repainting and supplementary painting in the sensor area may affect the function of the corresponding system.
- The radiator grille area can affect the radar sensor area of view, so only the original radiator grille can be used.

Engine and transmission guard

It is recommended to install engine and transmission guard according to the condition of the vehicle. An engine and transmission guard can reduce the risk of damage to the vehicle's underbody and sump, for example when driving over kerbs, drive entrances or unsurfaced roads. Have retrofitting carried out by a correspondingly qualified workshop. Volkswagen recommends using a Volkswagen dealership.

WARNING

Incorrect repairs and modifications to the vehicle can cause breakdowns, damage the vehicle, reduce the efficiency of the steering wheel and braking system. This can cause malfunctions and lead to accidents and serious or fatal injuries.

- Have repairs and modifications to your vehicle carried out only by a correspondingly qualified workshop. Volkswagen recommends using a Volkswagen dealership.

WARNING

Incorrectly performed repairs and modifications on the vehicle, e.g. through use of unsuitable parts, can damage the vehicle and cause accidents and serious or fatal injuries!

- Volkswagen recommends the use of Volkswagen Genuine Parts or Volkswagen Genuine Accessories[®]. These parts and accessories have been specially tested by Volkswagen for suitability, reliability and safety.
- The maintenance and modification of the vehicles shall be carried out by the qualified workshop who have the necessary tools, diagnostic instruments, maintenance materials and qualified professional and technical personnel.
- The parts fitted must be exactly the same as the original parts.
- Never secure or position objects in the deployment zones of the airbags.
- Use only wheel rim/tyre combinations that have been approved by Volkswagen for your vehicle type.

Repairs and faults in the airbag system

Repairs and technical modifications must always be carried out according to Volkswagen specifications → ▲.

Modifications and repairs to the front bumper, the doors, the front seats, the roof or the bodywork should only be carried out by a suitably qualified workshop. Volkswagen recommends using a Volkswagen dealership. System components and airbag system sensors might be fitted on these vehicle components.

you work on the airbag system or remove and install parts of the system when performing other repair work, parts of the airbag system may be damaged. The consequence may be that, in the event of an accident, the airbag inflates incorrectly or does not inflate at all.

Regulations must be observed to ensure that the effectiveness of the airbags is not reduced and that removed parts do not cause any injuries or environmental pollution. These requirements are known to the correspondingly qualified workshops. Volkswagen recommends using a Volkswagen dealership.

Any modifications to the vehicle's suspension could prevent the airbag system from working properly during a collision. For example, using wheel rim/tyre combinations that have not been approved by Volkswagen, lowering the vehicle or making modifications to the suspension rate including work on the springs, struts and shock absorbers etc., could change the forces that are measured by the airbag sensors and sent to the electronic control unit. Some changes to the suspension could cause the forces measured by the sensors to increase, for example. This can lead to the airbag system being triggered in collision scenarios where it normally would not be triggered if modifications to the suspension had not been made. Other modifications can cause the forces measured by the sensors to decrease, therefore preventing the airbag system from being triggered when it should have been.

▲ WARNING

Incorrect repairs and modifications to the vehicle can cause breakdowns, damage the vehicle, reduce the efficiency of the steering wheel and

braking system. This can cause malfunctions and lead to accidents and serious or fatal injuries!

- Have repairs and modifications to your vehicle carried out only by a correspondingly qualified workshop. Volkswagen recommends using a Volkswagen dealership.
- Please note that the airbag unit cannot be repaired, but must be replaced!
- Never install recycled airbag components or components that have been taken from end-of-life vehicles in your vehicle.

▲ WARNING

Modification of the vehicle suspension, including the use of non-approved wheel rim and tyre combinations, can change how the airbag functions. This can result in serious or fatal injuries in the event of an accident!

- Never install components in the suspension system which do not have the same characteristics as the original factory-fitted components.
- Never use wheel rim/tyre combinations that have not been approved by Volkswagen.

Mobile communication in the vehicle

Electromagnetic radiation

If a mobile telephone or radio device is used without being connected to the external aerial, the electromagnetic radiation will not be optimally directed to the outside of the vehicle. Increased levels of radiation in the vehicle interior may occur in areas with poor signal in particular, for instance in rural areas. This could constitute a health hazard → ▲.

Depending on the vehicle's equipment level, a suitable mobile phone interface can be used to connect the mobile telephone to the external aerial. → Booklet *Infotainment system* The connection quality is improved and the range is increased.

Using the telephone

Many countries require a hands-free system to be used when using a telephone inside the vehicle, e.g. via a Bluetooth[®] connection. Before use, secure the mobile telephone to a suitable

bracket, → ⚠ or stow it in a storage compartment so that it cannot slip around, e.g. in the centre console.

In case of support for **SIM card access mode (rSAP)** technology for telephone interfaces, use a compatible mobile phone. In case of support for **LTE** mobile communications standard, using a SIM card with LTE data option.

Two-way radios

Observe legal requirements and the manufacturer's operating instructions for operating two-way radios. The retrofitting of two-way radios requires authorisation.

Ask a qualified workshop for further information on installation of a two-way radio. Volkswagen recommends using a Volkswagen dealership.

⚠ WARNING

Mobile telephones that are not secured or not properly secured could be flung through the vehicle interior in the event of a sudden driving or braking manoeuvre or accident and cause serious injuries.

- Secure or stow a mobile telephone and accessories safely and outside the deployment zone of the airbags such as telephone cages, notepads, portable navigators and phone accessories.

⚠ WARNING

If a mobile telephone or two-way radio that is not connected to an external aerial is used, electromagnetic radiation in the vehicle could exceed limit values. This also applies to external aerials which have not been correctly installed. This can endanger the health of the driver and the vehicle occupants.

- Keep a distance of around 20 cm between a device's aerial and an active medical implant, e.g. a pacemaker.
- Do not carry device which is operationally ready close to or directly above an active medical implant, e.g. in a breast pocket.
- Switch off the device immediately if you suspect it may be interfering with an active medical implant or any other medical device.

Customer information

Information recorded in the control units

Your vehicle is fitted with electronic control units. In order to ensure the safe operation of the vehicle, some control units are needed to control. Some control units are required for the safe functioning of your vehicle, others support you when driving (driver assist systems). In addition, the vehicle also provides comfort and infotainment system, which are also realized through the electronic control unit.

Electronic control units are equipped with temporary or long-term storage of data on vehicle status, component load, maintenance requirements, as well as technical content and faults. Depending on the technical equipment, the following data is stored:

- Operating states of system components, e.g. filling levels, tyre pressure, status of the vehicle battery.
- Vehicle status information, e.g. speed, deceleration, lateral acceleration, number of wheel revolutions and display of closed seat belts.
- Faults or malfunctions in important system components, e.g. lights, brakes.
- Information on events which damaged the vehicle.
- System reactions to specific driving situations, e.g. triggering of an airbag, intervention of the stability control systems.
- Ambient conditions, e.g. temperature and rain.

In addition to the application of the control unit functions themselves, these data are also used by the company to identify and troubleshoot faults and optimize vehicle functions. Much of this data is temporary and applied only inside the vehicle. Only a small part of the data is kept in the failure memory and, if necessary, in the vehicle keys.

Read event data recorder

This vehicle is equipped with an event data recorder for reading the data stored in the event memory, → ⚠ event memory records fault data and data that deviates from the specified value of the control unit. Additional information on the ▶

stored data is available from suitably qualified workshops. Volkswagen recommends using a Volkswagen dealership.

The diagnostic interface is located in the footwell on the driver side underneath the dash panel.

The event memory should only be read and reset by a suitably qualified workshop.

After a fault has been rectified, the information in the event memory relating to the fault is deleted. Other memory content is overwritten on an ongoing basis.

Reprogramming control units

All data for the control of components is stored in the control units. Convenience functions such as lane change flashing, individual door opening and display mode can be reprogrammed with dedicated devices. If the convenience functions are reprogrammed, the specifications and descriptions in this owner's manual will no longer match the original functions. Therefore, Have the reprogramming entered into the digital service schedule by a suitably "qualified workshop". Volkswagen recommends using a Volkswagen dealership.

Suitably qualified workshops are informed about this type of reprogramming. Volkswagen recommends using a Volkswagen dealership.

Infotainment system

Depending on the equipment installed, you may be able to store your own data in the vehicle's Infotainment system. The data includes:

- Media files for playback of music, films or photos in an Infotainment system.
- Address book data for use with a hands-free system or navigation system.
- Navigation destinations entered.
- Data on the use of online services.

This data can be stored locally in the vehicle or located on a device that you have connected to the vehicle, e.g. mobile telephone, USB stick or MP3 player. If this data is stored in the vehicle, you can delete it at any time. This data is transmitted to third parties only at your request, in particular in relation to the use of online services and in accordance with your personal settings.

You can store convenience settings (personalisation) in the vehicle and change or reset them at any time. Depending on the equipment in the vehicle, this includes, for example:

- Settings of the seat position.
- Air conditioning settings.
- Personalised settings such as mirror adjustment.

Integration of mobile telephones

If your vehicle contains the necessary equipment, you can connect your mobile telephone or any other mobile end device to your vehicle so that you can control this device via the controls integrated in the vehicle when the corresponding functions are available. For example, images and sounds from the mobile telephone can be output through the Infotainment system. At the same time, certain information is sent to your mobile telephone. This includes location data and further general vehicle information, depending on the type of integration. For more details, refer to the information about display of apps in the Infotainment system.

This enables you to use selected mobile telephone apps in the vehicle, e.g. navigation or music player. The mobile telephone and vehicle do not interact in any other ways than those described here; in particular the device does not actively access vehicle data. The type of further data processing depends on the app provider. The settings that you can adjust here depend on the app you are using and the operating system on your mobile telephone.

WARNING

Improper use of the diagnostic interface may cause faults, which may cause accidents and injuries.

- Do not use the diagnostic interface to read the event memory.
- The event memory should only be read and reset by a suitably qualified workshop.

Personal data protection

Personal information processing notification statement

When you use the vehicle repair, replacement and return services provided by FaW-Volkswagen Automobile Co., LTD. (hereinafter referred to as "FAW-VW") and authorized dealers of FAW-VW (hereinafter referred to as "dealers"), for information statistics, claim management and fault cause analysis, The dealer will collect your vehicle chassis number (i.e. VIN code), license plate number, vehicle running data and fault information (see below for details) and share them with FAW-VW and third parties authorized by FAW-VW (including relevant dealers and suppliers. For dealer information, please check FAW-VW official website www.faw-vw.com and select dealer query item; Supplier information can call 4008-171-111 to consult human customer service).

FAW-VW and the Distributor shall retain your personal information only for the period required by laws and regulations and as long as is necessary to achieve the purpose stated above. It will be deleted or anonymised beyond the above retention period. If you need to inquire, change, delete your personal information, you can call 4008-171-111 through the human service for corresponding operations.

FAW-VW and its dealers will fulfil their duty of care with high prudence and take strict technical measures to prevent information leakage. If we terminate our services or operations, we will notify you at least 15 days in advance and delete or anonymise your personal information after the termination of our services or operations.

Vehicle identification number (i.e. VIN code), vehicle driving data and fault information

Vehicle identification number VIN

Each vehicle has a unique chassis number by which your vehicle can be identified and traced back to the current and previous owners of the vehicle. The data generated or processed by the controller may be personally relevant, or may be personally relevant under certain conditions. For example, your driving behaviour, location or your driving route and usage habits.

Vehicle operating data

An electronic control unit (ECU) is installed in your vehicle to process data and operate the vehicle. ECU process data received from vehicle sensors or generated by ECU themselves or exchanged between controllers. Some control units are necessary for the safe operation of your vehicle, some are there to support you while driving (such as a vehicle driver assistance system), and some are there for comfort driving or infotainment functions.

These include, for example:

- Vehicle status information, e.g. speed, deceleration, lateral acceleration, number of wheel revolutions and display of closed seat belts.
- Ambient conditions, e.g. temperature, rain, and distance.

As a rule, this data is volatile and is not stored beyond the operating time and is only processed in the vehicle itself.

Control units often contain data storage devices (including vehicle keys). These are used to document information regarding the vehicle status, component load levels, maintenance requirements, technical events and faults on a temporary or permanent basis.

Depending on the technical equipment, the following data is stored:

- Operating states of system components, e.g. filling levels, tyre pressure, status of the vehicle battery.
- Faults or malfunctions in important system components, e.g. lights, brakes
- System reactions to specific driving situations, e.g. triggering of an airbag, intervention of the stability control systems.
- Information on events which damaged the vehicle.
- The electric vehicle is in the state of charging the high voltage battery, and the remaining mileage is estimated.

In special cases, e.g. when the vehicle has detected a malfunction, it may be necessary to store data that would normally only be volatile.

Information on the convenience functions and infotainment system

You can store convenience settings (personalisation) in the vehicle and change or reset them at any time. ▶

Depending on the equipment in the vehicle, this includes, for example:

- Settings of the seat and steering wheel positions.
- Running gear and air conditioning settings.
- Personalised settings such as mirror adjustment or background lighting.

Depending on the equipment installed, you may be able to store your own data in the vehicle's Infotainment system.

Depending on the equipment in the vehicle, this includes, for example:

- Media files for playback of music, films or photos in an Infotainment system.
- Address book data for use with a hands-free system or navigation system.

Vehicle fault information

Based on user complaints, repairman will collect information reflecting complaints such as noise, service fluid leakage, warning lights, hardware defects and other information through photos, videos or recordings of varying duration to support the analysis of your complaint.

Notification on Outbound Data Transfer

In principle, personal information collected and generated by FaW-Volkswagen Automobile Co., LTD. (hereinafter referred to as "FAW-VW") and authorized dealers of FaW-VW (hereinafter referred to as "Dealers") within the territory of the People's Republic of China will be stored within the territory of the People's Republic of China.

However, as the Volkswagen brand provides products or services through resources and servers all over the world, it means that when Faw-VW and its dealers provide you with vehicle repair, replacement and return services, your personal information (VIN code, vehicle running data, vehicle fault information, etc.) shall be obtained after obtaining your authorized consent in order to check the claim form and inquire the vehicle maintenance information. See below) may be transmitted to or accessed from jurisdictions outside the People's Republic of China, including the European Union, Switzerland, the United Kingdom, Japan, Mexico, Malaysia, Turkey, and we will inform users of any changes in the scope

of such jurisdictions in the future by updating this Statement in a timely manner. At the same time, we will ensure that your personal information is adequately and equally protected within the People's Republic of China.

FAW-VW and the Distributor shall retain your personal information only for the period required by laws and regulations and as long as is necessary to achieve the purpose stated above. It will be deleted or anonymised beyond the above retention period. If you need to inquire, change, delete your personal information, you can call 4008-171-111 through the human service for corresponding operations.

FAW-VW and its dealers will fulfil their duty of care with high prudence and take strict technical measures to prevent information leakage. If we terminate our services or operations, we will notify you at least 15 days in advance and delete or anonymise your personal information after the termination of our services or operations.

Name of overseas recipient: Volkswagen Group Co., Ltd. and the import suppliers related to this service (for supplier information, please call the manual customer service at 4008-171-111)

Vehicle identification number (i.e. VIN code), vehicle driving data and fault information

Vehicle identification number VIN

Each vehicle has a unique chassis number by which your vehicle can be identified and traced back to the current and previous owners of the vehicle. The data generated or processed by the controller may be personally relevant, or may be personally relevant under certain conditions. For example, your driving behaviour, location or your driving route and usage habits.

Vehicle operating data

An electronic control unit (ECU) is installed in your vehicle to process data and operate the vehicle. ECU process data received from vehicle sensors or generated by ECU themselves or exchanged between controllers. Some control units are necessary for the safe operation of your vehicle, some are there to support you while driving (such as a vehicle driver assistance system), and some are there for comfort driving or infotainment functions.

These include, for example:

- Vehicle status information, e.g. speed, deceleration, lateral acceleration, number of wheel revolutions and display of closed seat belts.
- Ambient conditions, e.g. temperature, rain, and distance.

As a rule, this data is volatile and is not stored beyond the operating time and is only processed in the vehicle itself. Control units often contain data storage devices (including vehicle keys). These are used to document information regarding the vehicle status, component load levels, maintenance requirements, technical events and faults on a temporary or permanent basis.

Depending on the technical equipment, the following data is stored:

- Operating states of system components, e.g. filling levels, tyre pressure, status of the vehicle battery.
- Faults or malfunctions in important system components, e.g. lights, brakes
- System reactions to specific driving situations, e.g. triggering of an airbag, intervention of the stability control systems.
- Information on events which damaged the vehicle.
- The electric vehicle is in the state of charging the high voltage battery, and the remaining mileage is estimated.

In special cases, e.g. when the vehicle has detected a malfunction, it may be necessary to store data that would normally only be volatile.

Information on the convenience functions and infotainment system

You can store convenience settings (personalisation) in the vehicle and change or reset them at any time.

Depending on the equipment in the vehicle, this includes, for example:

- Settings of the seat and steering wheel positions.
- Running gear and air conditioning settings.
- Personalised settings such as mirror adjustment or background lighting.

Depending on the equipment installed, you may be able to store your own data in the vehicle's Infotainment system.

Depending on the equipment in the vehicle, this includes, for example:

- Media files for playback of music, films or photos in an Infotainment system.
- Address book data for use with a hands-free system or navigation system.

Vehicle fault information

Based on user complaints, repairman will collect information reflecting complaints such as noise, service fluid leakage, warning lights, hardware defects and other information through photos, videos or recordings of varying duration to support the analysis of your complaint. <

Event Data Recorder

This vehicle is equipped with an event data recorder.

The event data recorder's main job is to record data in accidents or situations similar to an accident, e.g. when an airbag is triggered or when the vehicle collides with an obstacle on the road, which then supports analysis of how a vehicle system behaved. The event data recorder is intended to record data relating to driving dynamics and the restraint system for a short period of 10 seconds or less. Such as:

- How various systems in your vehicle have functioned.
- Whether the driver and front passenger seat belts were fastened/secured.
- The extent to which the driver pressed the brake or accelerator pedal.
- How fast the vehicle was travelling.

This data helps to obtain a better understanding of the circumstances in the situations where accidents and injuries have occurred.

Data from driver assist systems is also recorded. In addition to information about whether the systems were switched on or off, available only to a restricted extent or inactive, it is also possible to determine whether these functions steered, accelerated or braked the vehicle in the above-described situations. Depending on the vehicle equipment, these systems include the following: >

- Adaptive cruise control
- Lane keeping system
- Emergency braking function

EDR data is recorded by your vehicle only if an unusual situation similar to an accident occurs. No data is recorded by the event data recorder under normal driving conditions. In addition, no personal data, e.g. name, gender, age or accident location, is recorded. However, third parties such as law enforcement agencies can use appropriate means to link the content of the event data recorder with other sources of data and thus establish a reference to persons as part of an accident investigation.

To read data from the event data recorder, switch on the ignition and use special equipment to access the vehicle or event data recorder through the authorized diagnostic interface (on-board diagnostics). For more information on obtaining the EDR data extraction tool, please call 4008-171-888.

Volkswagen will not access, read or process data from the event data recorder unless the vehicle keeper grants their permission.

Due to its legal product monitoring obligations, Volkswagen is entitled to use the data for field monitoring and also for research purposes and quality improvements. For research purposes, Volkswagen makes the data available to third parties in anonymous form, in other words without any reference to the individual vehicle or vehicle keeper.

EDR trigger and coverage mechanism

When the vehicle records “transverse delta-V”, the EDR is triggered when there is a vehicle speed change no less than 8 km/h within 150 ms in the X-axis direction or Y-axis direction. The event is locked when irreversible restraint deployment occurs.

If the EDR storage is insufficient, the current event data will overwrite previous non-locked event data in chronological order. Locked event data will not be covered by subsequent events.

Implementation methods of intelligent control system

1. Cruise control system (GRA)

For detailed information, refer to the driver assistance systems → page 110. The associated data element is the “cruise control status” in Class B, which may have the following status:

- Switched on and activated
- Switched on but deactivated
- Switched off
- Malfunction

2. Adaptive cruise control (ACC)

For detailed information, refer to the driver assistance systems → page 110. The associated data element is the “adaptive cruise control status” in Class B, which may have the following status:

- Switched on and activated
- Switched on but deactivated
- Switched off
- Malfunction

3. Anti-lock brake system

For detailed information, refer to the brake support systems → page 131. The associated data element is the “anti-lock brake system status” in Class B, which may have the following status:

- Activated
- Deactivated
- Malfunction

4. Brake assist system (BAS)

For detailed information, refer to the brake support systems → page 131. The associated data element is the “brake assist system status” in Class B, which may have the following status:

- Switched on and activated
- Switched on but deactivated
- Switched off
- Malfunction

5. Electronic stability control (ESC)

For detailed information, refer to the brake support systems → page 131. The associated data element is the “electronic stability control status” in Class B, which may have the following status:

- Switched on and activated
- Switched on but deactivated
- Switched off
- Malfunction

6. Acceleration slip regulation (ASR)

For detailed information, refer to the brake support systems → page 131. The associated data element is the “traction control system status” in Class B, which may have the following status:

- Switched on and activated
- Switched on but deactivated
- Switched off
- Malfunction

Description of the recorded Class A data element

No.	Name	Description
1	Longitudinal delta-V	The variation of vehicle longitudinal speed. Longitudinal delta-V is only the longitudinal component of the total delta-V.
2	Maximum recorded longitudinal delta-V	Maximum longitudinal vehicle speed accumulation recorded by the EDR. This data should be used in conjunction with “Time to maximum delta-V, longitudinal”.
3	Time to reach maximum recorded longitudinal delta-V	The time taken from time zero to the maximum value of the cumulative change in speed, along the X-axis, as recorded by the EDR. This data should be used in conjunction with “Maximum recorded longitudinal delta-V”.
4	Clipping flag	Indicates the point at which the acceleration (lateral, longitudinal) collected by the EDR first reaches the sensor range.
5	Vehicle speed	The wheel speed or the vehicle speed obtained by other means. Data accuracy can be affected by factors such as significant deviations in tyre size compared to factory settings and wheel lock or wheel slip.
6	Service brake, on or off	Used to detect whether the driver has depressed the brake pedal.

No.	Name	Description
7	Driver's seat belt status	Status of the driver's seat belt buckle.
8	Accelerator position, percentage relative to full open position	The percentage of the actual position of the accelerator to the driver's fully depressed position.
9	Revolutions per minute (r/min)	The revolutions per minute of the engine's main crankshaft
10	Event power cycle count	The number of power cycles recorded in the ECU that captures EDR data since its initial use to the occurrence of the event. An example of a power cycle is when the ignition is switched from “off/assist” mode to “on/run” mode.
11	Event power cycle count at retrieval	The number of power cycles recorded in the ECU that captures EDR data since its initial use until the data retrieval. An example of a power cycle is when the ignition is switched from “off/assist” mode to “on/run” mode.
12	Event data recording complete status	Status flag of whether the event data is fully recorded and stored in the ECU that records the EDR data.
13	Time interval between this event and the last event	If two events occur within 5 seconds, the time is the elapsed time between the start of event X and the start of event X-1.
14	with vehicle identification number	The vehicle identification number (VIN) assigned by the vehicle manufacturer.
15	ECU hardware number for recording EDR data	The ECU hardware number in the vehicle that implements the EDR recording function. ▶

No.	Name	Description
16	ECU serial number for recording EDR data	The ECU serial number in the vehicle that implements the EDR recording function.
17	ECU software number for recording EDR data	The ECU software number in the vehicle that implements the EDR recording function.

Labels and plates

Vehicle safety certificates, labels, and plates containing important data and information are installed in the engine compartment and certain vehicle components.

- Do not remove or damage safety certificates, labels, and plates. Always keep the graphics and text on them legible.
- When replacing vehicle components with safety certificates, labels, or plates, the new parts should be installed with identical information by Volkswagen dealerships.

High voltage warning label

The high voltage warning label is located near the bonnet lock and displays a high voltage warning message for the vehicle's electrical system.

⚠ WARNING

Improper handling of the vehicle can easily lead to accidents and serious or fatal injuries.

- Always observe the relevant traffic regulations.
- Always follow the instructions in this manual.

ⓘ NOTICE

Improper handling and operation may damage the vehicle.

- Always comply with relevant regulations.
- Always follow the instructions in this manual.

Communication window on the windscreen

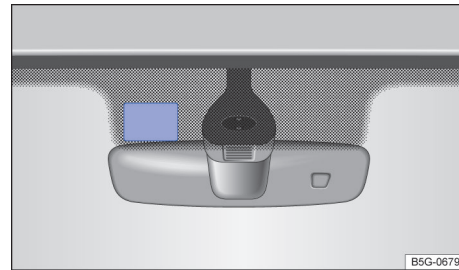

Fig. 160 Communication window on the windscreen (blue area) (illustration)

There is a communication window (blue area) located beside the interior mirror base on the windscreen. The communication window allows for the reception of electronic signals from external components.

You can securely insert a chip card into the communication window (blue area) beside the interior mirror base → Fig. 160.

Avoid covering the window area of the chip card or placing labels on the chip card. This may disrupt the reception of electronic signals and hinder the proper functioning of related electronic components.

Fluids in the air conditioning system

Refrigerant in the air conditioning system

The sticker in the engine compartment contains information regarding the type and quantity of refrigerant used in the vehicle's air conditioning system. The sticker is located at the front of the engine compartment, close to the refrigerant filler neck.

Symbols and descriptions:

- ⚠** Warning: the air conditioning system must always be serviced by trained specialists.
- ☼** Type of refrigerant.
- 🛢** Type of lubricating oil.
- 📖** See workshop information (available only for Volkswagen dealerships).



The air conditioning system must always be serviced by trained specialists.



Flammable refrigerant.



Make sure you dispose of all components correctly and never install components taken from older vehicles or recycling facilities into the vehicle.

Refrigerant oil in the air conditioning system

The air conditioning system is filled with a refrigerant oil. For the type and amount of refrigerant oil used, please consult the Volkswagen dealerships.

WARNING

To ensure safe and reliable operation, have the air conditioning system serviced only by suitably qualified personnel.

NOTICE

- Never have repairs on the evaporator carried out with replacement parts from end-of-life vehicles or from recycling.
- Never have replacements on the evaporator carried out with replacement parts from end-of-life vehicles or from recycling.

Radio reception and antenna

The original radio aerial of this vehicle may be installed in the following location inside the vehicle:

- Inner side of the rear window, fitted with the rear window heater.

The fine metal wire on the inner side of the window glass serves as the aerial.

NOTICE

Avoid using corrosive or acidic cleaning agents or any chemical materials to clean the windows or using hard objects to scratch the windows. This may damage the aerial on the window.

- Do not use tape or labels to secure the window-type aerial, for example the area of the rear window glass.
- Never use corrosive or acidic cleaning agents or other chemical materials to clean the aerial.

NOTICE

When adding a radio or navigation system, ensure compatibility between the vehicle's integrated aerial amplifier and the radio or navigation system installed. Alternatively, use an additional aerial adapter. Failure to do so may result in damage to the aerial amplifier due to overvoltage.



Using electrical devices near the window aerial may cause interference with the reception signal of the radio's AM band.

Electrical system component protection function

Some electronic components and control units are fitted with component protection as standard.

As a protection mechanism, the component protection in this vehicle has the following features:

- The component protection prevents the full operation of factory-supplied components when installed in other vehicles, e.g. after theft.
- Operation of components outside the vehicle is restricted.

Have the relevant electrical components installed or replaced by qualified workshops during vehicle maintenance. Volkswagen recommends using a Volkswagen dealership.

When the component protection is activated, information about the protected components will be displayed on the instrument cluster. Seek expert assistance from a Volkswagen dealership for professional testing.

Declaration of conformity

The corresponding manufacturer hereby declares that the components listed below were compliant with the basic requirements and any other relevant regulations and laws at the time the vehicle was produced.

Radio-based equipment

- Electronic engine anti-theft locking system.
- The vehicle key.
- Adaptive Cruise Control (ACC).
- Area monitoring system (Front Assist), including autonomous emergency braking function.
- Keyless locking and starting system Keyless Access.
- Pedestrian recognition.

Electrical devices

- 12-volt socket

Disposal of used batteries and electronic devices

Used batteries

Used batteries in vehicle keys, remote controls, and other electrical devices must be collected separately and recycled by the end user. This is indicated by the symbol  with the crossed-through waste bin.

- As the end user, you are required by law to return used batteries.

Batteries that contain heavy metals are marked with the chemical symbols Hg (mercury), Cd (cadmium) and/or Pb (lead). Heavy metals can damage the health of human beings and animals and can accumulate in the environment. To avoid this, please ensure that your used batteries are collected separately and returned properly.

- Further information on return and recycling can be obtained from your Volkswagen dealership.

Old electrical/electronic devices

Your vehicle contains electrical and electronic devices such as the SD card in the navigation system and remote controls. These devices are marked with a symbol  showing a crossed-through waste bin.

The corresponding legal regulations stipulate that old devices with this marking must be collected and disposed of separately from normal household waste. You can hand in these devices at local collection points or any nationally authorised return systems. Batteries or rechargeable

batteries that are not a fixed part of the device must be removed first and disposed of accordingly.

- You must delete all stored personal data before disposing of the old devices.
- Further information on return and recycling can be obtained from your Volkswagen dealership.



Batteries in vehicle keys and remote controls may contain perchlorate and should be subject to legal regulations for the disposal and scrapping of such batteries. Have such batteries replaced and disposed of by a suitably qualified workshop. Volkswagen recommends using a Volkswagen dealership.

Returning and scrapping end-of-life vehicles

Returning end-of-life vehicles

At the end of its life, your vehicle must be recycled and disposed of in an environmentally appropriate way. Volkswagen has formulated corresponding regulations for the recycling of end-of-life vehicles.

If you satisfy the national legal requirements, the vehicle return centre can return your end-of-life vehicle free of charge.

Further information on return and recycling can be obtained from your Volkswagen dealership.

Scrapping

The relevant safety requirements must be observed when scrapping the vehicle or its individual components, e.g. the airbag system and belt tensioners. These requirements are known to the correspondingly qualified workshops. Volkswagen recommends using a Volkswagen dealership. 

Technical data

Notes on technical data

All data in the official vehicle documents always takes precedence. Except where indicated or specifically stated, the technical data applies to the basic model without any additional equipment installed. The technical data may differ in the case of different model versions, special vehicles, and country-dependent equipment.

Drive form

The driving form of this vehicle is front-wheel drive.

Engine

The type and model of the engine are listed on the vehicle technical data label or vehicle registration document.

Description

Gearbox abbreviations: MG = manual gearbox, AG = automatic gearbox. MG5 stands for five-speed manual gearbox and AG6 stands for six-speed automatic gearbox.

⚠ WARNING

Strictly follow the specified technical data for this vehicle. Failure to adhere to the specified values for weight, payload, vehicle dimensions, and maximum speed in this manual may lead to accidents and cause serious or fatal injuries.

Data plate and engine number letter

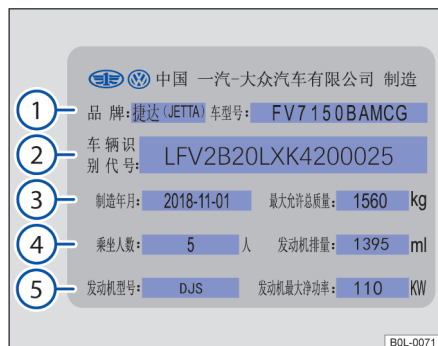

Fig. 161 Vehicle data plate (illustration)

Data plate

Type plate → Fig. 161 The data plate is affixed in the lower area of the door pillar on the front passenger side and contains the following data:

- 1 Trademark and model
- 2 Vehicle identification number (chassis number)
- 3 Date of manufacture and maximum allowable gross weight
- 4 Number of passengers and engine displacement
- 5 Engine model and maximum net engine power

Engine number letter

The engine model is recorded on the vehicle type plate → Fig. 161. In addition, the engine model is also stamped at the left side of the engine and gearbox junction.

ⓘ NOTICE

Depending on vehicle equipment, the engine number letters (MKB) can be displayed on the instrument cluster → page 13.

Vehicle identification number

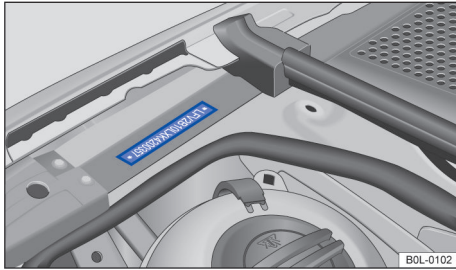

Fig. 162 In the engine compartment: vehicle identification number (illustration).



Fig. 163 In the windscreen: vehicle identification number.

Vehicle identification number in the engine compartment

The vehicle identification number is also stamped at the water drainage channel between the right suspension strut and the fender → Fig. 162.

Reading the vehicle identification number requires opening the bonnet → page 165, *Engine compartment*.

In addition, the vehicle identification number can be read through the viewer in the lower left corner of the windscreen → Fig. 163.

Depending on model, the vehicle identification number may also be stamped at other locations.

Reading the vehicle identification number via the diagnostic interface

The vehicle identification number is also stored in the Electronic Control Unit (ECU) and can be read using the corresponding diagnostic instrument.

The diagnostic interface is located in the footwell on the driver side underneath the dash panel.

Volkswagen dealerships are equipped with a special diagnostic instrument for Volkswagen models. Contact Volkswagen dealerships to read the vehicle identification number. Alternatively, if you wish to read the vehicle identification number yourself, you can purchase a special diagnostic instrument for Volkswagen models or a diagnostic instrument with a vehicle communication interface plug that complies with SAE J1962 standards and supports ISO 15765-4 and its associated standards.

Engine parameter

Engine

Engine output	Fuel injection technology	Engine code	Exhaust emission standard	Maximum torque	Number of cylinders, Displacement
110kW/ 5,000~6,000rpm	TSI®	DJS	China VI	250Nm/1,750~ 3,000rpm	4 cylinders 1,395ccm
		DLE			

NOTICE

Never use petrol with a lower octane number than the minimum indicated on the plate. This may cause damage to the engine.

Vehicle dimensions

The data in the table applies to the basic model with basic equipment.

The specified values can vary due to additional equipment, different model versions, and also for special vehicles and vehicles that have been manufactured for other countries.

Length	4,624 mm
Width	1,841 mm
Height (unladen weight)	1624/1633/1644 mm
Wheelbase	2,730 mm
Minimum turning diameter ^{a)}	10.8 m
Front wheelbase ^{a)}	1,572 mm
Rear wheelbase ^{a)}	1,544 mm
Ground clearance at allowable gross weight	160 mm

^{a)} The specified values can vary due to different wheel rim and tyre sizes.

! NOTICE

- Always drive carefully and be mindful of raised curbs or short posts in parking lots. These can easily damage the bumper and other vehicle parts when parking.
- Be cautious when encountering lane protrusions, ramps, curbs, and similar obstacles. Failure to do so may damage the bottom components of the vehicle, such as bumpers, spoilers, travel system, engine, and the exhaust system. <

Vehicle performance parameter

The values listed in the table below apply to vehicles with a properly run-in engine, driving under normal road and weather conditions.

The vehicle performance parameters provided in this manual are determined without any additional equipment that may affect the vehicle's performance, such as roof carriers or fenders.

Gradient angle

The gradient angle is an indication of the vehicle's gradeability and corresponds to the gradient that the vehicle can drive up under its own pow-

er. This depends on aspects such as the road surface, weather conditions and engine power. The values apply to a moving vehicle and not to driving off from standstill.

The number of metres in height gained over a distance of 100 m (gradient) will be given as a percentage or degree value (100% = 45 degrees). ►

Engine

Engine type	Gearbox type	Exhaust emission standard	Maximum speed	Vehicle gradient angle Maximum gradient angle of a single vehicle (%)
1.4L 110kW TSI® Petrol engine	MG5	China VI	180 km/h	30
1.4L 110kW TSI® Petrol engine	AG6	China VI	175 km/h	



Information on gradient angle:

- The different adhesion coefficient of different road surfaces will affect the vehicle's climbing ability and its gradient angle.
- The tyre pressure should match the values specified on the label inside the tank cap, and the tyre tread depth should be at least 90% of a new tyre.
- The vehicle's load distribution can impact its climbing performance, and it is important to evenly distribute the load between the front and rear axles.



Weights and axle loads

All data in the official vehicle documents always takes precedence. The data in this manual applies to the basic model with basic equipment. The type and model of the engine are listed on the model plate → Fig. 161 and in the technical data of the vehicle in the Maintenance Manual or in the vehicle registration document

The specified values can vary due to additional equipment, different model versions, and also for special vehicles.

The table below displays the vehicle's curb weight, which includes the dry weight of the vehicle along with various fluids and fuel (not less than 90% of the fuel tank capacity), spare wheel, and accessories. → ⚠. The dry weight refers to

the complete vehicle's weight, including the body, all electrical components, and necessary equipment for normal operation.

The payload of the vehicle is calculated as the rated total weight minus the curb weight.

Therefore, installing or modifying equipment and accessories will increase the curb weight and reduce the vehicle's payload accordingly.

The vehicle's payload consists of the following weights:

- Occupants.
- Cargo and any loaded items.
- Roof load, including roof carrier system.

Engine output	Gearbox type	Exhaust emission standard	Curb weight	Vehicle rated gross weight	Front axle allowable load	Rear axle allowable load
1.4L 110kW TSI® Petrol engine	MG5	China VI	1,390 kg	1,850 kg	920 kg	930 kg
1.4L 110kW TSI® Petrol engine	AG6	China VI	1,425 kg	1,880 kg	955 kg	925 kg



⚠ WARNING

Do not exceed the vehicle's maximum weight and axle load when loading objects. This may cause damage to the vehicle and result in accidents and serious or fatal injuries.

- Ensure that the actual axle load stays within the specified limit.

- Please note that the vehicle's handling and braking performance are affected by the load and its distribution. Adjust your driving speed accordingly.

ⓘ NOTICE

Distribute the loaded objects evenly inside the vehicle. When carrying heavy objects in the luggage compartment, position them near the rear axle or above it to minimize any impact on vehicle stability. <

Seat position and backrest angle

The seat position for measuring seat cushion depth is the design position, and the backrest angle is set to the design angle. The specific adjustment methods are as follows:

Front seats

Adjust the seat to the design position

- Adjust the front seats to their rearmost and lowest positions → page 65.
- Move the driver seat backrest forwards 50mm;
- Move the front passenger seat backrest forwards 40mm;
- Raise the seats by 41.4mm from the lowest position.

Adjust the backrest angle to the design angle

- Adjust the headrest of the front seats to the highest position → page 65.
- Set the backrest angle to align the headrest guide rod with a vertical line at a 13° angle.

Rear seats

Seat design position and backrest design angle

- The loaded position of the rear seat cushion corresponds to the design position.
- The backrest angle is set at the design angle when it is in the locked position. <

Four-wheel alignment parameters

Testing conditions

- Ensure that the vehicle suspension, wheel bearing assemblies, steering system, and steering linkage system are free from out-of-tolerance, looseness, and damage → ⚠.
- The tread depth difference between two tyres on the same axle should not exceed 2mm.
- The tyre pressure is as specified.
- The vehicle is unloaded.
- The fuel tank must be full.
- Ensure the spare wheel and vehicle toolkit are located in the correct position.

- The windscreen washer fluid reservoir must be filled.
- When inspecting wheel alignment, avoid extreme positions of movable bases and turntables.

Cautions for wheel alignment inspection

- The equipment must be installed and calibrated according to the specifications, and operations should strictly adhere to the instructions provided by the manufacturer.

Seek guidance from the wheel alignment tool/computer manufacturer if necessary.

Over time, the wheel alignment platform and tool/computer may require recalibration. ▶

Regularly inspect and adjust the wheel alignment platform and tool/computer at least once a year as part of equipment maintenance.

Four-wheel alignment parameters

Vehicle model		1.4L 110kW TSI® Petrol engine
Front wheel	Wheel camber	-16'±30'
	Caster angle (non-adjustable)	7°09'±30'
	Front toe	10'±10'
Rear wheel	Wheel camber	-1°20'±30'
	Rear toe	25'±10'

WARNING

Incorrect repairs and modifications to the vehicle can cause breakdowns, damage the vehicle, reduce the efficiency of the steering wheel and braking system. This can cause malfunctions and lead to accidents and serious or fatal injuries.

- The maintenance and modification of the vehicles shall be carried out by the qualified workshop who have the necessary tools, diagnostic instruments, maintenance materials and qualified professional and technical personnel.

WARNING

- Only approved four-wheel alignment equipment should be used for alignment purposes.
- Volkswagen dealerships have access to approved four-wheel alignment equipment and have been trained accordingly. Therefore, have the vehicle four-wheel alignment performed at a qualified workshop. Volkswagen recommends using a Volkswagen dealership.
- Four-wheel alignment values beyond the above parameters will seriously affect the driving stability of the vehicle. Any damages or malfunctions resulting from unauthorized alignment adjustments are not covered under the warranty.

Brake system related data

Brake pedal's free stroke

The free stroke of the brake pedal is the displacement of the brake pedal before the brake master cylinder starts to build pressure.

The free stroke of the brake pedal should be consistent with the technical requirements of the vehicle.

The reasonable range of free stroke of brake pedal is 3-10 mm.

Brake friction wear limit

Brake type	Brake friction wear limit
Front disc brake (15" APG57)	Brake pad: Residual thickness of friction material is 2 mm (excluding bottom plate)
	Brake disc: disc thickness worn to 21 mm
Rear disc brake (15" FNC-M38)	Brake pad: Residual thickness of friction material is 2 mm (excluding bottom plate)
	Brake disc: disc thickness worn to 8 mm

⚠ WARNING

Incorrectly performed repairs and modifications on the vehicle, e.g. through use of unsuitable parts, can damage the vehicle and cause accidents and serious or fatal injuries!

- The maintenance and modification of the vehicles shall be carried out by the qualified workshop who have the necessary tools, diagnostic instruments, maintenance materials and qualified professional and technical personnel.

Wheel and tyre related data

Driving wheels

Tyre specification	Wheel specification
225/55 R17 97H	7J×17 ET45
225/50 R18 95H	7J×18 ET45

Spare wheel

Tyre specification	Wheel specification
T125/70 R18 99M	3.5Jx18 H2 ET25.5

Tank capacities

Tank capacity
Approx. 51 L, of which about 8 L reserve.

Fuel consumption rate and CO₂ emission

The fuel consumption rates listed in this specification are determined on the basis of vehicle re-conditioning weight in accordance with the following working conditions specified in GB/T19233-2020 and GB/ T12545.1-2008 standards.



The fuel consumption and emission rates listed in this manual are not specific to any particular vehicle type. The fuel consumption and CO₂ emission rates are not only dependent on the performance of the vehicle, but also closely related to your driving style and other non-technical factors (e.g., road conditions, altitude, traffic flow and weather conditions).

Vehicle fuel consumption not only depends on fuel efficiency, but also on non-technical factors such as driving performance and environmental conditions. Add-up parts, tyres and other auxiliary equipment and accessories can change the weight, rolling resistance, aerodynamics and other important vehicle parameters, which are in addition to weather and traffic conditions, affect fuel consumption and power. Therefore, fuel consumption during daily driving may be different from the fuel consumption values listed in the table below.

Vehicle model	Engine type	Fuel consumption as measured by GB/T19233-2020 and GB/ T12545.1-2008 standards.			Comprehensive emission of WLTC_CO ₂
		Constant fuel consumption of 90 km/h	Constant fuel consumption of 120 km/h	WLTC fuel consumption	
FV6460LAACG	1.4L 110kW TSI [®] Petrol engine	5.2 l	7.6 l	7.34 l/100 km	174.00 g/km
FV6460LAMCG	1.4L 110kW TSI [®] Petrol engine	5.7 l	8.0 l	6.54 l/100 km	155.00 g/km

Vehicle model	Engine type	Fuel consumption as measured by GB/T19233-2020 and GB/ T12545.1-2008 standards.			Comprehensive emission of WLTC_CO ₂
		Constant fuel consumption of 90 km/h	Constant fuel consumption of 120 km/h	WLTC fuel consumption	
FV6460LA-MEG	1.4L 110kW TSI [®] Petrol engine	5.7 l	8.0 l	6.62 l/100 km	156.89 g/km
FV6460LAAEG	1.4L 110kW TSI [®] Petrol engine	5.2 l	7.6 l	7.09 l/100 km	168.03 g/km

 Actual fuel consumption may be slightly different from that listed in this specification.

 The fuel consumption rate and CO₂ emission rate may increase slightly due to the change of vehicle assembly weight with different vehicle configurations and the addition of accessories. 

Abbreviations

Abbreviation	Definition
A	Amp rating, unit of measurement for current strength
A2DP	Advanced Audio Distribution Profile: manufacturer-independent technology for audio signal transmission via Bluetooth®.
ABS	Anti-lock brake system
ACC	Adaptive cruise control
AG6	6-speed automatic gearbox
AM	Medium wave (amplitude modulation)
App	Application
ASR	Acceleration slip regulation
AUX	Auxiliary Input
AVRCP	Audio Video Remote Control Profile: manufacturer-independent technology for remote control of audio sources via Bluetooth®.
BAS	Brake support systems
CAS	Conditional Access System
ccm	Cubic centimetre, engine displacement measurement unit
CO ₂	Carbon dioxide
DAB	Digital transmission standard for digital audio broadcasting
DLC	Data connection port
DWA	Anti-theft alarm system
E90	Ethanol gasoline
EDS	Electronic differential lock
EPC	Electronic power control
ESC	Electronic stability control
ETC	Electronic toll collection system
FAQ	Frequently asked questions
FM	Ultrashort wave, UKW (frequency modulation)
g/km	Vehicle carbon dioxide emissions per kilometre (in grams)
GALA	Volume automatically adjustment with speed
GPS	Global positioning system
GRA	Cruise control system
GSM	Global system for mobile communications
HFP	Wireless telephone (Hands-free profile)
ISO	International organization for standardization
IT	Information technology
kN	Kilonewtons, unit of force
kPa	Kilopascal, a unit of Tyre pressure
kW	Kilowatt, a measure of engine output
LED	Light emitting diode



Abbreviation **Definition**

LRP	Leaded replacement petrol
MFD	Multifunctional display
MG5	5-speed manual gearbox
MKB	Engine number letter
MP3	Format for compressing audio files
MPEG	Moving picture experts group
N	Newton, unit of force
Nm	Newton meter, unit of torque
OBD	On-board diagnostic system
RON	Research octane number: indication of the knock resistance of petrol.
rpm	Revolutions per minute - engine speed
rSAP	Bluetooth [®] remote SIM card access profile (remote SIM-Access-Profile)
SD	Secure digital (memory card)
SIM	Subscriber identity module
SMS	Short message service
SRE	Sequential fuel injection
SSID	Wi-Fi network name
TC	Traction control
TIN	Tyre identification number
Trip	Trip odometer
TSI [®]	Direct injection supercharged petrol engine
TWI	Trade wear indicator
UMTS	Universal mobile telecommunications system
USB	Universal serial bus
V	Volt, unit of voltage measurement
VIN	with vehicle identification number
Wi-Fi	WLAN: Wireless local area network
WMA	Format for compressing audio files
XDL	Extension of the electronic differential lock